

UltraGold™ Infrared Right Size Fryer

IR-RS-20x14-UCP with UltraClear™ Plus Filtration

The UltraGold™ Right Size series is designed to meet your high-volume needs while ensuring energy efficiency. Unlike competitor fryers that only hold two fry baskets per vat, the RS holds three baskets per vat, so you can cook more food. You'll save on oil as well — two right size fryers will easily replace three traditional 50 pound fryers saving up to 15% in oil per refill.

Our UltraClear Plus filtration system, which has all internal plumbing and pumps, cleans shortening to increase food quality and extend oil life.

Like our other UltraGold™ fryers, the RS series can be expanded to up to four vats to increase production.

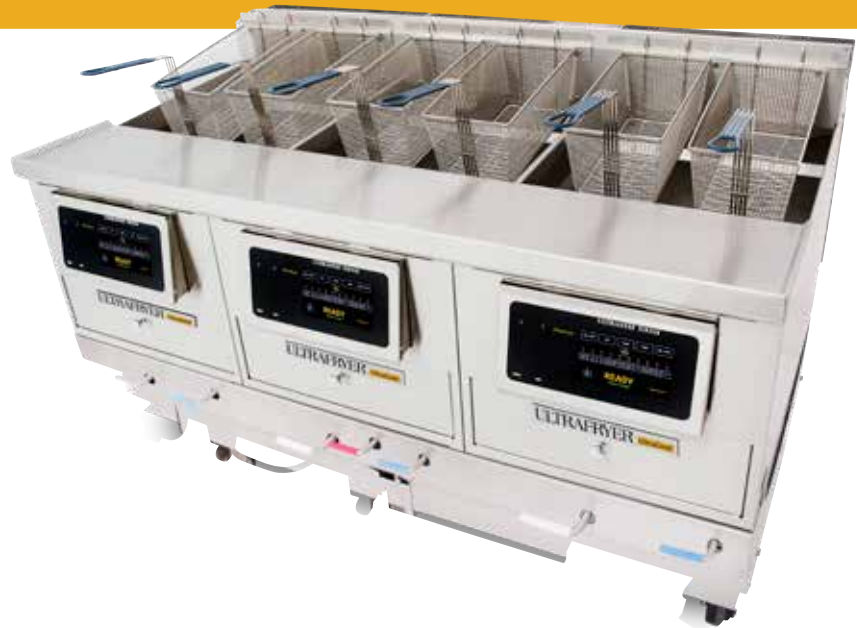

STANDARD FEATURES

- Energy Star® rated
- Thermostat Controller
- Dual Infrared burners with phased-array heat exchangers
- Two vats
- UltraClear™ Plus filtration
- Six fast-flow filter envelopes
- Total stainless steel construction
- Heavy-duty casters
- Electronic ignition
- Baskets (2 ea. 16.37"L x 8"W x 6.75"D or 3 each 16 3/8" L x 5" W x 5 1/4" D)
- Shortening disposal valve

OPTIONS

- UltraStat® 402 touchscreen computer controls
- UltraStat® 23 computer controls
- UltraGuard™ automatic melt cycle with vat protection
- UltraSense™ dual oil sensing technology
- Up to four vats
- Wash wand hose

- Continuous drain board
- Tub scraper and cleaning brush
- 20 x 14" stainless steel shake zone vat

ACCESSORIES

- Vat covers
- Splash guards
- Heat tape
- Fast-flow filtration pads
- Stainless steel filter screen
- Drain valve for filter tub
- Boil out hose
- Fast-flow filtration pads
- Shortening disposal line
- Gas line with restraining cable
- Shortening shuttle

Project _____

Item _____

Quality _____

Approval _____

Date _____



Ultrafryer®

UltraGold™ Infrared Right Size Fryer

IR-RS-20x14-UCP with UltraClear™ Plus Filtration

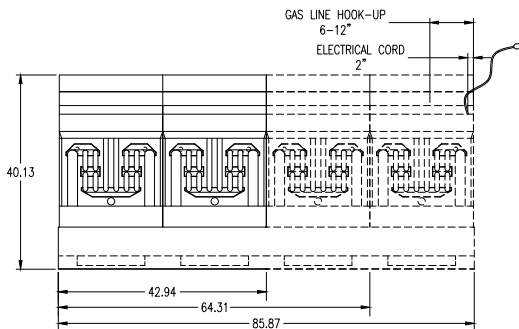

TOP VIEW

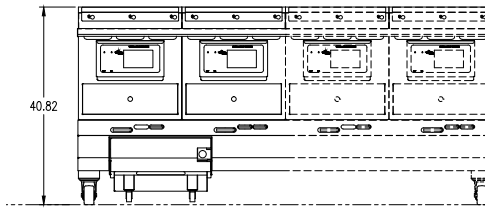

FRONT VIEW

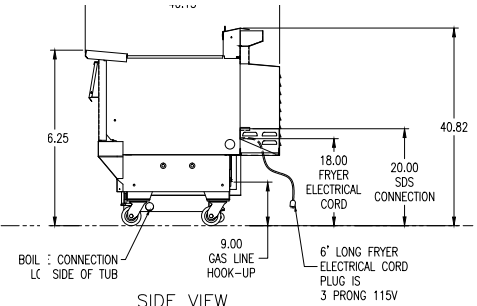

SIDE VIEW

Sales ID#	Oil Capacity	Overall Size (H x D x W)	Nominal Vat Size	Total BTUH	Net Weight	Shipping Info
IRRS-20x14-2-UCP	65 lbs per vat	40.82" x 40.13 x 42.94" (1036 x 1085 x 1095 mm)	20" x 14" (508 x 356 mm)	240,000	590 lbs (257.6 kg)	F.O.B. Factory San Antonio, TX
IRRS-20x14-3-UCP	65 lbs per vat	40.82" x 40.13" x 64.31" (1036 x 1085 x 1633 mm)	20" x 14" (508 x 356 mm)	360,000	810 lbs (353.8 kg)	F.O.B. Factory San Antonio, TX
IRRS-20x14-4-UCP	65 lbs per vat	40.82" x 40.13" x 85.87" (1036 x 1085 x 2181 mm)	20" x 14" (508 x 356 mm)	480,000	987 lbs (442.3 kg)	F.O.B. Factory San Antonio, TX

Performance determined in accordance with ASTM F1361-91 Standard Test Method for the performance of open vat fryers. Energy input rating 120,000 BTU's/hr

CONTROL ELECTRICAL REQUIREMENTS

Controller 120V, 60 HZ, 1 Phase, 1.2 amps ea. vat + 3.1 amps with pump
Electrical cord is 6' long and located on RH side in rear. (control circuit)

GAS SPECIFICATIONS

Gas	Gas Line 2 Vat	Gas Line 3-4 Vat
7" water column NG	3/4"	1-1/4"
14" water column LP	3/4"	1-1/4"

HEAT EXCHANGER & VAT CONFIGURATION

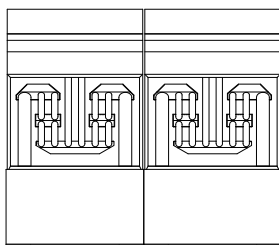

Dual Phased Array Heat Exchangers with IR Burners

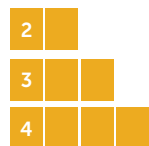

2 to 4 vats

FILTER SYSTEM

UltraClear Plus Filtration



© 2017 Ultrafryer Systems, Inc. Due to continuing engineering development and improvements, specifications are subject to change without notice.

Revision date: 1.30.2019

Ultrafryer®