

Ultrafryer OneTouch™ 20 Series

P5-20-OT with OneTouch Filtration

Our new OneTouch fryer is designed to be operated easily and safely. This fryer features our UltraStat 402 touchscreen controls can be programmed with up ten menu items and is WiFi ready.

The OneTouch Filtration system cleans your oil quickly and is 100% automatic, just press a button.

The 20" vat is perfect for high production restaurants. If you need more production, simply add up to six vats for the ultimate frying battery.

The UltraGuard™ automatic melt cycle brings shortening to temperature without scorching or overheating. It also detects oil levels to guard against dry firing.

Give the new OneTouch a fry and take your frying program to the next level.



STANDARD FEATURES

- Energy Star® rated
- UltraStat™ 402 touchscreen controls
- UltraGuard™ automatic melt cycle with vat protection
- PAR-5 phased-array heat exchanger
- 80,000 BTUH per vat
- Three vats
- OneTouch filtration
- 6 fast-flow filter envelopes
- Total stainless steel construction
- Heavy-duty casters
- Electronic ignition

- Baskets (2 ea. 16.37" L x 8"W x 6.75"D or 3 each 16 3/8" L x 5" W x 5 1/4" D)

ACCESSORIES

- Vat covers
- Splash guards
- Fast-flow filtration pads
- Stainless steel filter screen
- Drain valve for filter tub
- Boil out hose
- Fast-flow filtration pads
- Shortening disposal line
- Gas line with restraining cable

Project _____

Item _____

Quality _____

Approval _____

Date _____

OPTIONS

- Add up to a total of six vats



Ultrafryer®

Ultrafryer OneTouch™ 20 Series

P5-20-OT with OneTouch Filtration

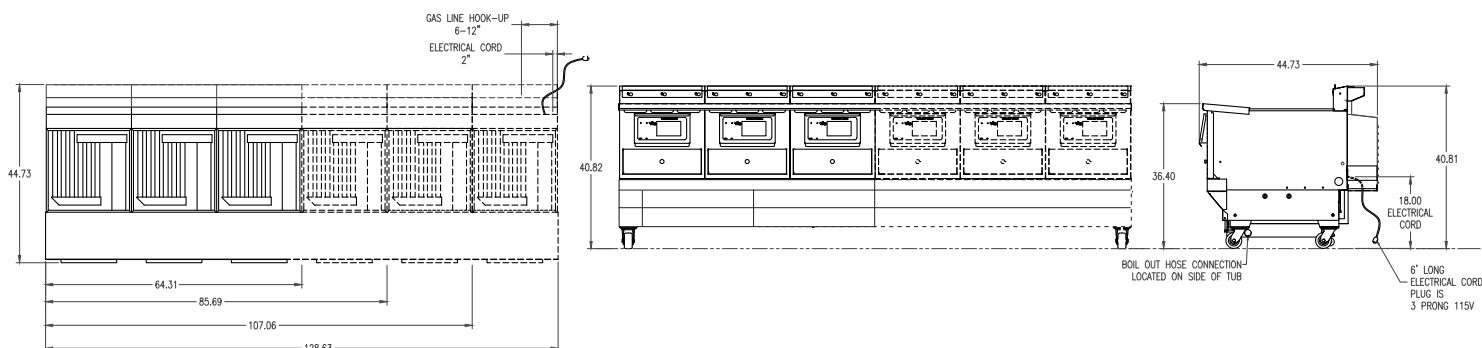

Sales ID#	Oil Capacity	Overall Size (H x D x W)	Nominal Vat Size	Total BTUH	Net Weight	Shipping Info
P5-20-3-OT	125 lbs (63.7 liters) per vat	40.81" x 44.73" x 64.31" (1,036 x 1,136 x 1,633 mm)	20" x 20" (508 x 508mm)	240,000	810 lbs (388.2 kgs)	F.O.B. Factory San Antonio, TX
P5-20-4-OT	125 lbs (63.7 liters) per vat	40.81" x 44.73" x 85.69" (1,036 x 1,136 x 2,177 mm)	20" x 20" (508 x 508mm)	320,000	987 lbs (446.3 kgs)	F.O.B. Factory San Antonio, Texas
P5-20-5-OT	125 lbs (63.7 liters) per vat	40.81" x 44.73" x 107.06" (1,036 x 1,136 x 2,719 mm)	20" x 20" (508 x 508mm)	400,000	1,267 lbs (575.5 kgs)	F.O.B. Factory San Antonio, Texas
P5-20-6-OT	125 lbs (63.7 liters) per vat	40.81" x 44.73" x 128.63" (1,036 x 1,136 x 3,267 mm)	20" x 20" (508 x 508mm)	480,000	1,400 lbs (636.4 kgs)	F.O.B. Factory San Antonio, Texas

CONTROL ELECTRICAL REQUIREMENTS

Controller 120V, 60 HZ, 1 Phase, 1.2 amps ea. vat + 3.1 amps with pump
Electrical cord is 6' long and located on RH side in rear. (control circuit)

GAS SPECIFICATIONS

Gas	Gas Line 2-3 Vat	Gas Line 4 Vat	Gas Line 5-6 Vat
7" water column NG	3/4"	1"	1-1/4"
14" water column LP			

HEAT EXCHANGER & VAT CONFIGURATION

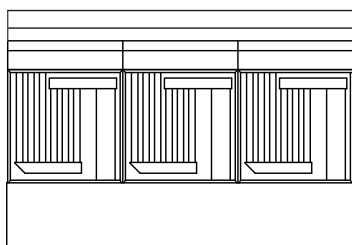

PAR-5 Phased Array Heat Exchanger

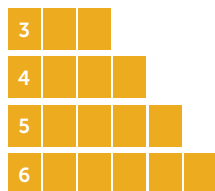

3 to 6 vats

FILTER SYSTEM

OneTouch Filtration 100% Automatic



© 2017 Ultrafryer Systems, Inc. Due to continuing engineering development and improvements, specifications are subject to change without notice.

Revision date: 1.30.2019

Ultrafryer®