

UltraPro™ 14

B-IRS-14-UC with UltraClear Filtration

The UltraPro 14 is a powerful gas fryer in a compact footprint.

This model has a single, 14 in. vat with a 45 lb. oil capacity. It features Our UltraClear™ filtration system, which cleans shortening to increase food quality and extend oil life.

Our patented PAR-3 phased-array heat exchanger is perfect for menu items that require higher heat and faster cooking times. It's designed to direct heat through multiple baffles and turns, resulting in highly efficient transfer of energy to the oil and more even heat distribution, virtually eliminating recovery times. This system is powered by a zero-maintenance infrared burner that does not need to be replaced.

The UltraGuard™ automatic melt cycle brings shortening to temperature without scorching or overheating. Our UltraSense™ oil management system automatically indicates whether oil is ready to use or needs filtering or changing. It also detects oil levels to guard against dry firing.

Intuitive touchscreen controls are so easy to use, new employees can be trained in minutes.

Project _____

Item _____

Quality _____

Approval _____

Date _____

STANDARD FEATURES

- Energy Star® rated
- Infrared burner
- PAR-3 phased-array heat exchanger
- UltraClear™ filtration system
- UltraSense™ dual oil management
- UltraStat® 402 touchscreen controls
- UltraGuard™ automatic melt cycle with vat protection
- Stainless steel construction
- One vat
- Heavy-duty casters
- Two fry baskets per vat (each 12.25" L x 5.8" W x 6.75" D)
- Six fast-flow filter envelopes
- Input power 90,000 BTUH

OPTIONS

- Add up to five vats

ACCESSORIES

- Vat covers
- Splash guards
- Fast-flow filter pads
- 3/4" gas line



Ultrafryer®

UltraPro™ 14

B-IRS-14-UC with UltraClear Filtration

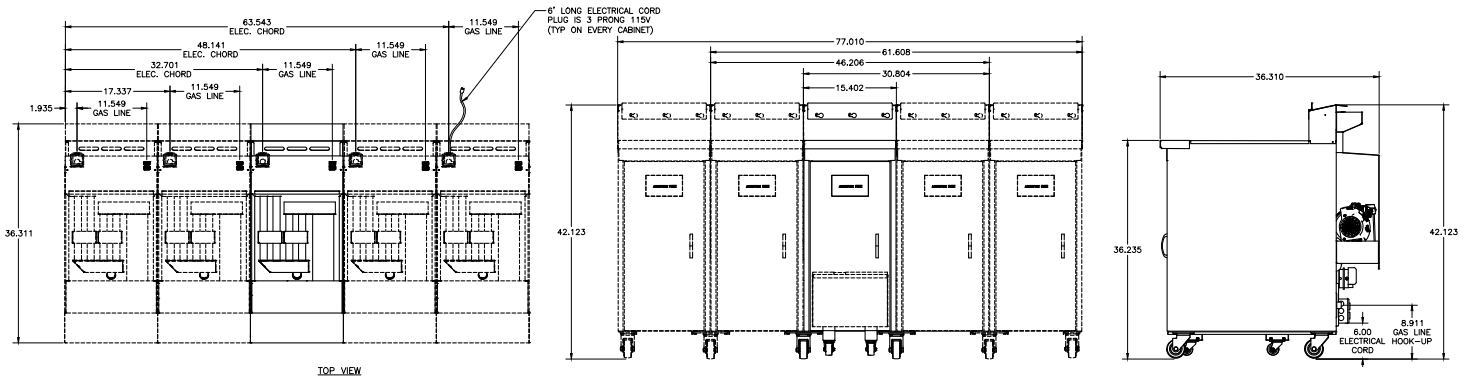

Sales ID#	Oil Capacity	Overall Size (H x D x W)	Gas Inlet	Net Weight	Shipping Info
B-IRS-14-UC	45 lb (22 liters) per vat	42.12" x 36.31" x 15.4" (1070 x 922 x 391 mm)	7" water column natural gas 14" water column propane	150 lb (68 kg)	F.O.B. Factory San Antonio, Texas

Performance determined in accordance with ASTM F2144 Standard Test Method for the performance of large open vat fryers.

ELECTRICAL REQUIREMENTS

120 V, 60 Hz, 1 phase,
8.5 A

Cord is 6' and located on
rear left-hand side.

PERFORMANCE SPECIFICATIONS

Nominal vat size: 14" (356
mm x 356 mm)

Energy input rate: 90,000
BTU/hr (95 megajoules)

Shortening capacity: 45
lb (22 L)

FILTER

UltraClear triple filtration



ULTRASENSE™

Dual oil-sensing
technology



CONTROLS

UltraStat® 402 touchscreen
controls



HEAT EXCHANGER & VAT CONFIGURATION

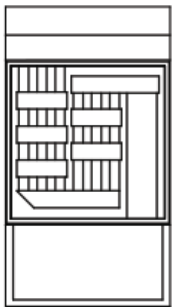

PAR-3 Phased Array
Heat exchanger



Infrared Burner

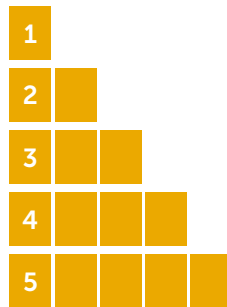

Up to 5 vats

GAS REQUIREMENTS

3/4" gas line is required to operate fryer (not included).

© 2017 Ultrafryer Systems, Inc. Due to continuing engineering development and improvements, specifications are subject to change without notice.

Revision date: 1.30.2019

Ultrafryer®