

Free Standing Model

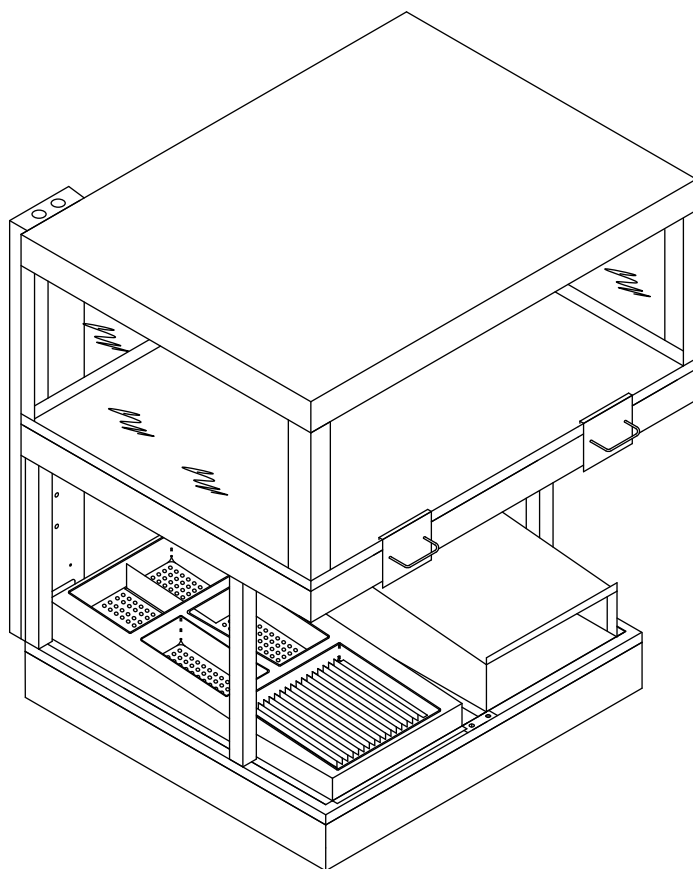

CounterTop Model

40 INCH WORK STATION

Assembly Instructions



302 Spencer Lane • P.O. Box 5369 • San Antonio, Texas 78201

(800) 525-8130 - Fax: (210) 731-5099 - www.ultrafryer.com

30A147

PREFACE

This Manual was written and published by the Engineering Department, Ultrafryer Systems for use by equipment installers who will install a 40" (1016mm) wide CounterTop or Free Standing Work Station in a commercial cooking environment.

**ENGINEERING DEPARTMENT
ULTRAFRYER SYSTEMS
302 SPENCER LANE
SAN ANTONIO, TX 78201**

TABLE OF CONTENTS

GENERAL INFORMATION	PAGE
Warranty	2
Safety	3
Description / Specifications	3
 UNPACKING, INSTALLATION, CLEANING AND SIDE ITEM WARMER DUMP PAN INSERTS	
Unpacking	5
Installation	6-9
Cleaning	9
Side Item Dump Pan Inserts	10-12
 FREE STANDING MODEL OPTIONAL ACCESSORIES	
General	13
Built-In Model 100TD Full Size Food Warmer	13
Disher Well Sink and Water Faucet	13
Okra Dump Pan and Inserts	14-15
Storage Cabinet	15
 SERVICE AND PARTS	
Technical Assistance	14
Ordering Information	14
Parts Identification	15-16
 WIRING LADDER DIAGRAM	 18

GENERAL INFORMATION

A. WARRANTY

ULTRAFRYER SYSTEMS ASSOCIATED EQUIPMENT WARRANTY

Ultrafryer Systems warrants to the original purchaser of the BATTER/SIFTER CART, CHUB WARMER, PRODUCTION COUNTERS, and EXPEDITE STATIONS sold within the United States, its territories and Canada, that it will be free of defects in material and workmanship for the period listed below:

PARTS WARRANTY – Parts are covered for a period of one (1) year from the initial start up date. Ultrafryer Systems reserves the right to charge for certain parts that exceed the price of \$100.00 until the defective part is returned to Ultrafryer. After inspection, and a determination is made that the defect is not the result of neglect or abuse a credit will be issued to the equipment owner's account. All parts are to be shipped back to Ultrafryer Systems, **ATTN: WARRANTY DEPARTMENT**, and **prepaid by the customer**.

QUARTZ LAMPS – The **QUARTZ LAMPS** that are supplied with **WARMERS** are **NOT** under any warranty with Ultrafryer Systems.

PROCESSING WARRANTY CLAIMS – The equipment owner must promptly notify Ultrafryer Systems Warranty Department of any alleged defects as soon as discovered by calling 800-525-8130. After such notice, the Warranty Department will perform its obligation under this warranty within a commercially reasonable period of time. If alleged defects develop after normal business hours, on weekends, or holidays the owner must call Ultrafryer Systems first at the above number. This number is monitored 24 hours a day and 7 days a week. Ultrafryer Systems will notify an **AUTHORIZED** service agent to make repairs during normal hours and, if necessary, after normal working hours. Any repairs done **without AUTHORIZATION from Ultrafryer Systems** on equipment under the warranty is subject to non-payment by Ultrafryer Systems.

NON WARRANTY COVERAGE – This warranty does not include coverage for any consequential cost of damages including, but not limited to, any loss in store sales, spoiled food products, transportation, duty or custom cost. This does not cover original installation and adjustments such as leveling, calibrations, and electrical connections. This warranty does not cover travel over 100 miles or 2 hours drive time from the location of the BATTER/SIFTER CART, CHUB WARMER, PRODUCTION COUNTER, and EXPEDITE STATION, or overtime, or unauthorized repairs or installation, damage in shipment, and normal maintenance. This warranty does not cover any other equipment that may be supplied to the PRODUCTION COUNTER, or EXPIDITE STATION. If **a dealer supplies any accessories to the Ultrafryer Systems PRODUCTION COUNTER or EXPEDITE STATION, the owner must notify the dealer** of any defects for repair or supply of any parts. **Ultrafryer Systems reserves the right to void any component part warranty on the BATTER/SIFTER CART, CHUB WARMER, PRODUCTION COUNTER, and EXPEDITE STATION that is stored for more than 6 (six) months after shipment from Ultrafryer Systems and not put into service.**

LABOR COVERAGE – The cost for labor to replace parts or service the BATTER/SIFTER CART, CHUB WARMER, PRODUCTION COUNTER, and EXPEDITE STATION is covered for a period of one (1) year from the initial start up date. The warranty department must be promptly notified of any defects within the first year of operation. An **AUTHORIZED** service agent of Ultrafryer Systems will cover labor for repairs and service.

DISCLAIMER OF WARRANTIES

Other than as stated herein Ultrafryer Systems makes no warranty of any kind, express or implied, including but not limited to any warranty of merchantability of fitness for a particular purpose, including trade usage. Ultrafryer Systems sole obligation, and purchaser's sole remedy, under this warranty is repair or replacement, at the discretion of Ultrafryer Systems, of any part or component that proves to be defective in materials or workmanship. In no event shall Ultrafryer Systems be liable for consequential, incidental, or special loss or damages arising from the use of, or inability to use, the BATTER/SIFTER CART, CHUB WARMER, PRODUCTION COUNTER, and EXPEDITE STATION. There are no other documents or oral statements for which Ultrafryer Systems will be responsible.

B. GENERAL

SAFETY: The major safety concern associated with the Free Standing or CounterTop Work Station is burns from **HOT** Product Containers, Biscuit Warmers and Quartz Warmer Lamps in the Chicken and Side Item Warmers. Both Work Stations operate on 120 VAC, single (1 Ø) Phase, electrical power. **NO** repair to electrical components should ever be attempted without first disconnecting **ALL** electrical power, **FAILURE** to do so could result in serious electrical shock or death.

C. DESCRIPTION

DESCRIPTION - Both Work Station Models were designed by Ultrafryer Systems to operate as a **CENTRAL SERVICE AREA** to expedite filling Customer Orders. They are constructed from 16, 18 and 20 gauge, type 304 stainless steel with a #3 finish. The 40" (1016mm) Work Station has the capacity for holding and warming eight (8) product pans beneath the Chicken/Side Item Warmers. Both Work Stations are equipped with a Biscuit Warmer Holder and a Side Item Dump pan. Some Work Stations may substitute a Wells Food Service Company Model 100TD built-in Food Warmer in place of the Biscuit Warmer Holder which would increase the possible holding and warming capacity to twelve (12) pans depending on the size of the product pans. Either Work Station can be provided as a LEFT hand or a RIGHT hand version based on the operating location.

NOTE: WIRE CHASE PLACEMENT DEPENDENT ON LH OR RH VERSION.

D. SPECIFICATIONS

(Left Hand Version Shown)

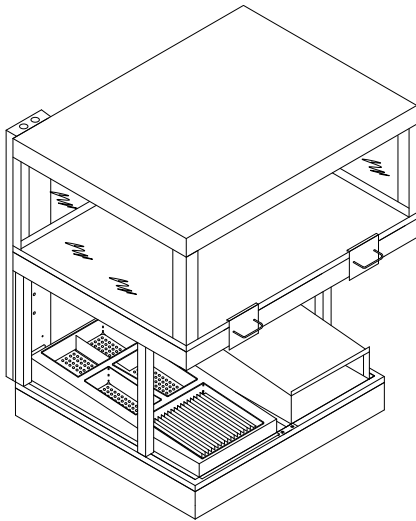

COUNTERTOP WORK STATION

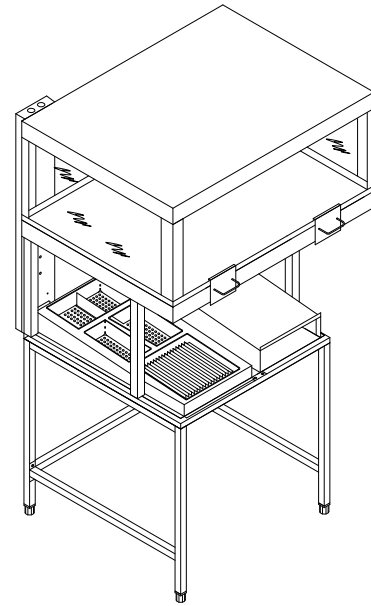

FREE STANDING WORK STATION

E. DIMENSIONS

	<u>Free Standing</u>	<u>CounterTop</u>
Width	40" (1016mm)	40" (1016mm)
Depth	31" (787mm)	31" (787mm)
Height	75 ¼" (1911mm)	43 ¼" (1099mm)

Electrical Requirements 120 VAC 60 Hz 1 Ø 30 Amps

NOTE: If a Built-in Food Warmer is used in lieu of a Biscuit Warmer Holder, the ampere requirement increases to 40.

**UNPACKING, INSTALLATION, CLEANING AND
SIDE ITEM DUMP PAN INSERTS**

A. UNPACKING

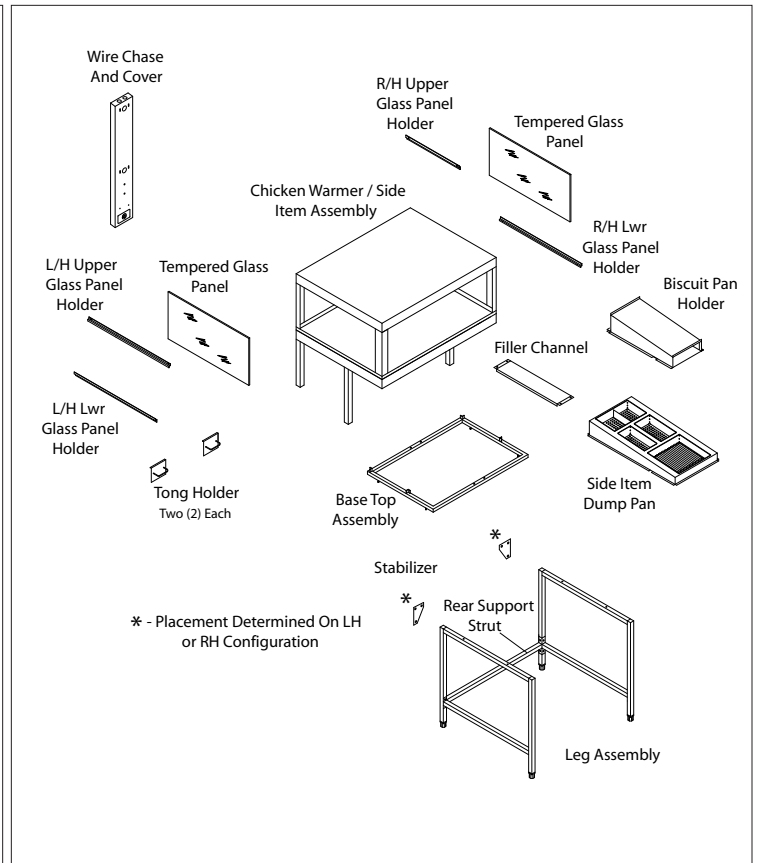
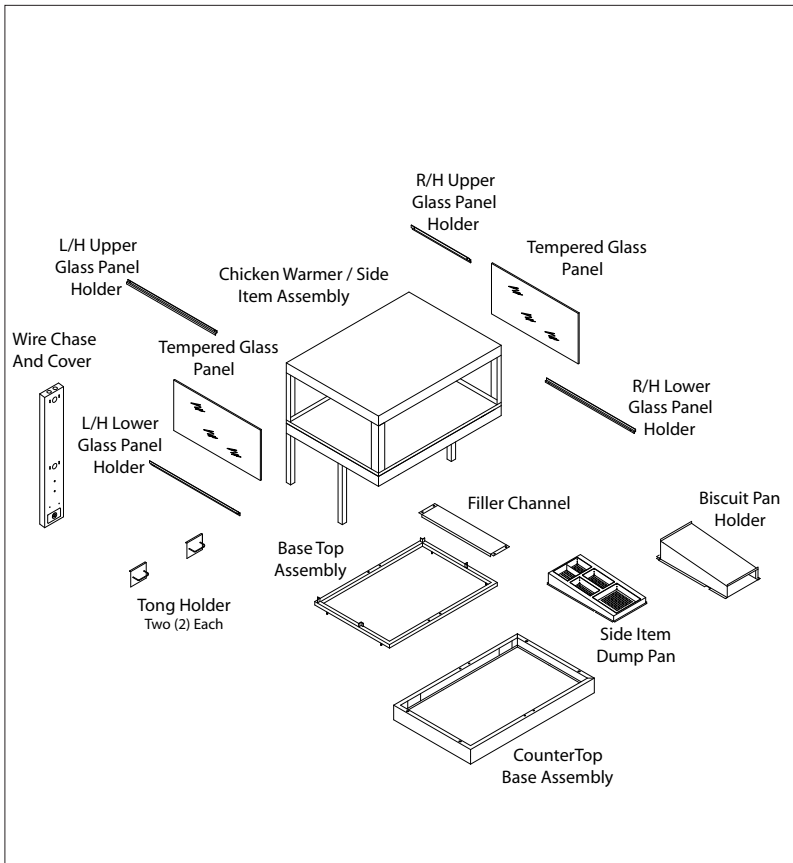

CounterTop Model

Free Standing Model

1. **CAREFULLY** remove the packing material from the Work Station and **THOROUGHLY** check each item for visible damage. If damage is found **DO NOT** refuse shipment, but contact the carrier and file the appropriate freight claims.
2. Unwrap, remove, and temporarily set aside all parts and accessories packed in cartons.
3. Place the following **MAJOR** components in separate areas to facilitate assembly of the Work Station:
 - a. CounterTop Model
 - 1) **BASE TOP ASSEMBLY, FILLER CHANNEL AND COUNTERTOP BASE ASSEMBLY**
 - 2) **CHICKEN/SIDE ITEM WARMERS, BISCUIT PAN HOLDER AND SIDE ITEM DUMP PAN ASSEMBLY**
 - 3) **WIRE CHASE**
 - 4) **BISCUIT PAN HOLDER AND SIDE ITEM DUMP PAN W/ INSERTS**
 - 5) **TWO (2) TEMPERED GLASS PANELS, FOUR (4) GLASS PANEL HOLDERS AND TWO (2) TONG HOLDERS.**

b. Free Standing Model

- 1) **BASE ASSEMBLY - Consisting of the Base Top Assembly, Filler Channel, two (2) Base Legs, REAR Support Strut and Stabilizer plate.**
- 2) **CHICKEN/SIDE ITEM WARMERS, BISCUIT PAN HOLDER AND SIDE ITEM DUMP PAN ASSEMBLY**
- 3) **WIRE CHASE**
- 4) **BISCUIT PAN HOLDER AND SIDE ITEM DUMP PAN W/ INSERTS**
- 5) **TWO (2) TEMPERED GLASS PANELS, FOUR (4) GLASS PANEL HOLDERS AND TWO (2) TONG HOLDERS.**

NOTE: A Wells Food Service Model 100TD Full Size Hot Food Well may be provided in lieu of the Biscuit Pan Holder.

B. INSTALLATION - Assemble the Work Station in the following sequence.

1. Free Standing Model

- a. **BASE ASSEMBLY - Assemble the Work Station Base Assembly at its operating location as follows:**

NOTE: Installation Assembly Instruction are oriented toward assembling a **LEFT HAND** Work Station.

CAUTION: WHEN ASSEMBLING THE WORK STATION ENSURE ALL JOINTS AND SEAMS ARE WITHIN $\frac{1}{32}$ " (.76mm) AND SEALED WITH A NSF APPROVED SEALANT SUCH AS DOW CORNING RTV 732 MULTI-PURPOSE SEALANT.

- 1) **CAREFULLY** place the (2)**Base Top Assembly** flat on the floor with the two (2) 1/4 - 20 **WELD STUDS** on each side facing **UPWARD**.
- 2) Position the (4)**LH Base Leg** with the two (2) 1/4" (6mm) holes in the top bar over the weld studs on the **LEFT** side of the base so that the two (2) 10 -24 nurtserts in the **REAR** leg are facing **INWARD**; then secure the leg to the top using two (2) lock washers, 1/4 - 20 hex and acorn nuts provided.
- 3) Position the (5)**RH Base Leg** with the two (2) 1/4" (6mm) holes in the top bar over the weld studs on the **RIGHT** side of the base so that the two (2) 10 -24 nurtserts in the **REAR** leg are facing **INWARD**; then secure the leg to the top using two (2) lock washers, 1/4 - 20 hex and acorn nuts provided.
- 4) Position the (3)**REAR SUPPORT STRUT** on the **RH** and **LH** base legs and secure it to each leg using two (2) 10-24 truss head screws in the nutserts on each leg.
- 5) **CAREFULLY** place the (8)**Base Assembly UPRIGHT** with the opening to the **FRONT**, install the "triangle" (6)**STABILIZER** shown below to the (4)**LH** or (5)**RH Base Leg** (depending on LH or RH Configuration) and the (2)**Base Top Assembly** by installing a 10-24 X 1/2" (13mm) truss head screw in each 10-24 nutsert. Place the assembly in the position where it is to be operated; then check to be sure it is **LEVEL**. If necessary, adjust the (7)**Bullet Feet** on the base legs to level the assembly.
- 6) **LOCATE** the (1)**Filler Channel** in the (2)**Base Top Assembly** so that the four (4) 1/8" (3mm) holes in the channel are aligned with the holes in the (2)**Base Top Assembly**; Then Secure these items using four (4) pop-rivets and place a bead of NSF Approved sealant on top of the (9)**installed pop-rivet heads**.

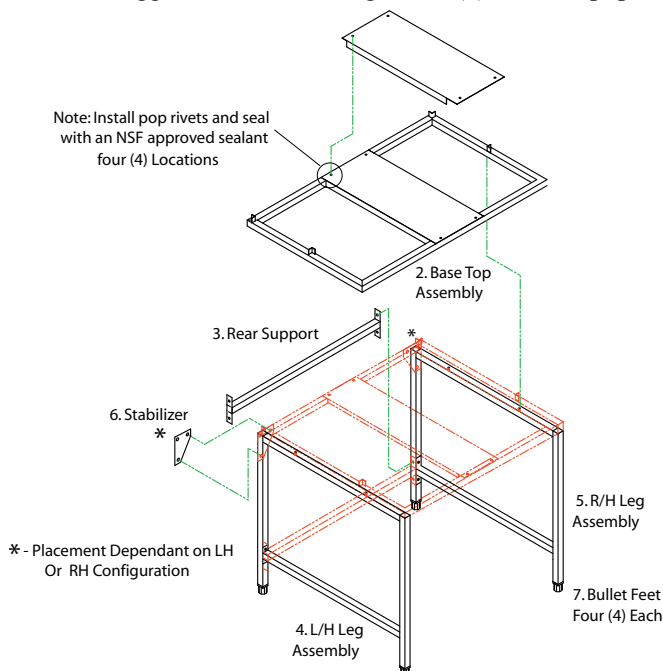

b. CHICKEN / SIDE ITEM WARMERS; BISCUIT PAN HOLDER AND SIDE ITEM DUMP PAN ASSEMBLY

- 1) **CAREFULLY** place the (1)**Chicken Warmer / Side Item Assembly** **ABOVE** the (6)**Base Assembly** so that the four (4) tubular legs of the (1)**Chicken Warmer / Side Item Assembly** are **SEATED** over the four(4) **ANGULAR TABS** on the (6)**Base Assembly** as shown below.
- 2) Install the (3)**Upper** and the (4)**Lower Glass Panel Holder** with the glass **CHANNEL** over the shoulder bolts on the left and right side of the lamp section of the Chicken Warmer.
- 3) Remove stickers from the (2)**Glass Panels** and carefully wash these panels with hot soapy water, rinse and wipe dry with a lint free cloth; then **CAREFULLY** install these panels by sliding them into the glass panel holders from the **REAR** of the Work Station.

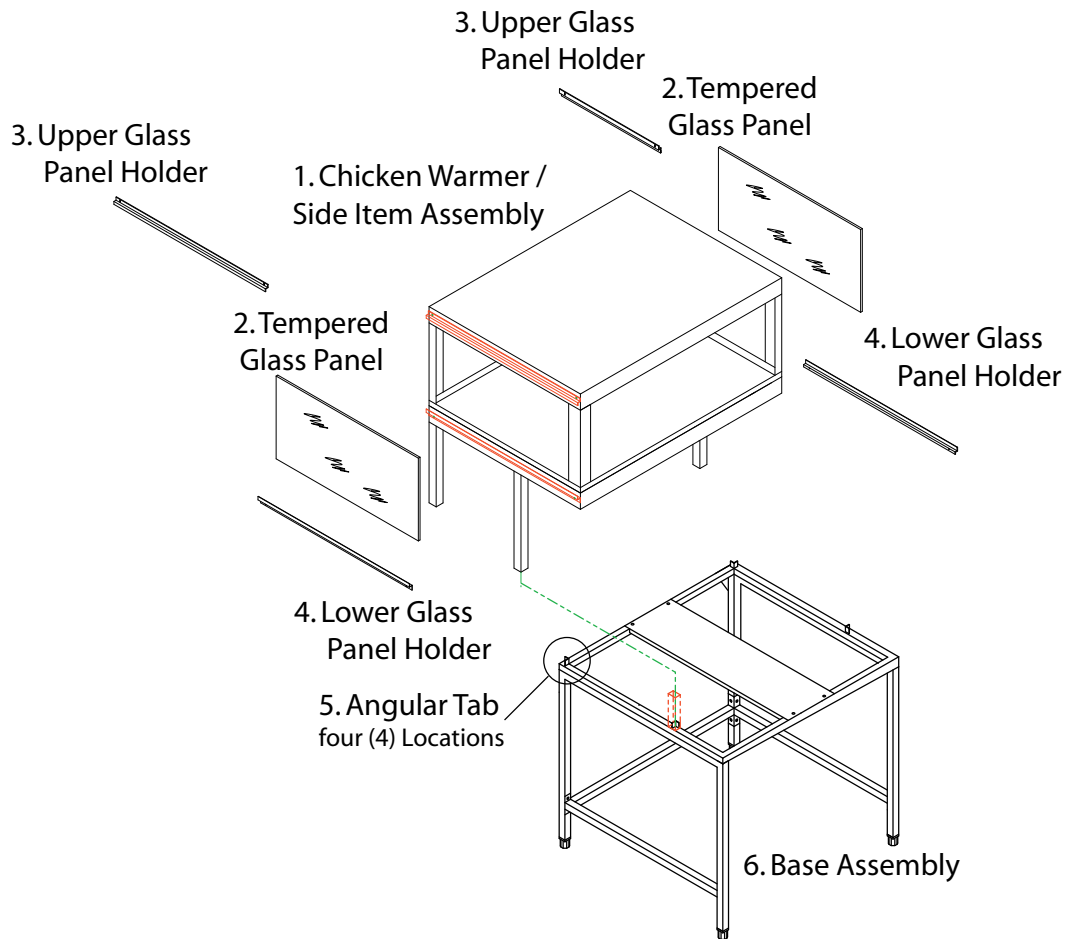

c. WIRE CHASE AND WIRING HARNESS

NOTE: Perform the following steps facing the rear of the Work Station.

- 1) **CAREFULLY** position the Wire Chase, without the cover, against the **RIGHT HAND** edge of the Chicken Warmer and Side Item Warmer, and **RIGHT HAND** Base Assembly leg; then align the four (4) $\frac{9}{32}$ " (7mm) holes in the wire chase with the four (4) 10-24 nutserts in the warmers and base leg.
- 2) When the Wire Chase is properly positioned, **SECURE** the Wire Chase to the Work Station using four(4) hex-head 10-24 x $\frac{3}{4}$ " (19mm) self-tapping screws provided.
- 3) The Chicken Warmer has one (1) electrical circuit (3wires), the Side Item Warmer has one (1) electrical circuit (3wires), and there are four (4) circuits in the Wire Chase for the Biscuit Warmer's ON/OFF Switch, the Amber Lamp and the Electrical Receptacle. Insert the three (3) wires attached to the Chicken Warmer through the upper 1" (25mm) access hole in the wire chase. Insert the three (3) wires attached to the Side Item Warmer through the lower 1" (25mm) access hole in the wire chase.

NOTE: Cable ties are provided for the installer to bundle and separate the wires from the Chicken Warmer, Side Item Warmer, Base Assembly and Biscuit Warmer switch.

- 4) **CAREFULLY** route the three(3) bundles of wires **UP** the Wire Chase; then **CAREFULLY** position the wire chase cover on the wire chase so the eight (8) $\frac{9}{32}$ " (7mm) holes in the cover are aligned with the eight (8) 10-24 x $\frac{1}{2}$ " (13mm) nutserts in the wire chase.
- 5) When the Wire Chase Cover is properly positioned, **SECURE** it to the Wire Chase using the eight (8) 10-24 x $\frac{1}{2}$ " (13mm) truss head screws..
- 6) Have a **LICENSED** Electrician connect the four (4) electrical circuits of the Work Station to the store's main electrical panel and connect the Work Station ground wire to the stores ground system.

NOTE: The biscuit pan heating pad and heat lamps in the chicken / side item warmers require a maximum of 30 amps at 120 Volts electrical power for proper operation. If a built-in food warmer is to be connected to the receptacle on the Work Station wire chase, additional electrical power will be required.

- 7) **ALL** wiring and electrical connections accomplished by the electrician **MUST** conform with the latest edition of the National Electrical Code ANSI.NFPA 70, Canadian CSA C22.1 Canadian Electrical Code Part I, and local electrical codes.

2. CounterTop Model

- a. **BASE ASSEMBLY** - Assemble the Work Station Base Assembly at its operating location as follows:

NOTE: Installation Assembly Instruction are oriented toward assembling a **LEFT HAND** Work Station.

CAUTION: WHEN ASSEMBLING THE WORK STATION ENSURE ALL JOINTS AND SEAMS ARE WITHIN $\frac{1}{32}$ " (.76mm) AND SEALED WITH A NSF APPROVED SEALANT SUCH AS DOW CORNING RTV 732 MULTI-PURPOSE SEALANT.

- 1) **CAREFULLY** place the (4)**Base Assembly**, with the electrical receptacle cutout to the **REAR**, on the counter with the two (2) 1/4-20 **WELD STUDS** on each side facing **UPWARD**.
- 2) Align the holes on the (2)**Base Frame** with the weld studs on the (4)**Base Assembly** so that the weld studs protrude thru the (2)**Base Frame**. **SECURE** these items using four (4) 1/4-20 lock washers, hex and acorn nuts provided.
- 3) Repeat step B1a (6) page 6 to secure the (3)Filler Channel to the (2)Base Frame.
- 4) **CAREFULLY** place the (1)**Chicken Warmer / Side Item Assembly** **ABOVE** the (10)**Base Frame Assembly** so that the four (4) tubular legs of the (1)**Chicken Warmer / Side Item Assembly** are **SEATED** over the four (4) **ANGULAR TABS** on the (2)**Base Frame Assembly** as shown below.
- 5) Repeat steps B1b 1) through B1b 4) page 7 to install the Chicken / Side Item Warmers, Biscuit Pan Holder and Side Item Dump Pan.
- 6) Repeat steps B1c 1) through B1c 7) page 8 to install the Wire Chase and Wiring Harness.

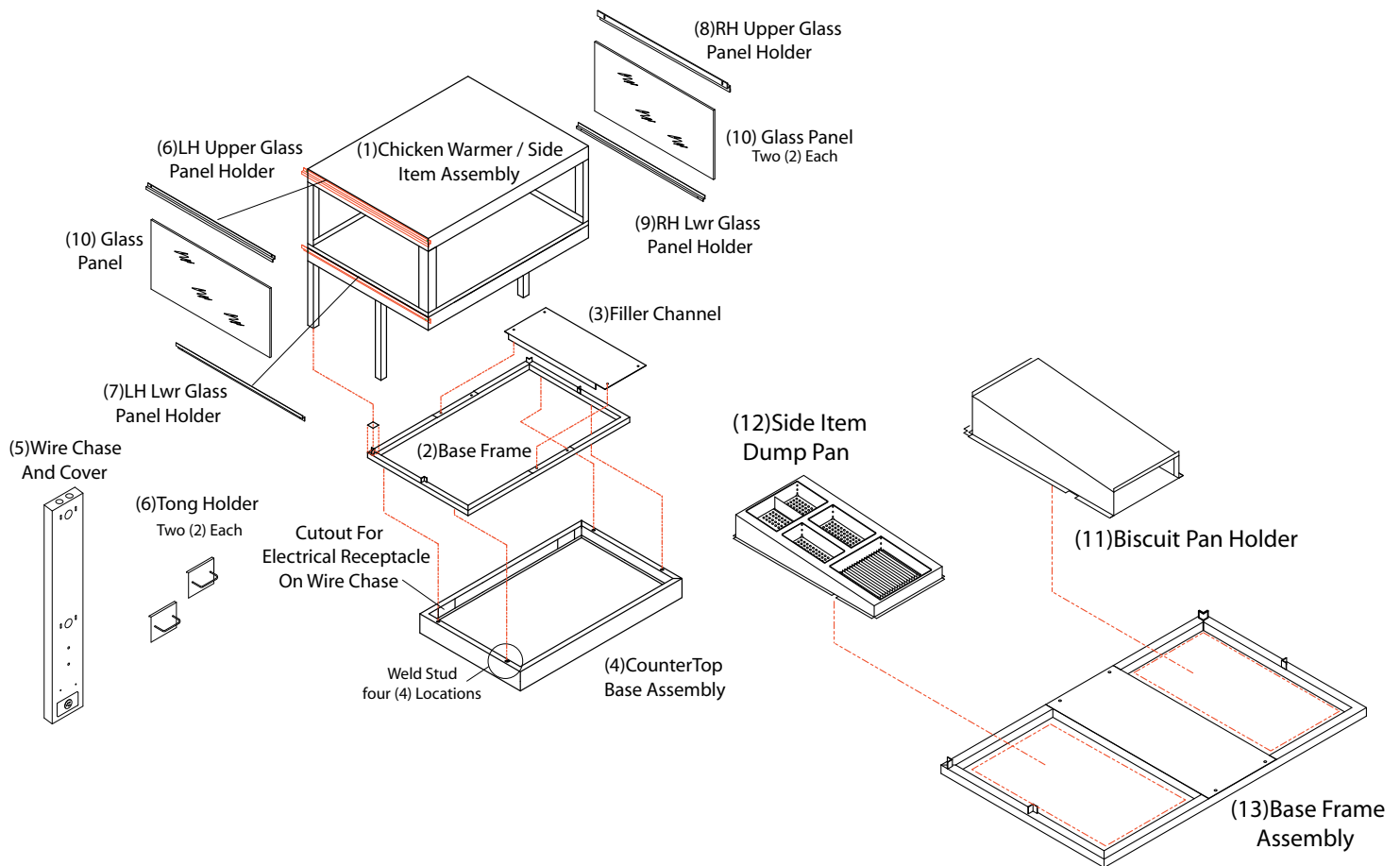

C. CLEANING

1. **THOROUGHLY** inspect the Chicken and Side Item Warmers which will come in contact with food for crevices that have not been sealed with silicone. Any crevices found **MUST** be sealed with an NSF approved sealant such as Dow Corning RTV732 Multi-Purpose Sealant.
2. **THOROUGHLY** wash the following items with **HOT** sanitizer Solution to remove oil film, manufacturing residue, etc.; then rinse and wipe these items dry with lint free cloths:
 - a) Chicken Warmer and Chicken Pans / Baskets.
 - b) Side Item Warmer; Biscuit Pan Holder; Side Order Dump Pans, Screens, Dividers and Tong Holders.

D. SIDE ITEM DUMP PAN INSERTS

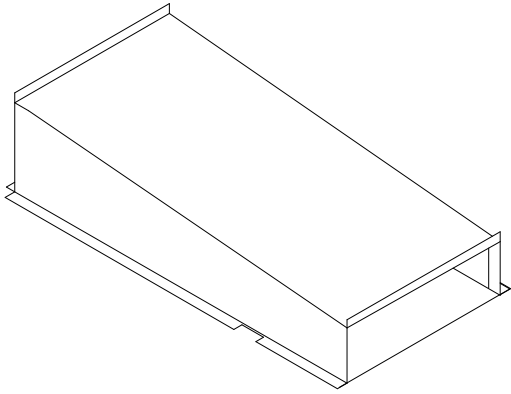

Biscuit Pan Holder

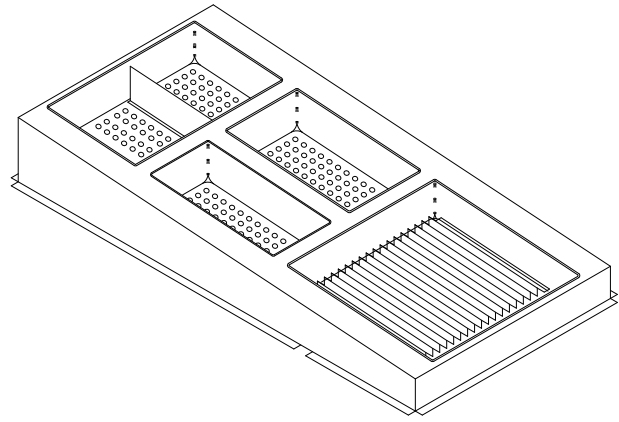

(9) Completed Side Order Pan Assembly

Pan Inserts

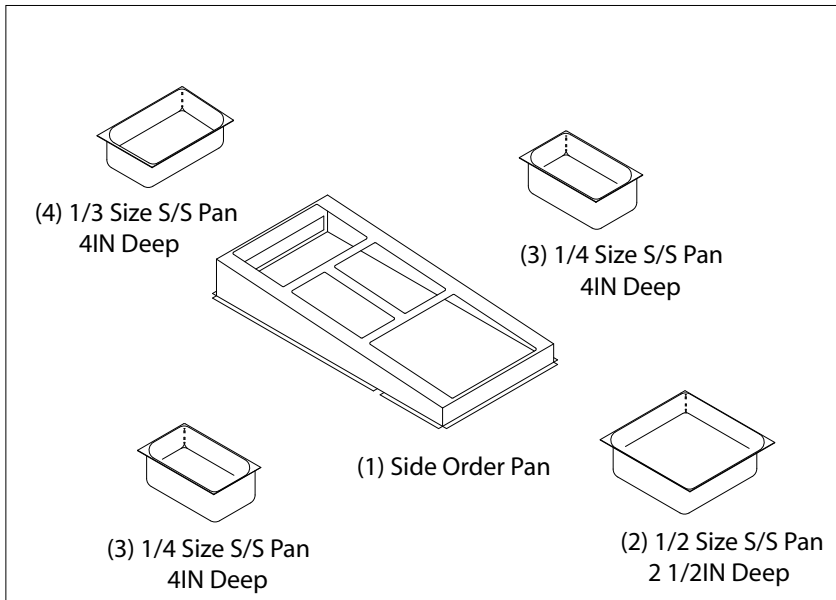

Grill Inserts

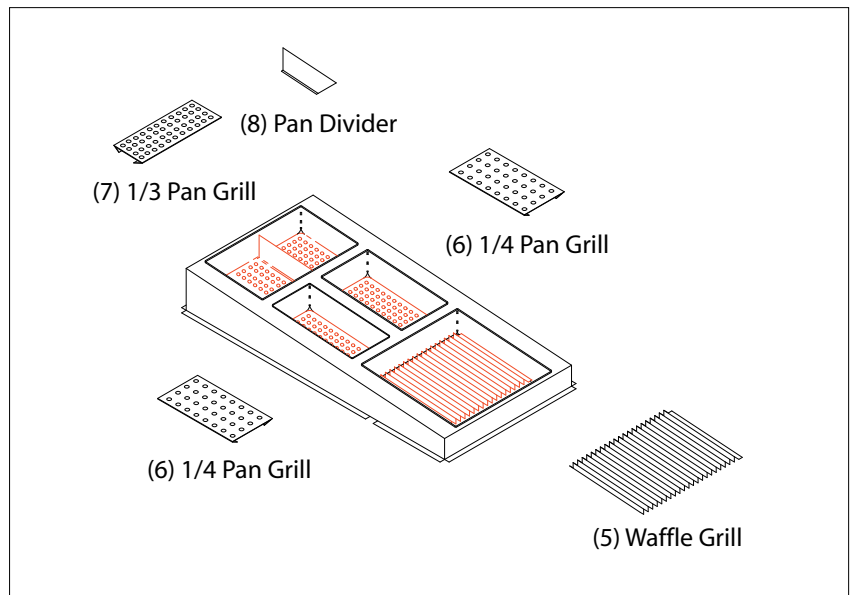

1. Assemble and install the following **CLEAN** items beneath the Side Item Warmer as requested by the store manager.

- a) **BISCUIT PAN HOLDER** - Place the (9)**Biscuit Pan Holder** in the (10)**Base Frame Assembly** as illustrated below. When properly positioned, connect the electrical plug for the biscuit pan heater in the single receptacle on the wire chase.
- b) **SIDE ITEM DUMP PANS** - Assemble the (8)**Side Item Dump Pan** as shown on page 10; then place the (8)**Side Item Dump Pan** (with inserts) adjacent to the (9)**Biscuit Pan Holder** in the (10)**Base Frame Assembly**.
- c) **TONG HOLDER** - Place a (11)**Tong Holder** on each side of the (12)**Chicken Warmer / Side Item Assembly**..

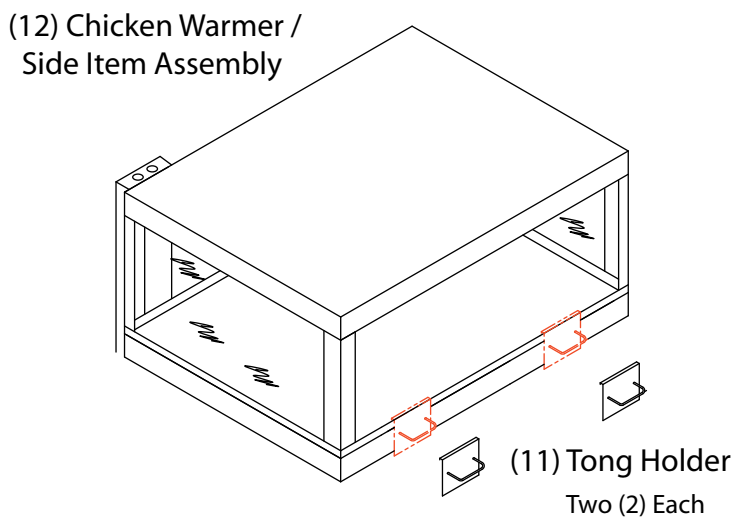
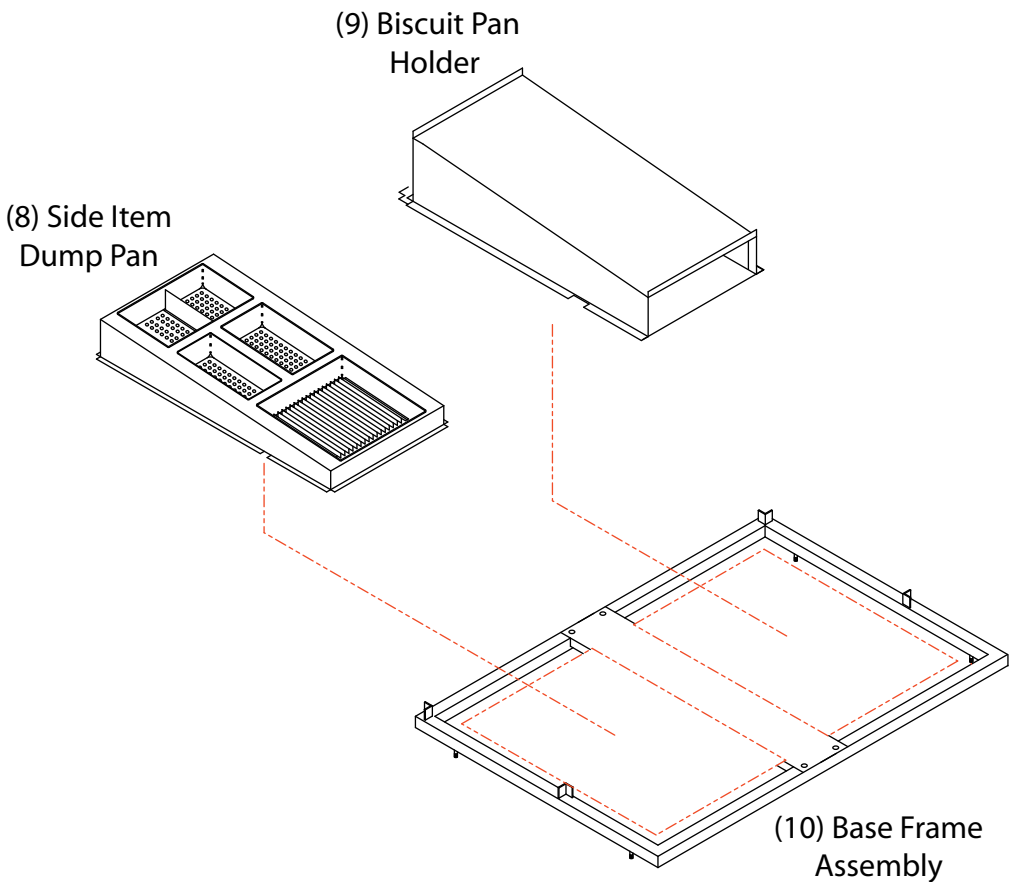

FREE STANDING WORK STATION OPTIONAL ACCESSORIES

A. GENERAL - Four (4) optional accessories are available **ONLY** for use with the Free Standing Model Work Station. If one (1) of these accessories is requested at the time of the **ORIGINAL** order, the Work Station will be built to accommodate the accessory such as:

- (1) Full Size Food Warmer
- (2) Disher Well Sink and Water Faucet
- (3) Okra Dump Pan, Salt, Scoop and French Fry Bag Holder
- (4) Storage Cabinet

NOTE: IF A STORAGE CABINET IS REQUESTED, A FOOD WARMER AND A DISHER WELL SINK AND FAUCET CAN NOT BE INSTALLED.

When an optional accessory is requested, the Biscuit Pan Holder will be OMITTED. Information and Installation instructions of these optional accessories are as follows:

1. Built-in Model 100TD Food Warmer - If the Work Station is to be provided with a Food Warmer in lieu of a Biscuit Pan Holder, install it as follows:

- (a) **GENERAL** - Space will be made available in the Base Frame Assembly adjacent to the Side Item Dump Pan for the Model 100TD Food Warmer. A mounting plate is provided to mount the Warmer's Thermostat Control Panel on the **FRONT** of the **LH Side Leg** and **Base Frame Assembly**. Additionally, a 3/4" (19mm) Ball Valve is attached to the Warmer's drain.
- (b) **INSTALLATION** - Install the Full Size Food Warmer as follows:
 - 1) **CAREFULLY** lower the food Warmer and Thermostat Control Panel into the Base Top Assembly, adjacent to the Side Item Dump Pan until it is firmly **SEATED**.
 - 2) Install the Mounting Plate for the Thermostat Control Panel to the **FRONT** of the Work Station using 10-24 x 1/2" (13mm) truss head screws in the 10-24 nutserts in the Base Frame. Once the Plate is **SECURE**, attach the Thermostat Control Panel to the Plate using the hardware provided.
 - 3) Have a licensed plumber provide and install a water drain from the 3/4" (19mm) Ball Valve to a floor drain.
 - 4) Connect the Food Warmer's electrical plug to the single outlet on the Wire Chase.

NOTE: The two (2) Quartz Warmer Lamps for the Biscuit Pan Holder were omitted from the Side Item Warmer

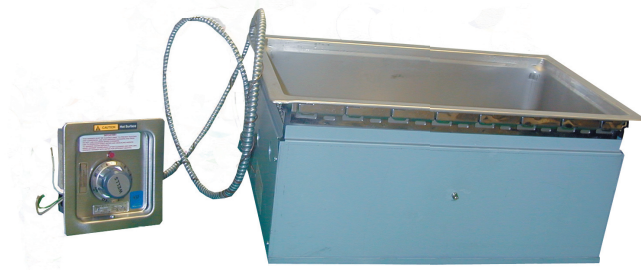

2. Disher Well Sink and Water Faucet

- (a) **GENERAL**- A Mounting Plate with a 5 1/5" (140mm) and a 7/8" (22mm) diameter hole will be provided for the Disher Well Sink and Water Faucet.
- (b) **INSTALLATION** - These items are to be installed by a licensed plumber who will also be responsible for providing and connecting the items to a water line and floor drain.



3. Okra Dump Pan and Inserts

- (a) GENERAL - Space will be available in the Base Top Assembly adjacent to the Side Item Dump Pan for the Okra Dump Pan.
- (b) INSTALLATION - Inserts for the Okra Dump Pan are to be installed as follows:

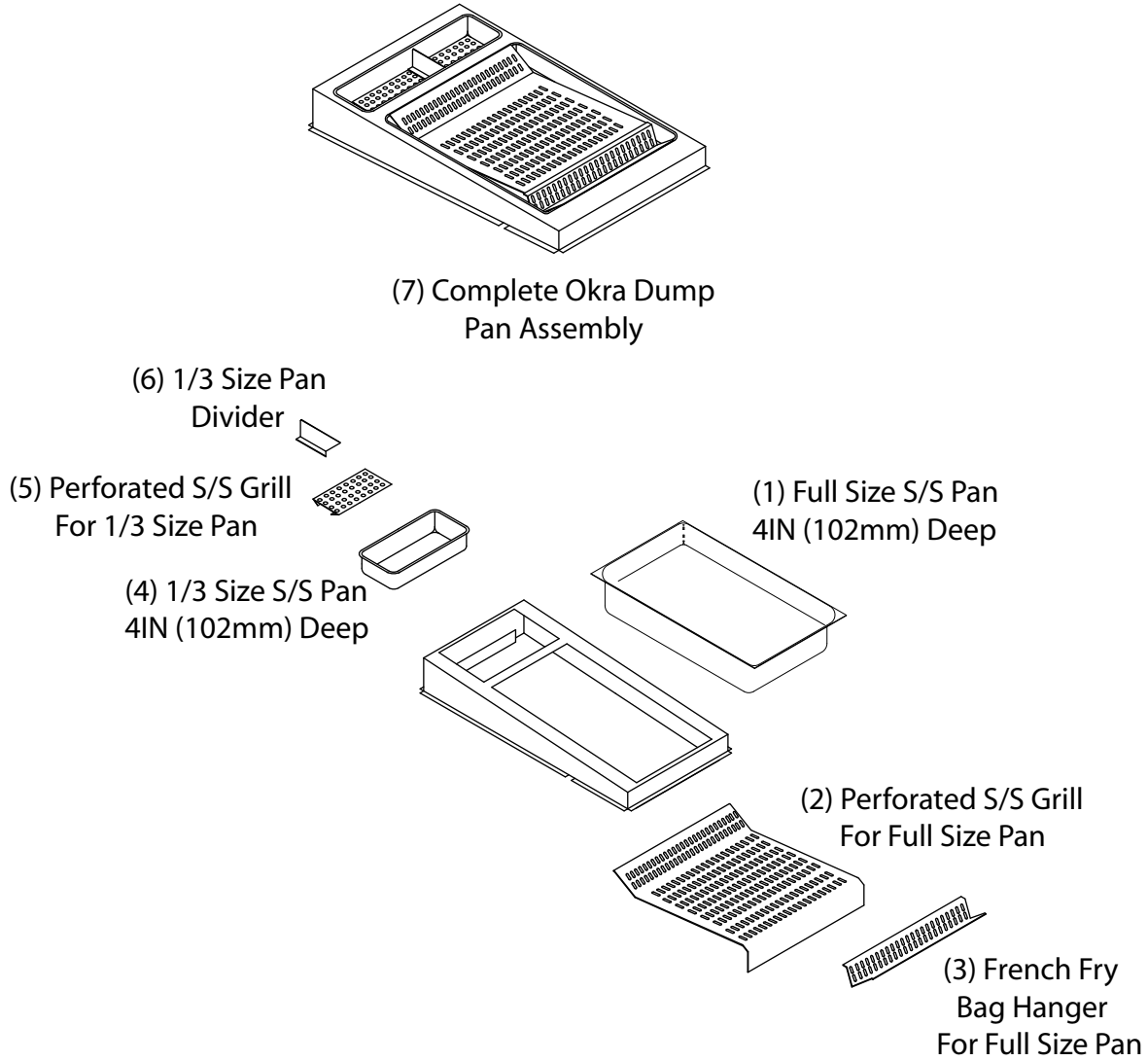

1	Full Size S/S Pan 4" (102mm) Deep	21698
2	Perforated S/S Grill For Full Size Pan	NOTE 1
3	French Fry Bag Holder	NOTE 2
4	1/3 Size S/S Pan 4" (102mm) Deep	21A309
5	Perforated Grill For 1/3 Size Pan	NOTE 3
6	1/3 Size Pan Divider	NOTE 4
7	Complete Okra Dump Pan Assembly	12B132
These items have to be "Special Ordered"		
NOTE 1: Specify as Part Number 3 of 12B132 Drawing #12B132		
NOTE 2: Specify as Part Number 4 of 12B132 Drawing #12B132		
NOTE 3: Specify as Part Number 5 of 12B132 Drawing #12B132		
NOTE 4: Specify as Part Number 6 of 12B132 Drawing #12B132		

NOTE: Hang the Scoop, Salt and Bag Holder on the Side Item Warmer Between the two (2) Tong Holders

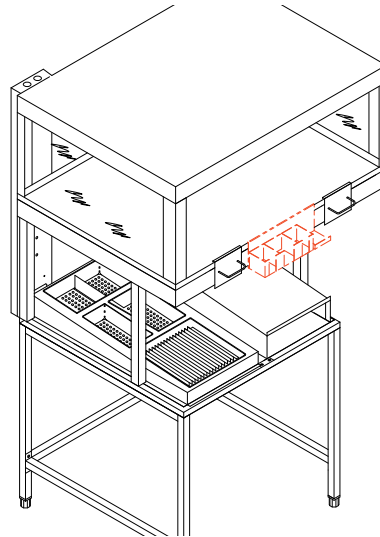
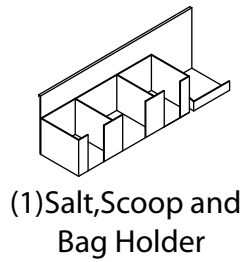

4. Storage Cabinet

(a) GENERAL - The 37" (940mm) x 24" (610mm) x 30" (762mm) S/S Storage Cabinet consists of: The Cabinet Box, two (2) Rear Gussets, two (2) pieces of 1 5/8" Tubing and two (2) Bullet Feet.

(b) INSTALLATION - The Storage Cabinet is to be installed as follows:

- 1) Align the two (2) holes in the TOP of the Cabinet and the two (2) holes on the SIDE of the Cabinet with the nutserts in the Base Top Assembly and the L/H Front Leg.
- 2) Install a 10-24 x 1/2" (13mm) truss head screws in each nutsert.
- 3) Adjust the Bullet Feet on the Rear gussets until the Cabinet is supported and LEVEL.

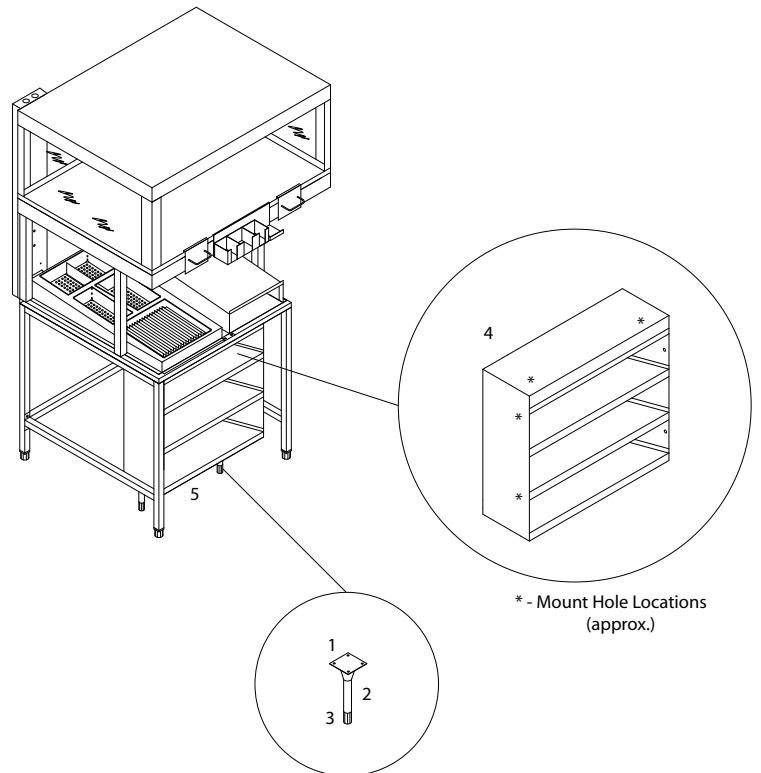

1	Klein Leg Socket	22124
2	1 5/8" S/S Tubing	14001
3	Bullet Feet	22022
4	Cabinet Storage 37 x 24 x 30	12B335

SERVICE & PARTS

1. **TECHNICAL ASSISTANCE** - Contact an authorized service agent or the Customer Service Department, Ultrafryer Systems at 1-800-525-8130 for technical assistance.

2. **ORDERING INFORMATION:**

A. **REPLACEMENT PARTS** - Provide the following information when ordering replacement parts by phone, fax or mail:

Your company name and phone number
Your company purchase order number
Bill-to address
Ship-to address
Quantity desired
Part number and description of the desired-item
Your name or signature of authorized-buyer
Phone in order to: 1-800-545-9189 Ext 5029
FAX order to: 1-210-731-5099
Mail order to: Ultrafryer Systems
Order Entry Office
P.O. Box 5369
San Antonio, TX 78201
E-Mail your order to: Ultrafryerservice@ultrafryer.com

B. **TERMS** - Net 30 days for customers on open accounts. Past due balances will be charged 1 % per month (12% per annum) until full balance is paid.

C. **DAMAGES** - Ultrafryer Systems is not responsible for damage occurring in transit. All deliveries must be inspected for damage to shipping containers prior to departure of the delivering carrier. Any damage must be notated on the receiving document to facilitate filing of freight claims. Carriers must be notified immediately and freight inspections must be requested from the carrier. Ultrafryer Systems can and will gladly assist you in preparing and processing of the necessary claims only if proper notification has been accomplished on the carrier delivery document. Damaged equipment and or containers must be available for the claims inspector to inspect.

D. **RETURNS** - Ultrafryer Systems cannot guarantee credit for items returned without proper authorization. All returns must have prior Ultrafryer Systems Customer Service or Warranty department approval. An assigned number will be issued by the approval authority. Please print the assigned number on all returned packages and corresponding paperwork. Returned goods are subject to a 15% restocking charge. Ultrafryer Systems is not responsible for freight charges on returned goods unless authorized by Customer Service and or Warranty personnel. Ultrafryer Systems does not receive freight collect or C.O.D. shipments.

3. **PARTS IDENTIFICATION** - Locate the part on the following sketches and note the index number i.e, 4, 7, etc; then obtain the part number and description for that index number on the right side of the page facing the sketch. Use that part number when ordering a replacement part.

**COUNTERTOP / FREE STANDING MODEL
40IN WORK STATION**

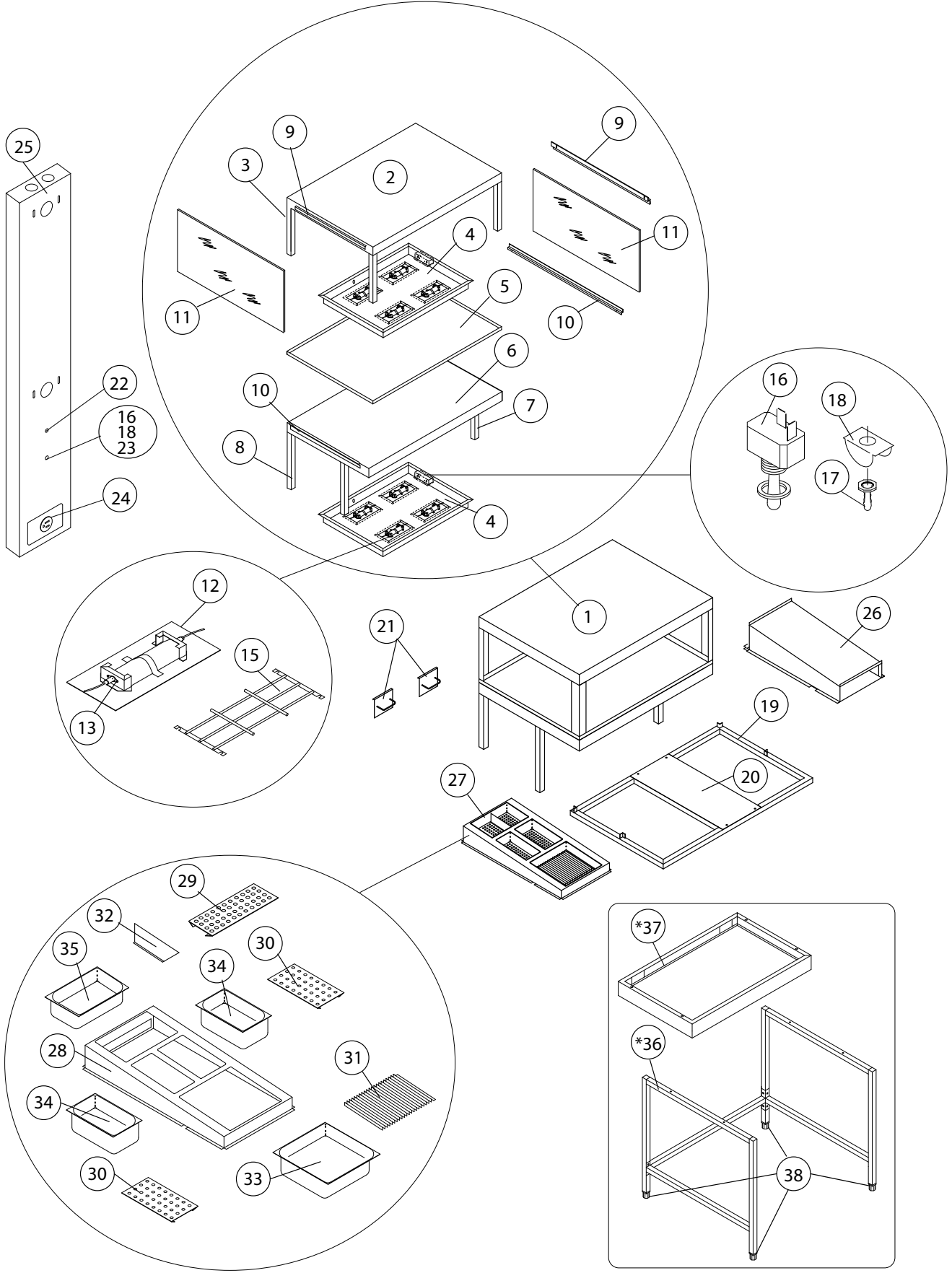

**COUNTERTOP / FREE STANDING MODEL
40IN WORK STATION**

<u>ITEM</u>	<u>QTY</u>	<u>DESCRIPTION</u>	<u>PN</u>
1	1	Chicken / Side Item Warmer Assembly	12B099
2	1	Top Lamp Housing (Part #1)	11A45105
3	4	Chicken Display Support (Part #7)	11A45107
4	2	Light Panel Assembly	12A739
5	1	Chicken Display Shelf (Part #3)	11A45105
6	1	Bottom Lamp Housing (Part #3)	11A45105
7	2	Overhead Lamp Support, FRONT (Part #12)	11A45107
8	2	Overhead Lamp Support, REAR (Part #8)	11A45107
9	2	Tempered Glass Holder TOP (Part #4)	11A45106
10	2	Tempered Glass Holder BOTTOM (Part #15)	11A45106
11	2	12" (305mm) 29 1/2" (746mm) Tempered Glass Panel	22A102
12	8	Quartz Warmer Lamp Assembly	12B098
13	16	GE AL1881705 Quartz Lamp Holder	18077
*	8	Replacement 120V 375 Watt QH375T317 Quartz Warmer Lamp	18084
15	8	Quartz Warmer Lamp Guard	19573
16	3	125/250 Volt 15/10 Ampere SPST Toggle Switch	18204
17	2	Protective GRAY Rubber Boot For Toggle Switch	23402
18	3	Toggle Switch Guard	18129
19	1	Base Top Assembly (Part #9 & Part #10)	11A45107
20	1	Filler Channel (Part #5)	11A45106
21	2	Tong Holder	12A406
22	1	120 Volt 1/3 Watt Snaplight with AMBER Lens	23A056
23	1	Protective RED Rubber Boot For Toggle Switch	22A104
24	1	NEMA 5-15R Type 5015 Single Device Electrical Receptacle	33012
25	1	Wire Chase Assembly	12A738
26	1	Biscuit Pan Holder	12A404
27	1	Side Item Dump Pan Assembly	12B052
28	1	Side Order Pan Frame (Part #1)	12B052
29	1	1/3 Size Pan Perforated Grill For Pan 21A309 (Part #2)	12B052
30	2	1/4 Size Pan Perforated Grill For Pan 21A308 (Part #3)	12B052
31	1	Waffle Grill For 1/2 Size Pan 21A311	12B054
32	1	1/3 Size Pan Divider (Part #4)	12B052
33	1	1/2 Size S/S Pan 2 1/2" (64mm) Deep	21A311
34	2	1/4 Size S/S Pan 4" (102mm) Deep	21A308
35	1	1/3 Size S/S Pan 4" (102mm) Deep	21A309
36	1	1 1/2" (38mm) Square Tubing Base Leg Assembly (Free Standing Model Only)	12A632
37	1	CounterTop Base Assembly (CounterTop Model Only)	NOTE 1
38	4	Ajustable S/S Bullet Feet (Free Standing Model Only)	22A101

* - NOT SHOWN

NOTE 1 - This item will have to be "Special Ordered". When ordering identify part as Drawing 1145102.

WIRING DIAGRAM

CHICKEN WARMER

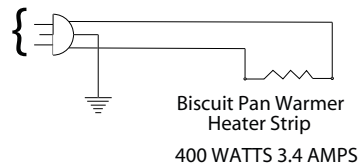
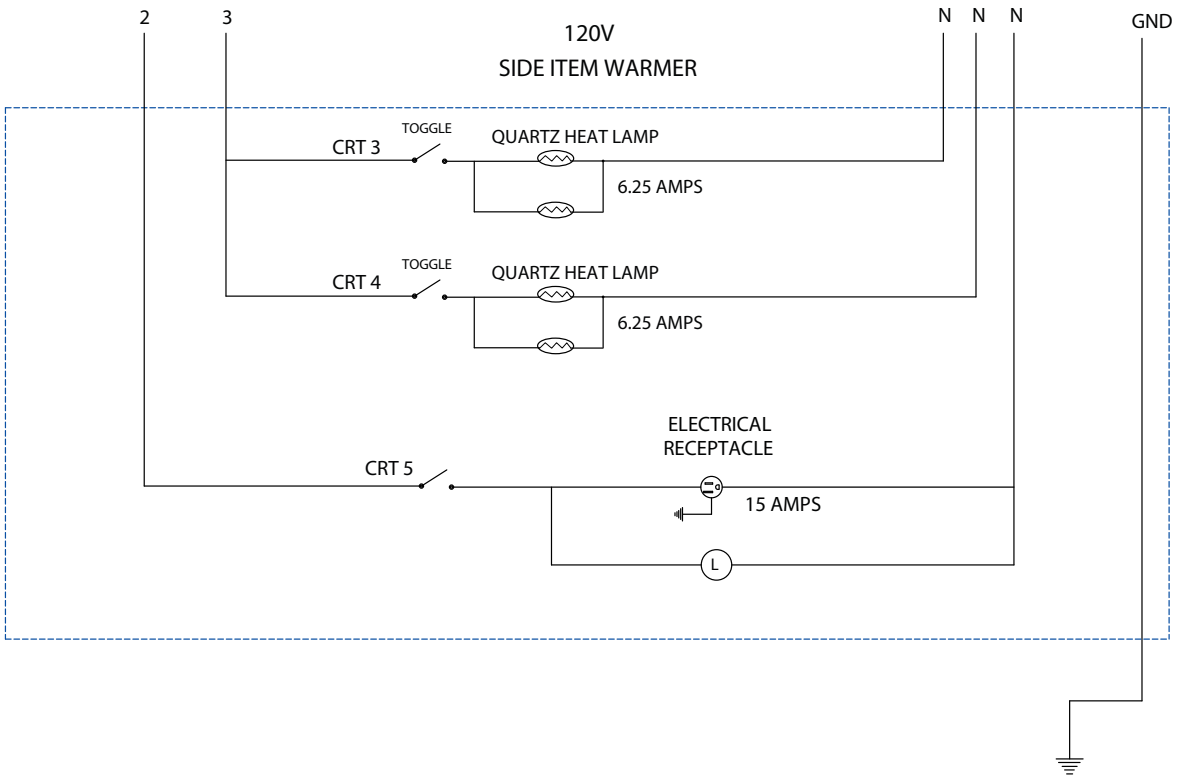
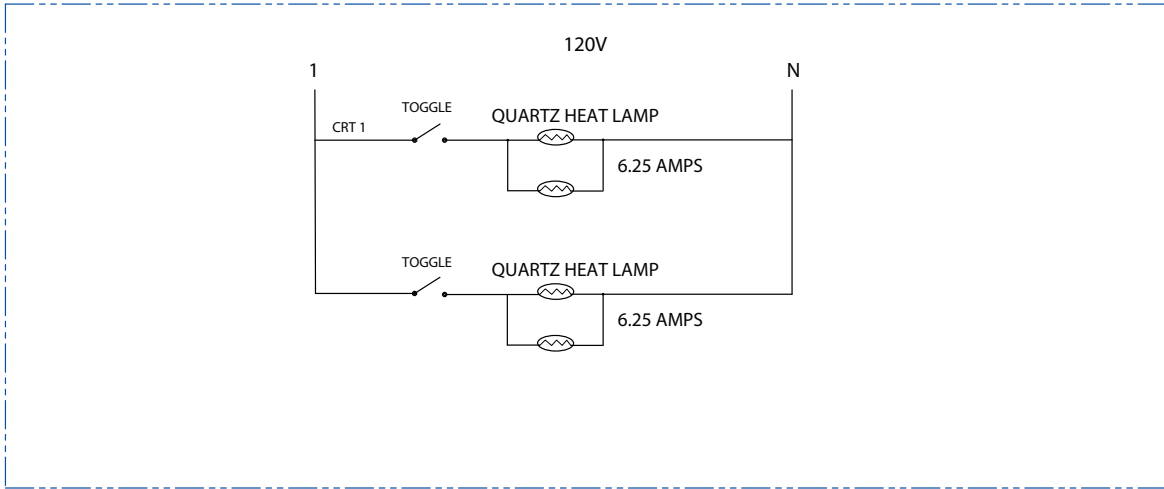

THIS PAGE INTENTIONALLY BLANK