



# “HE” Type Filtration Procedures

**WARNING :** TO ASSURE PRODUCING A QUALITY PRODUCT WHILE PROLONGING THE LIFE EXPECTANCY OF THE FRYER, ENSURE FILTERING, BOIL-OUT AND CLEANING INSTRUCTIONS ARE STRICTLY ADHERED TO



---

302 Spencer Lane • P.O. Box 5369

(800) 525-8130 • (210) 731-5000 • Fax: (210) 731-5099  
[www.ultrafryer.com](http://www.ultrafryer.com)

San Antonio, Texas 78201



## 14" Model EUHE / ELHE Electric Fryer With Hard Dock Filtration

THIS APPLIANCE IS FOR PROFESSIONAL USE AND IS TO BE USED ONLY BY QUALIFIED PERSONNEL

# Contents

## OPERATING INSTRUCTIONS

Filter Tub Assembly and Filter Screen. . . . .	Pg: 3
Filtering Tub Assembly and Installation. . . . .	Pg: 5
Filter Shortening . . . . .	Pg: 6
Boiling Out Fryer . . . . .	Pg: 9
Leveling Shortening. . . . .	Pg: 11
Technical Assistance & Ordering Information . . . . .	Pg: 12-16

1. The Filter Tub Assembly and Filter Screen should be cleaned EACH DAY after FILTERING and AT CLOSING and THOROUGHLY cleaned once each week. To remove the Filter Tub Assembly from the fryer:
  - a) OPEN the Fryer's Temperature Control Access Door,
  - b) DEPRESS the DOCKING RELEASE HANDLE , shown on page 34.
  - c) PULL the Filter Tub Assembly from the fryer.
  - d) Disassemble the Filter Tub Assembly in the following sequence:
    - 1). filter tub cover
    - 2) crumb catcher screen
    - 3) filter screen standpipe/docking assembly; then separate the standpipe/docking assembly from the filter screen
  - e) Clean the Filter Tub and Filter Screen as follows:

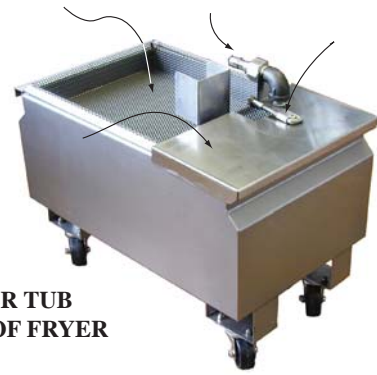

**FILTER TUB  
OUT OF FRYER**

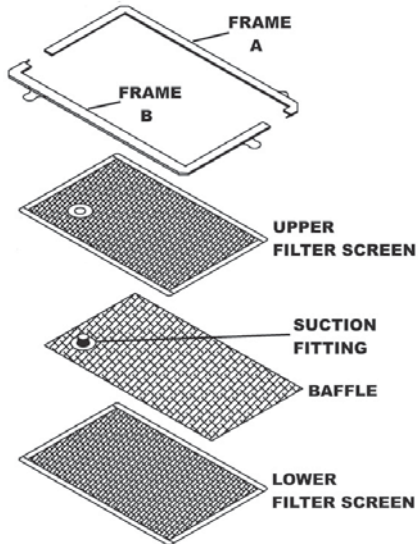

NOTE: Magnepad Filter Pad not shown

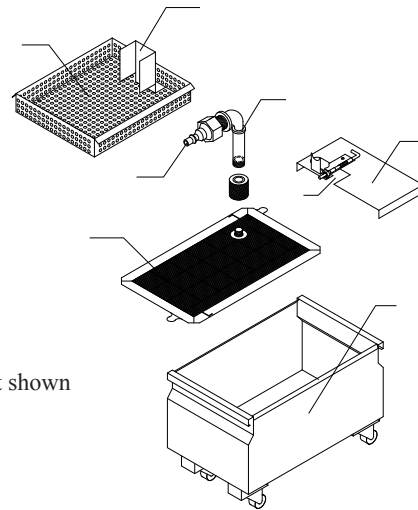

## 2. CLEANING THE FILTER TUB AFTER FILTERING SHORTENING

- a. Disassemble the Filter Machine by removing the following items in the order listed; 1) FILTER TUB COVER, 2) CRUMB CATCHER SCREEN , 3) FILTER SCREEN W/STANDPIPE/DOCKING attached ; then 4) separate the STANDPIPE and DOCKING ASSEMBLY from the Filter Screen.
- b. Clean the Wash Down Hose with sanitizer solution; then hang the Wash Down Hose in an upright position so shortening can drain into a container.
- c. Discard crumb fragments in the Crumb Catcher Pan and THOROUGHLY clean the pan with HOT water and let it air dry.
- d. Raise the Filter Assembly with Standpipe and Docking Assembly attached, above the Filter Tub and let any sediment or shortening drain into the tub; then separate the standpipe/docking assembly from the Filter Screen and clean the assembly with sanitizer solution and wipe it dry with a lint free cloth. THOROUGHLY clean the filter assembly as follows:
  - 1) "Micro-Mesh" Stainless Steel Filter Screen
    - a) CAREFULLY remove any debris from the screen using a scraper.
    - b) Grasp the FINGER LOOP on FRAME A and adjacent FINGER LOOP on FRAME B , EVENLY pull the frames apart; then HINGE FRAME A to remove it from the FILTER SCREENS FIRST.
    - c) Grasp the FINGER LOOP on the straight side of FRAME B ; then HINGE it to remove FRAME B from the FILTER SCREENS.
    - d) Separate the UPPER FILTER SCREEN and BAFFLE from the LOWER FILTER SCREEN .
    - e) CAREFULLY clean the two frames, screens and baffle in the 3 compartment sink with hot water and allow these items to air dry. DO NOT USE SOAP. If necessary the channels in each frame can be cleaned with the edge of a scotchbrite pad.
    - f) Insert the SUCTION FITTING on the BAFFLE in the hole of the UPPER FILTER SCREEN; then place these items on top of the LOWER FILTER SCREEN.
    - g) ENSURE all sides of the FILTER SCREEN assembly are aligned, place the PIN end of FRAME A on the FILTER SCREENS , place the CHANNEL on the frame adjacent to the PIN end over the FILTER SCREENS;

then HINGE the frame so the edge of the FILTER SCREENS are inserted in the other CHANNEL of FRAME A.

- h) Place the PIN end of FRAME B on the FILTER SCREENS so the PIN is seated in the CHANNEL of FRAME A near the FINGER LOOP , place the CHANNEL on the frame adjacent to the PIN end over the edge of the FILTER SCREENS; then HINGE the frame so the edge of the FILTER SCREENS are inserted in the other CHANNEL of FRAME B and the PIN of FRAME A is seated in the CHANNEL of FRAME B.
  - i) Adjust FRAME A and B so both PINS are properly seated in the CHANNEL of the opposite frame; then CAREFULLY connect the KNURL KNOB on the STANDPIPE/DOCKING ASSEMBLY to the SUCTION FITTING on the FILTER SCREEN assembly. DO NOT OVERTIGHTEN!!!
- \* \* 2) Magnepad Envelope Filter: Magnepad Filter Assemblies DO NOT have to be SCRAPED after filtering shortening.
- e. Remove any sediment and shortening in the Filter Tub using a scraper; then wipe the tub dry with paper towels.
  - f. CAREFULLY insert the assembled Filter Screen in the bottom of the Filter Tub; then CAREFULLY insert the Crumb
  - g. CAREFULLY position the FILTER TUB COVER on the OPEN end of the Filter Tub with the SLOT on the cover seated around the Standpipe/Docking Assembly. Then, SECURE the cover to the standpipe assembly by locking the latch on the cover.
  - h. Position the ASSEMBLED Filter Tub in front of the FILTER TUB GUIDES beneath the fryer; then CAREFULLY and SLOWLY insert the Filter Tub into the fryer until the MALE In Line Plug on the Docking Assembly seats in the FEMALE Bulkhead Coupling adjacent to the Drain Valve Assembly.

### 3 . CLEANING THE FILTER TUB AFTER CLOSING

#### a. "Micro Mesh" Stainless Steel Filter Screen:

Repeat DAILY steps A 1 page 21; then, THOROUGHLY clean the Filter Assembly as follows:

- 1) THOROUGHLY flush any remaining sediment from both sides of the filter screen with HOT WATER.
- 2) Grasp the FINGER LOOP on FRAME A and adjacent FINGER LOOP on FRAME B , EVENLY pull the frames apart; then HINGE FRAME A to remove it from the FILTER SCREENS FIRST.
- 3) Grasp the FINGER LOOP on the straight side of FRAME B ; then HINGE it to remove FRAME B from the FILTER SCREENS.
- 4) Separate the UPPER FILTER SCREEN and BAFFLE from the LOWER FILTER SCREEN. CAREFULLY clean the two frames, screens and baffle in the 3 compartment sink with hot water and allow these items to air dry. DO NOT USE SOAP. If necessary the channels in each frame can be cleaned with the edge of a scotchbrite pad.
- 5) Insert the SUCTION FITTING on the BAFFLE in the hole of the UPPER FILTER SCREEN; then place these items on top of the LOWER FILTER SCREEN.
- 6) ENSURE all sides of the FILTER SCREEN assembly are aligned, place the PIN end of FRAME A on the FILTER SCREENS, place the CHANNEL on the frame adjacent to the PIN end over the FILTER SCREENS; then HINGE the frame so the edge of the FILTER SCREENS are inserted in the other CHANNEL of FRAME A.
- 7) Place the PIN end of FRAME B on the FILTER SCREENS so the PIN is seated in the CHANNEL of FRAME A near the FINGER LOOP , place the CHANNEL on the frame adjacent to the PIN end over the edge of the FILTER SCREENS; then HINGE the frame so the edge of the FILTER SCREENS are inserted in the other CHANNEL of FRAME B and the PIN on FRAME B is seated in the CHANNEL of FRAME A.
- 8) Adjust FRAME A and B so other PINS are properly seated in the CHANNEL of the opposite frame; then CAREFULLY connect the KNURL KNOB and STANDPIPE/DOCKING ASSEMBLY to the SUCTION FITTING on the FILTER SCREEN assembly. DO NOT OVERTIGHTEN!!!

#### b. "Magnepad" Envelope Filter: \* \* OPTIONAL \* \*

Remove and discard the USED Filter Pad Envelope. CAREFULLY clean the Baffle Assembly and Clip/Stand-pipe assembly in the 3 compartment sink with HOT water and allow these items to air dry. DO NOT USE SOAP!!

Reassemble the Magnepad Envelope Filter using a NEW Magnesol Impregnated Filter Pad Envelope as follows:

- 1) Insert the BAFFLE into the FILTER PAD ENVELOPE , when properly inserted the SUCTION FITTING will protrude through the hole in the pad.
- 2) Fold the FLAP over (in the direction of the hole) securing the Baffle inside the FILTER PAD ENVELOPE .
- 3) CAREFULLY align the CLIP & STANDPIPE ASSEMBLY so that the clip can secure the FLAP and the envelope and the STANDPIPE will align over the SUCTION FITTING protruding through the envelope.
- 4) Tighten the knurled NUT on the STANDPIPE to the SUCTION FITTING protruding through the envelope.
- 5) Repeat DAILY steps A 1 through A 4 pages 21,22 and above.

## FILTER TUB ASSEMBLY AND INSTALLATION

A. **FILTER TUB ASSEMBLY** - ENSURE all components of the filter tub have been thoroughly cleaned and that the Filter Screen has been assembled according to the Cleaning Section, page 22 paragraph A3 of this manual then assemble the filter tub as follows:

1. Connect the **KNURLED KNOB** to the **STANDPIPE/DOCKING ASSEMBLY**; then attach this assembly to the **SUCTION FITTING** on the Filter Screen.  
**DO NOT OVERTIGHTEN THIS CONNECTION!!!**
2. **CAREFULLY** place the Filter Screen in the bottom of the Filter Tub with the screen butted against the rear wall of the tub.
3. **CAREFULLY** insert the Crumb Catcher Screen in the Filter Tub with the Drain Valve **DOCKING FLANGE** and **MALE DOCKING PLUG** over the leading edge of the pan.
4. **CAREFULLY** position the **FILTER TUB COVER** on the open end of the Filter Tub with the **SLOT** on the cover seated around the Standpipe/Docking Assembly. Then, **SECURE** the cover to the standpipe assembly by locking the latch on the cover. (See photo on next page.)

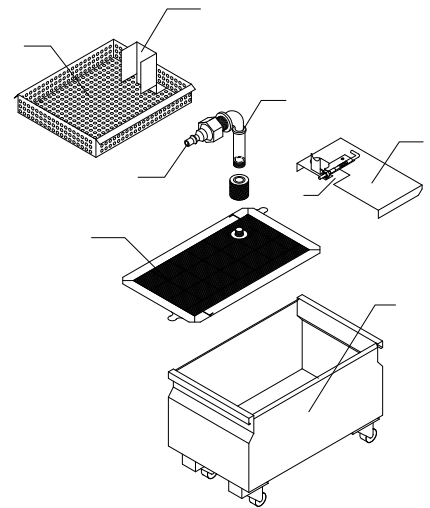

B. **FILTER TUB INSTALLATION** - Position the **ASSEMBLED** Filter Tub in front of the **FILTER TUB GUIDES** beneath the fryer; then **CAREFULLY** and **SLOWLY** insert the Filter Tub into the fryer until the **MALE In-Line Plug** on the Docking Assembly seats in the **FEMALE Bulkhead Socket** adjacent to the Drain Valve Assembly as shown on the next page.

## FILTERING AND POLISHING SHORTENING

### A. FILTERING SHORTENING

1. Turn the **TOGGLE SWITCH** to the fryer **OFF**, and ensure the filter tub is properly docked beneath the drain valve.

**NOTE:** Pull on the filter tub to **ASSURE** the male docking plug is **SEATED** in the female bulkhead socket.

2. Place the amount of **FILTER AGENT** into the fryer vat as prescribed in the cleaning manual provided by your chemical supplier; thoroughly stir the filter agent into the shortening using a skimmer; then skim the shortening to remove any floating crumbs.

**CAUTION:** **PRIOR TO PROCEEDING TO THE NEXT STEP, PUT ON SAFETY GOGGLES, NEOPRENE INSULATED GLOVES AND AN APRON.**

3. Carefully attach the drain valve handle to the drain valve; then open the drain valve by turning the **DRAIN VALVE HANDLE** slightly downward. When the bottom of the filter tub is covered with about two (2) inches of shortening, completely **OPEN** the drain valve, and while shortening is draining, scrape all sides of the vat to remove encrusted material using the scraper.
4. When all shortening has drained into the filter tub, use the **DRAIN ROD** to stand the wire rack on one side of the vat.
5. Use the drain rod to pull the sediment on the bottom of the vat towards the valve opening, then use the rod to push sediment through the valve opening.

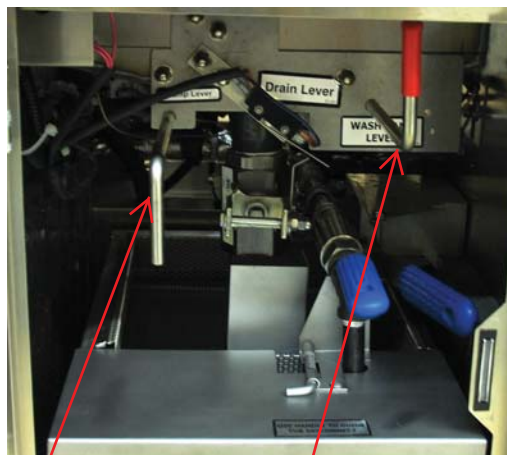

Vat Shortening Return

Top Shortening Return

**CAUTION:** **DO NOT ACTIVATE (TURN) THE VAT SHORTENING RETURN LEVER AND TOPSIDE SHORTENING LEVER AT THE SAME TIME! TO DO SO WILL REDUCE SHORTENING FLOW.**

6. If there is **NO** sediment or debris visible on the heat elements or bottom of the vat, **CLOSE** the drain valve; then turn the **LEFT HAND Vat Shortening Return Lever**  $\frac{1}{4}$  **turn counter clockwise** to automatically return shortening in the filter tub through the **SWEEP NOZZLE** in the bottom of the vat. When all shortening has been returned to the vat, turn the **LEFT HAND Vat Shortening Return Lever**  $\frac{1}{4}$  **turn clockwise** to stop the flow of shortening; then proceed to paragraph B page 30.
7. If there is considerable sediment and debris on the bottom of the vat, **FLUSH** this sediment from the vat using the **Wash Down Hose** or **OPTIONAL Automatic Vat Cleaner (AVC)** also referred to as **SPRAY BLASTER**, as described below.
  - a. Fryer **WITHOUT** an Automatic Vat Cleaner (AVC) <Spray Blaster>
    - 1) Leave the drain valve in the **OPEN** position, **CAREFULLY** connect the **Wash Down Hose Male In-Line Plug** to the **TOPSIDE FEMALE SOCKET**; then place the **Wash Down Hose nozzle** into the vat and hold it firmly against an inner wall so it will not recoil upward when the pump comes on.
    - 2) Turn the **RIGHT HAND Topside Shortening Return Lever**  $\frac{1}{4}$  **turn counter clockwise** and hold the hose nozzle at a **45°** angle from the bottom of the vat causing sediment and debris to bounce off the rear wall and flow towards the drain valve.
    - 3) Use the **"L" shaped brush** to push the sediment through the drain valve to keep the drain clear. Hose off the **Heat Elements** and vat walls until all sediment and debris has been flushed through the drain into the filter tub.

- 4) Turn the RIGHT HAND Topside Shortening Return Lever  $\frac{1}{4}$  turn clockwise ; then CAREFULLY remove the Wash Down Hose MALE In-Line Plug from the TOPSIDE FEMALE SOCKET by depressing the Topside Socket Release Knob.
- 5) Hang the Wash Down Hose in an up-right position so shortening can drain into a metal container; then proceed to paragraph B page 30.

b. Fryer WITH an Automatic Vat Cleaner (AVC). \*\* OPTIONAL \*\*

- 1) With the Drain Valve in the OPEN position, CAREFULLY place the AVC (Spray Blaster) on the fryer's TOPSIDE HANGER BRACKET and SECURELY connect the MALE In-Line Plug on the AVC flexible hose to the TOPSIDE FEMALE SOCKET.
- 2) Turn the RIGHT HAND Topside Shortening Return Lever  $\frac{1}{4}$  turn counter clockwise to allow shortening in the filter tub to be discharged into the vat through the four (4) nozzles in the bottom of the spray blaster, flushing sediment and debris through the drain valve. When all sediment and debris has been flushed from the vat, turn the Topside Shortening Return Lever  $\frac{1}{4}$  turn clockwise, remove the male in-line plug on the Spray Blaster from the Topside Female Socket by depressing the Topside Release Knob.
3. CAREFULLY remove the HOT Automatic Vat Cleaner from the hanger bracket, and THOROUGHLY clean it in a 3 compartment sink.
4. Proceed to paragraph B page 30.

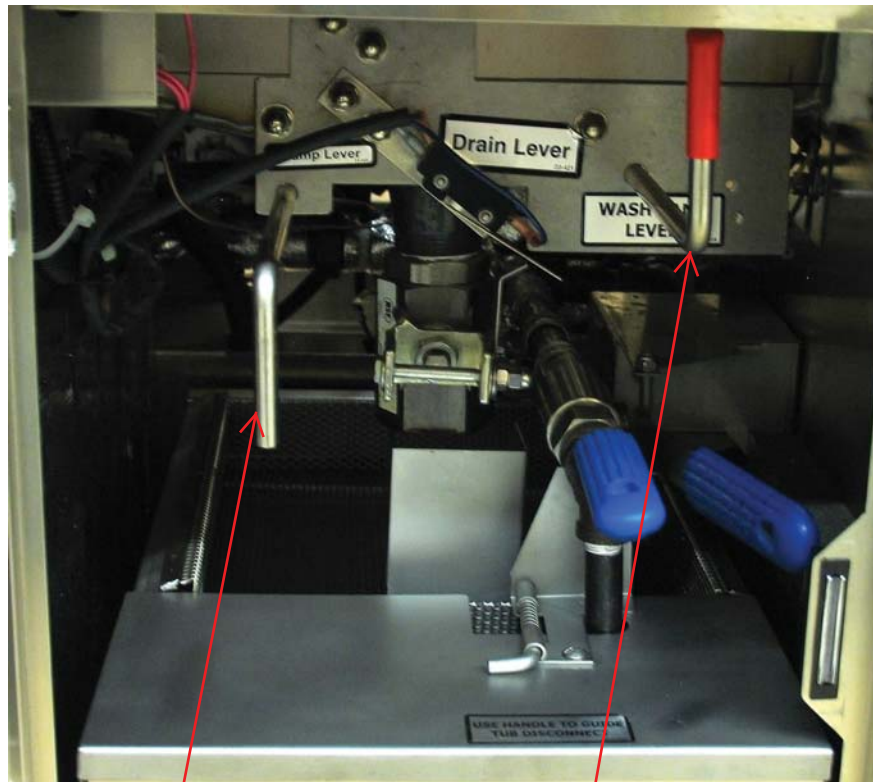

**Vat Shortening Return**

**Top Shortening Return**

## B. POLISHING SHORTENING

- 1 Set a timer for the amount of time established for POLISHING shortening, then turn the vat shortening RETURN LEVER 1/4 TURN COUNTER CLOCKWISE to allow shortening to circulate through the system and to POLISH the shortening.

CAUTION: DO NOT POLISH THE SHORTENING MORE THAN THE ESTABLISHED TIME AS IT WILL PUMP EXCESS AIR INTO THE SHORTENING CAUSING SHORTENING BREAKDOWN.

2. At the end of the established time, TURN the Vat Shortening RETURN LEVER 1/4 TURN CLOCKWISE, turn the DRAIN VALVE HANDLE to the closed UP position; replace the grill in the fryer; then TURN the Vat Shortening RETURN LEVER 1/4 COUNTER CLOCKWISE to automatically return shortening in the filter tub to the fryer vat.
3. When all shortening in the filter tub has been returned to the fryer, TURN the Vat Shortening RETURN LEVER, 1/4 TURN CLOCKWISE check and if necessary add fresh shortening so shortening is level with the middle line of the letter "E" in the word LEVEL of the shortening level mark on the rear wall of the fryer.
4. CAREFULLY remove the Filter Tub Assembly from the FEMALE Bulkhead Socket adjacent to the Drain Valve by depressing the DOCKING RELEASE HANDLE; then THOROUGHLY clean, assemble and replace the Filter Tub Assembly in the fryer cabinet.

## SHORTENING DISPOSAL, FRYER BOIL-OUT& SHORTENING INSTALLATION

A. GENERAL - Shortening should be BOILED-OUT every 7 DAYS to remove carbon buildup and other encrusted material.

### B. SHORTENING DISPOSAL

1. CAREFULLY assemble the Filter Tub assembly according to paragraph A page 22 and CAREFULLY install it in the fryer cabinet according to paragraph B2 page 24.

CAUTION: PRIOR TO PROCEEDING TO THE NEXT STEP, PUT ON SAFETY GOGGLES, NEOPRENE INSULATED GLOVES AND AN APRON.

2. Turn the Toggle ON/OFF switch OFF, and ensure the filter tub is properly DOCKED beneath the fryer drain valve.

NOTE: Pull on the filter tub to ASSURE the male docking plug is SEATED in the female bulkhead socket.

3. Attach the Drain Valve Handle to the drain valve; then open the drain valve by turning the DRAIN VALVE HANDLE slightly downward. When the bottom of the filter tub is covered with about two (2) inches of shortening, completely OPEN the drain valve, and while shortening is draining, scrape all sides of the vat to remove encrusted material using a scraper.
4. When all shortening has drained into the filter tub, use the DRAIN ROD to place the wire rack on one side of the vat.
5. Use the drain rod to pull sediment on the bottom of the vat towards the drain valve opening and push it through the valve opening.
6. Use one (1) of the following procedures to FLUSH sediment and debris from the fryer vat:
  - a. Fryer WITHOUT an Automatic Vat Cleaner:
    - 1) CAREFULLY connect the Wash Down Hose MALE In-Line Plug to the TOPSIDE FEMALE SOCKET and place the Wash Down Hose into the vat and hold it firmly against an inner wall so it will not "recoil" upward when the pump comes ON.
    - 2) TURN the Topside Shortening Return Lever 1/4 turn counter clockwise and hold the wand hose nozzle at a 45° angle from the bottom of the fryer causing sediment and debris to bounce off the rear wall of the vat and flow towards the drain valve.
    - 3) Use the "L" shaped vat brush to push the sediment through the drain valve to keep the drain clear. Hose off the burner tubes and all walls of the vat until all the sediment and residue at the bottom of the fryer has been flushed through the drain into the filter tub. Then turn the Topside Shortening Return Lever 1/4 turn clockwise.
  - b. Fryer WITH an Automatic Vat Cleaner (AVC): \*\* OPTIONAL \*\*
    - 1) CAREFULLY position the AVC (SPRAY BLASTER) on the fryer and SECURELY connect the MALE In-Line Plug on the Spray Blaster flexible hose to the TOPSIDE FEMALE SOCKET.
    - 2) TURN the Topside Shortening RETURN LEVER 1/4 TURN COUNTER CLOCKWISE to allow shortening in the filter tub to be discharged in the vat through the four (4) nozzles in the bottom of the Spray Blaster flushing sediment and debris through the drain valve.
    - 3) When all sediment and debris has been flushed from the vat, TURN the Topside Shortening RETURN LEVER 1/4 CLOCKWISE and CAREFULLY remove the HOT Spray Blaster by depressing the TOPSIDE SOCKET RELEASE KNOB; then THOROUGHLY clean the Spray Blaster in a 3 compartment sink.
    - 4) CAREFULLY connect the Wash Down Hose MALE In-Line Plug to the TOPSIDE FEMALE SOCKET, place the Wash Down Hose into the vat and hold it firmly against an inner wall so it will not "recoil" upward when the pump comes ON.

7. DISPOSE of the shortening in the filter tub as follows:
  - a. Restaurants NOT equipped with a Shortening Disposal System.
    - 1) Place the Wash Down Hose NOZZLE into a METAL container and hold it firmly against an inner wall.
    - 2) TURN the TOPSIDE SHORTENING RETURN LEVER 1/4 TURN COUNTER CLOCKWISE and pump shortening into the metal container.
    - 3) When all shortening has been pumped into the container, TURN the TOPSIDE SHORTENING RETURN LEVER 1/4 TURN CLOCKWISE, remove the Wash Down Hose from the TOPSIDE FEMALE SOCKET and hang the hose in an upright position so shortening in the hose can drain into a container.
  - b. Restaurants equipped with a Shortening Disposal System.
    - 1) SECURELY connect the Shortening Disposal Hose fitting to the TOPSIDE FEMALE SOCKET and connect the fitting on the other end of the hose to the Disposal System connector on the wall.
    - 2) TURN the TOPSIDE SHORTENING RETURN LEVER 1/4 TURN COUNTER CLOCKWISE and pump shortening in the filter tub into the Exterior rendering tank.
    - 3) When all shortening has been pumped into the rendering tank, TURN the TOPSIDE SHORTENING RETURN LEVER 1/4 TURN CLOCKWISE, remove the Disposal Hose from the TOPSIDE FEMALE SOCKET. Hang the hose in an upright position so shortening in the hose can drain into a container.
8. THOROUGHLY clean and re-assemble the filter tub.
- C. BOIL-OUT - Boil-out the fryer following the cleaning instructions in the Cleaning Manual provided by your approved chemical supplier. The following are generic procedures:

#### DTMR EQUIPPED FRYER

1. Ensure the Drain Valve Handle is in the closed (UP) position, then add water to the fryer vat until it reaches a point one (1) inch (25 mm) BELOW the middle line of the "E" in the word LEVEL on the rear wall of the fryer.
2. Add the amount of BOIL-OUT COMPOUND to the fryer vat as prescribed in the Cleaning Manual provided by the Chemical Supplier.
3. Turn the Toggle Switch for the fryer to the ON position, depress and release the START button; then depress and release the EXIT MELT button on the DTMR.
4. When the boil-out solution starts to BOIL set a timer for 30 minutes and frequently scrub the sides, front and back of the vat with a long handled scrub brush.

NOTE: If the boil-out solution starts to boil over, shut the fryer OFF for a few minutes and add water as necessary, then turn it back ON.

5. While the fryer is being BOILED OUT, clean the filter tub assembly according to procedures in the cleaning section.
6. When the timer sounds, turn the Toggle ON / OFF Switch for the fryer to the OFF position and CAREFULLY dispose of the boil-out solution in the fryer in a floor drain.
7. Use a scrubbing pad to remove carbon build-up from the top of the heat elements. To remove carbon build-up on the sides and bottom of the heat elements, slide one end of a stropping pad under each heat element, grasp that end with a pair of tongs and rock the pad up and down along the length of each heat element until all encrusted material has been removed. Replace the wire rack in the fryer.
8. Rinse the fryer with hot water until the water coming out of the drain valve is clear.
9. Mix a solution of ONE PART vinegar to 25 PARTS of water. Place this mixture into a one-gallon garden sprayer and THOROUGHLY spray this solution onto the SIDES, HEAT ELEMENTS and BOTTOM of the fryer to neutralize the Boil-Out Compound

NOTE: Boil-Out Compound will cause shortening to break down rapidly if it is not neutralized.

10. THOROUGHLY wipe the sides, heat elements and bottom of the fryer with clean, lint-free, dry towels to remove any remaining water, turn the DRAIN VALVE to the closed UP position; then fill the fryer with NEW shortening to the shortening level mark as described in paragraph D on the next page.

#### D. SHORTENING INSTALLATION

1. LIQUID SHORTENING: When using liquid shortening (cooking oil) fill the fryer with shortening even with the middle line of the "E" in the word LEVEL of the shortening level mark on the rear wall of the fryer.
2. SOLID SHORTENING:
  - a. Cut a block of solid shortening into small pieces.
  - b. Place small pieces of solid shortening EVENLY on top of the HEAT ELEMENTS or THOROUGHLY PACK these pieces of solid shortening between, below and above the HEAT ELEMENTS. While packing solid shortening is messy and time consuming, it is the safest and fastest way to melt solid shortening.
  - c. DTMR equipped Fryer
    - 1) Turn the fryer Toggle switch ON ; then place the Default-to-Manual-Restart (DTMR) Control in the SHORTENING MELT MODE by depressing then releasing the momentary START button on the DTMR. The RED START lamp and AMBER MELT MODE lamp will light to indicate the fryer is in the melt mode.
    - 2) When the HEAT ELEMENTS are COMPLETELY covered with LIQUID shortening and the shortening is heated, replace the grill in the fryer vat; then push the EXIT MELT button on the DTMR and proceed to paragraph d below.
  - d. Continue adding solid shortening as follows:
    - 1) Place small pieces of solid shortening into a fry basket.
    - 2) CAREFULLY lower the basket into the fryer vat.
    - 3) GENTLY turn the basket to allow these pieces of solid shortening to float away.
    - 4) Repeat the above steps until liquid shortening is even with the middle line of the "E" in the word LEVEL of the shortening level mark on the rear wall of the fryer vat.

WARNING!!!  
TO AVIOD INJURY

- I DO NOT MOVE A FRYER FILLED WITH HOT LIQUID.
- II ALWAYS WEAR OIL-PROOF, INSULATED GLOVES WHEN WORKING WITH A FRYER FILLED WITH HOT OIL.
- III ALWAYS DRAIN HOT OIL INTO A METAL TUB, POT OR CAN ... HOT OIL CAN MELT PLASTIC.

TECHNICAL ASSISTANCE - Contact an authorized service agent or the Customer Service Department, Ultrafryer Systems at 1-800-525-8130 for technical assistance.

A. ORDERING INFORMATION:

1. REPLACEMENT PARTS - Provide the following information when ordering replacement parts by phone, fax or mail:

Your company name and phone number

Your company purchase order number

Bill-to address

Ship-to address

Quantity desired

Part number and description of the desired-item

Your name or signature of authorized-buyer

Phone in order to: 1-800-545-9189 Ext 5029

FAX order to: 1-210-731-5099

Mail order to: Ultrafryer Systems

Order Entry Office

P.O. Box 5369

San Antonio, TX 78201

E-Mail your order to: Ultrafryerservice@ultrafryer.com

2. TERMS - Net 30 days for customers on approved accounts. Past due balances will be charged 1% per month (12% per annum) until full balance is paid.
3. DAMAGES - Ultrafryer Systems is not responsible for damage occurring in transit. All deliveries must be inspected for damage to shipping containers prior to departure of the delivering carrier. Any damage must be notated on the receiving document to facilitate filing of freight claims. Carriers must be notified immediately and freight inspections must be requested from the carrier. Ultrafryer Systems can and will gladly assist you in preparing and processing of the necessary claims only if proper notification has been accomplished on the carrier delivery document. Damaged equipment and or containers must be available for the claims inspector to inspect.
4. RETURNS - Ultrafryer Systems cannot guarantee credit for items returned without proper authorization. All returns must have prior Ultrafryer Systems Customer Service or Warranty department approval. An assigned number will be issued by the approval authority. Please print the assigned number on all returned packages and corresponding paperwork. Returned goods are subject to a 15% restocking charge. Ultrafryer Systems is not responsible for freight charges on returned goods unless authorized by Customer Service and or Warranty personnel. Ultrafryer Systems does not receive freight collect or C.O.D. shipments.

- B. PARTS IDENTIFICATION - Locate the part on the following sketches and note the index number i.e, 3, 6, etc; then obtain the part number and description for that index number on the page facing the sketches. Use that part number when ordering a replacement part.

ULTRAFRYER MODEL EUHE  
14" ELECTRIC FRYER

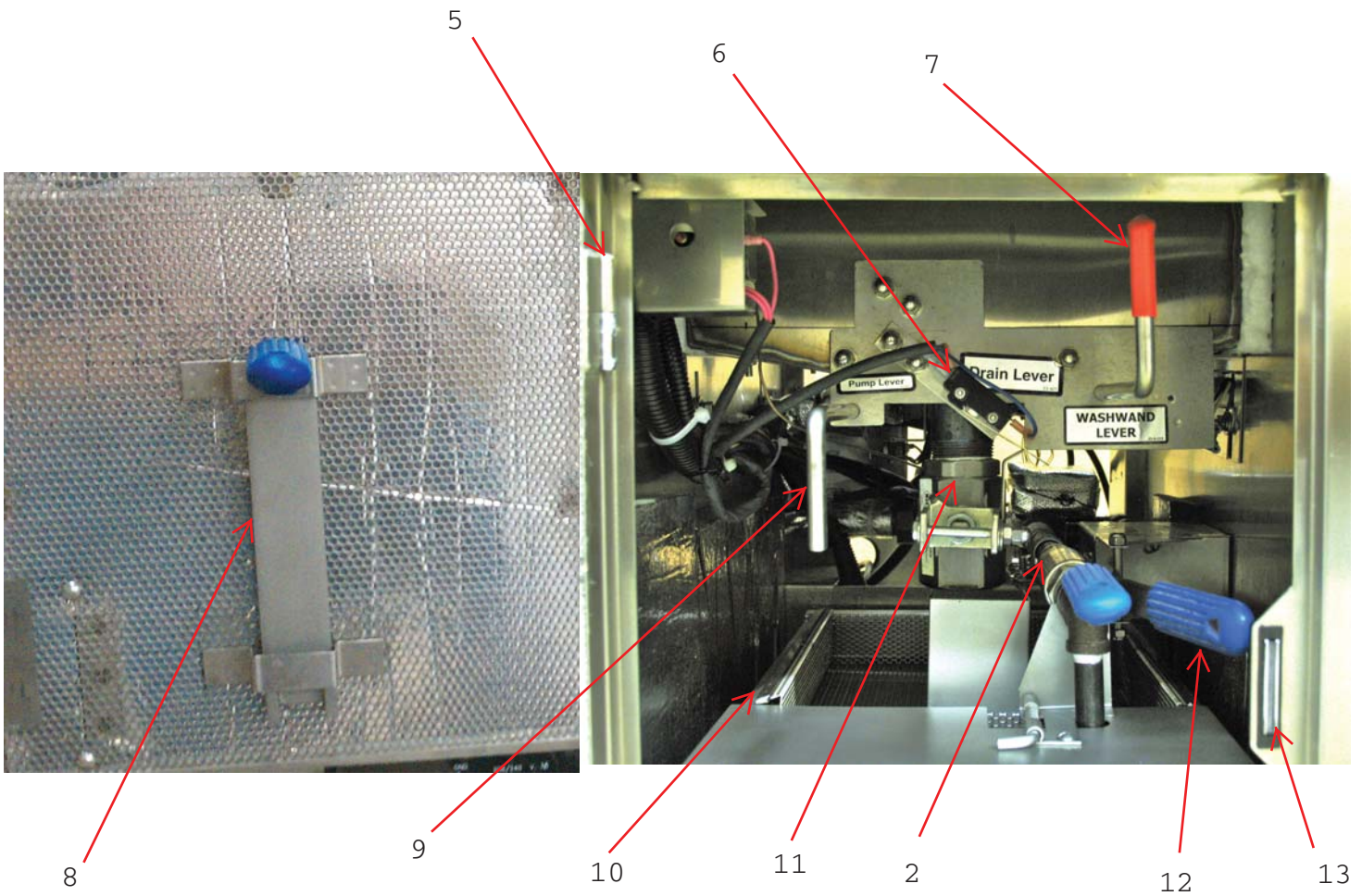
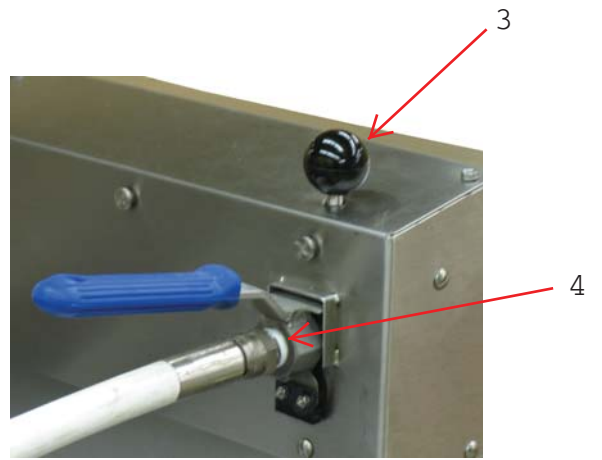
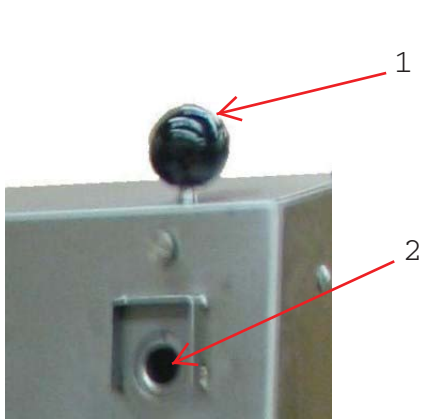



EUHE HARD DOCK FILTER TUB ASSEMBLY  
 14" With Micromesh Filter PN 12B299

ITEM	DESCRIPTION	PN
* 1	Filter Tub Scraper	12567
2	Micromesh s/s Filter Screen Assembly with StandPipe & Docking Assembly	12B113
3	Wash Down Hose Assembly	12B115
4	Filter Tub cover with hinge latch and Proximity sensor actuator for 14" Filter Tub	19B309
* 5	Proximity Actuator Sensor	18A059
6	18" Model Filter Tub	19B309
7	18" Model Crumb Catcher Screen	19B308
8	RH S/S Hinge Latch	22479
9	Medium Duty Caster	28A005

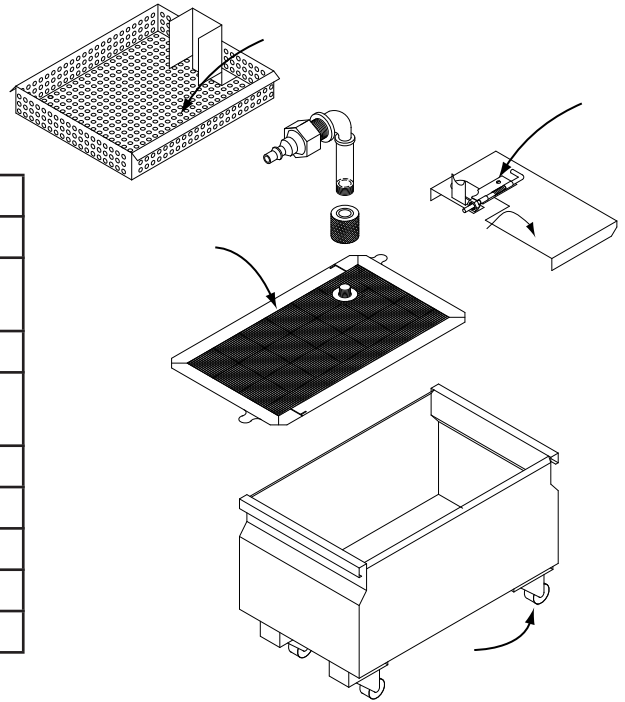

\* NOT SHOWN

WASH DOWN HOSE ASSEMBLY  
 PN 12B115

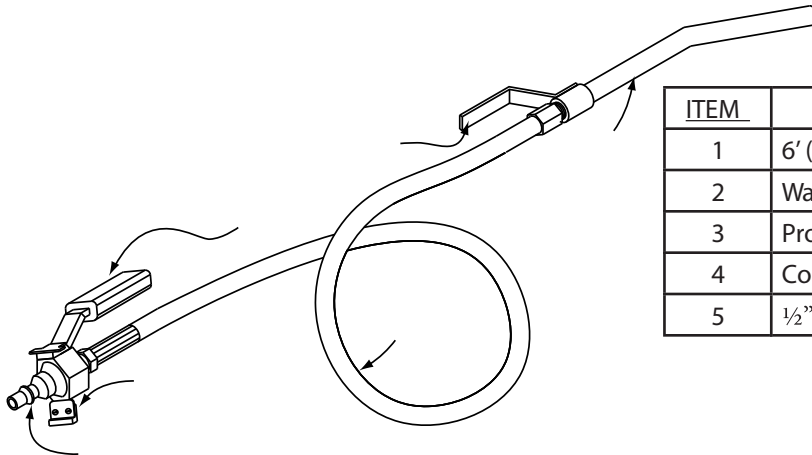

ITEM	DESCRIPTION	PN
1	6' (1829mm) Wash Down Hose w/Fittings	12541
2	Wash Down Hose & Nozzle Assembly	12675
3	Proximity Sensor Actuator	18A059
4	Cool II Handle	22734
5	1/2" (13mm) S/S Locking Seal Inline Plug	24A208

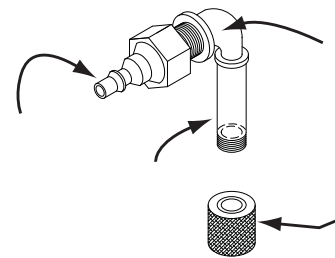

ITEM	DESCRIPTION	PN
1	Micro-Mesh S/S Filter Screen	21A278
2	1/2" (13mm) x 1" (25mm) 90° Black Iron Elbow	24A201
3	Top Compression Cap (Knurl Knob)	24369
4	1/2" (13mm) x 7" (178mm) Black Iron Nipple	24471
5	1/2" (13mm) S/S Locking Seal Inline Plug	24A208

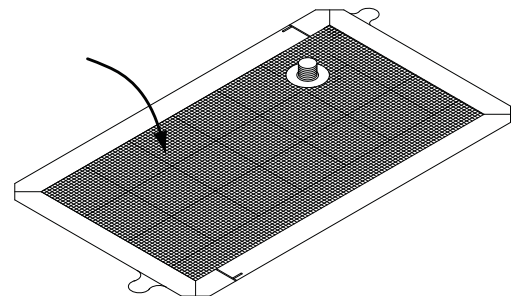

MICRO-MESH FILTER ASSEMBLY  
 WITH STANDPIPE & DOCKING ASSEMBLY  
 PN 12B113

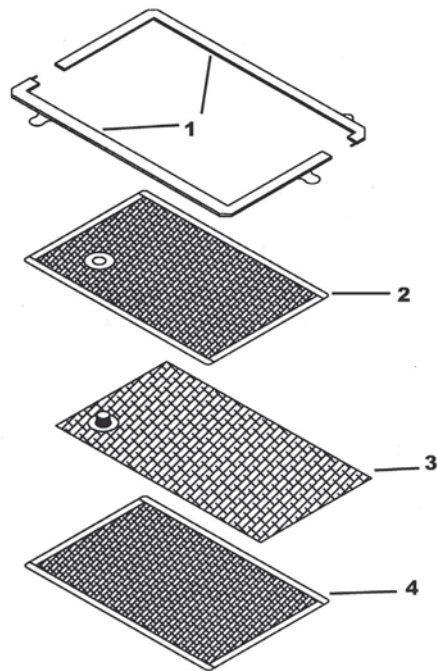

FILTER SCREEN ASSEMBLY		
<u>ITEM</u>	<u>DESCRIPTION</u>	<u>PN</u>
1	Replacement Frame Set	21A284
2	Replacement "Upper" Screen	21A285
3	Replacement Baffle Assembly	21A286
4	Replacement "Lower" Screen	21A287