



ULTRAFRYER[®] SYSTEMS



MODEL FM99 PORTABLE FILTER MACHINE OPERATING INSTRUCTIONS



WARNING!!! TO ASSURE PRODUCING A QUALITY PRODUCT WHILE PROLONGING THE LIFE EXPECTANCY OF THE FRYER, ENSURE FILTERING, BOIL-OUT AND CLEANING INSTRUCTIONS ARE STRICTLY ADHERED TO.

302 Spencer Lane • P.O. Box 5369

San Antonio, Texas 78201

(800) 525-8130 • (210) 731-5000 • Fax: (210) 731-5099

PREFACE

This manual was written and published by the Customer Service Department, Ultrafryer Systems, for use by store employees who will operate and maintain the Ultrafryer Systems Model FM 99 Portable Filter Machine. Proper use of this manual will allow store employees to properly operate, clean and maintain this filter machine which will reduce service call expenses.

CUSTOMER SERVICE DEPARTMENT
ULTRAFRYER SYSTEMS
302 SPENCER LANE
San Antonio, TX 78201

TABLE OF CONTENTS

	PAGE
GENERAL INFORMATION	
ULTRAFRYER ® LIMITED WARRANTY	2
SAFETY	3
DESCRIPTION/SPECIFICATIONS	4
FILTER MACHINE INITIAL CLEANING AND ASSEMBLY	
FILTER MACHINE DISASSEMBLY	6
FILTER MACHINE ASSEMBLY	7
PREVENTIVE MAINTENANCE, TROUBLESHOOTING AND CLEANING	
PREVENTIVE MAINTENANCE	9
TROUBLE SHOOTING	9
CLEANING DAILY	10
CLEANING WEEKLY	12
PORTABLE FILTER MACHINE OPERATION	
FILTERING SHORTENING	14
FRYER BOIL-OUT	15
SERVICE AND PARTS	
TECHNICAL ASSISTANCE	17
ORDERING INFORMATION	17
PARTS IDENTIFICATION	17

GENERAL INFORMATION

Ultrafryer Systems, INC. Portable Filter Machine Warranty

Ultrafryer Systems, INC. warrants to the original purchaser of the PORTABLE FILTER MACHINE sold **within** the United States, it's territories and Canada, that **the machine** will be free of defects in material and workmanship for the period listed below:

PARTS WARRANTY – Parts are covered for a period of one (1) year from the initial start up date. Ultrafryer Systems, INC. reserves the right to charge for certain parts that exceed the price of \$100.00 until the defective part is returned to Ultrafryer Systems, INC., attention WARRANTY DEPARTMENT. After inspection, a determination **will be made whether** the claims the result of defect in materials or workmanship. **If the defect is the result of neglect or abuse** credit will not be issued. All parts are to be shipped back **PREPAID BY THE CUSTOMER**.

FILTER HOSES – **FILTER HOSES ARE COVERED FOR 90 DAYS from the initial start up date.**

INSTANT POLISH PAD – (Magnesol) **This component part is proprietary to the O.E.m. and therefore Ultrafryer Systems, INC. does not warranty any part of the filter pad system that come with a PORTABLE FILTER MACHINE.**

PROCESSING WARRANTY CLAIMS – The equipment owner must promptly notify Ultrafryer Systems, INC. Warranty Department of any alleged defects by calling 800-525-8130. After such notice, the Warranty Department will perform its obligation under this warranty within a commercially reasonable period of time. If alleged defects develop after normal business hours, on weekends, or holidays the owner must call the Warranty Department at the above number. This number is monitored 24 hours a day and 7 days a week. Ultrafryer Systems, INC. will notify an AUTHORIZED service agent to make repairs during normal working hours and if necessary, after normal working hours. **Payment for** any repairs done without AUTHORIZATION from Ultrafryer Systems, INC. Warranty Department **may become the responsibility of the owner of the equipment.**

NON WARRANTY COVERAGE – This warranty does not include coverage for any consequential cost of damages including, but not limited to, any loss in store sales, spoiled food products, transportation, duty or custom cost. This does not cover original installation and adjustments such as leveling and electrical connections. This warranty does not cover travel over 100 miles or 2 hours drive time from the location of the PORTABLE FILTER MACHINE, or overtime or unauthorized repairs or installation, damage in shipment, and normal maintenance. This warranty does not cover the cost to UNCLOG FILTER LINES, CLEAN THE FILTER SCREEN, **or repair any unit used for purposes other than to pump LIQUID SHORTENING from the tub to the fryer vats.** Ultrafryer Systems, INC. reserves the right to void any component warranty on the PORTABLE FILTER MACHINE that is stored for more than 6 (six) months after shipment from Ultrafryer Systems, INC and not put into service.

LABOR COVERAGE- The cost for labor to replace parts or service the PORTABLE FILTER MACHINE is covered for a period of 1 (one) year from the initial start up date. The Warranty Department must be promptly notified prior to summoning of any service organization during the first year of operation.

DISCLAIMER OF WARRANTY

Other than as stated herein Ultrafryer Systems, INC. makes no warranty of any kind, express or implied, including but not limited to any warranty merchantability of fitness for a particular purpose, including trade usage. Ultrafryer Systems, INC. sole obligation, and purchaser's sole remedy, under this warranty is repair or replacement, at the discretion of Ultrafryer Systems, INC. of any part or component that proves to be defective in materials or workmanship. In no event shall Ultrafryer Systems, INC. be liable for consequential, incidental, or special loss or damages arising from the use of, or inability to use, the PORTABLE FILTER MACHINE. There are no other documents or oral statements for which Ultrafryer Systems, INC. will be responsible.

SAFETY

The major safety hazard associated with the Ultrafryer Systems Model FM 99 Portable Filter Machine is burns from **HOT** shortening. In order to prevent serious burns, good housekeeping habits are required. The floor in front of and the area around the fryer should be kept clean and dry. The Filter Machine operates on 120 Volt electrical power. To prevent serious electrical shock or death **ALWAYS** disconnect electrical power **PRIOR** to disassembly / assembly or cleaning of a Filter Machine. In addition to the above, follow the Safety Precautions listed below:

1. Always use extreme **CAUTION** when working around **HOT** shortening.
2. **NEVER** move a Filter Machine filled with **HOT** shortening.
3. **OSHA** Regulations require oil-proof insulated gloves, safety goggles, and an apron be worn when operating the Filter Machine.
4. **NEVER** point the Return Hose Nozzle anywhere other than the inside of a Fryer vat or shortening disposal container while operating the Filter Machine.
5. **DO NOT** attempt to move a Filter Machine by pulling on the **ELECTRICAL CORD** or **RETURN HOSE**.
6. **ALWAYS** ensure that the Return Hose connection is **SECURE** before operating a Filter Machine.
7. **DO NOT** turn the Filter Pump Motor **ON** unless the Return Hose Nozzle **HAS BEEN** inserted in a fryer vat or disposal container.
8. **DO** check the Return Hose for **CRACKS, KINKS, BULGES, or SOFT SPOTS** prior to operating a Filter Machine.
9. **NEVER** attempt to repair a defective Return Hose. A replacement Return Hose with **SECURE** fittings is available from Ultrafryer Systems through normal supply channels.
10. **ALWAYS** ensure that the Filter Pump motor switch is in the **OFF** position when resetting the motor overload switch.
11. **ALWAYS** store hoses upright, hanging from one end, to prevent congealed shortening from forming inside the hose.

DESCRIPTION / SPECIFICATIONS

DESCRIPTION

The Model FM99 Portable Shortening Filter Machine is constructed from 16 & 18 gauge, type 304 polished satin finish stainless steel, and is manufactured to National Sanitation Foundation standards. The major assemblies of the Model FM99 Portable Filter Machine are; 1) Filter Tub w/casters for mobility; 2) Filter Screen and Standpipe Assembly; 3) Suction Line and Wash Down Hose Assembly; 4) Pump and Motor Assembly; and 5) Crumb Catcher Pan and Sludge Screen and Pan. The customer has the option to order the standard Stainless Steel Micro-Mesh Filter Screen or a Magnepad Filter Assembly that uses a Magnesol Impregnated filter pad. This Portable Filter Machine can be easily disassembled, cleaned and reassembled without the use of tools.

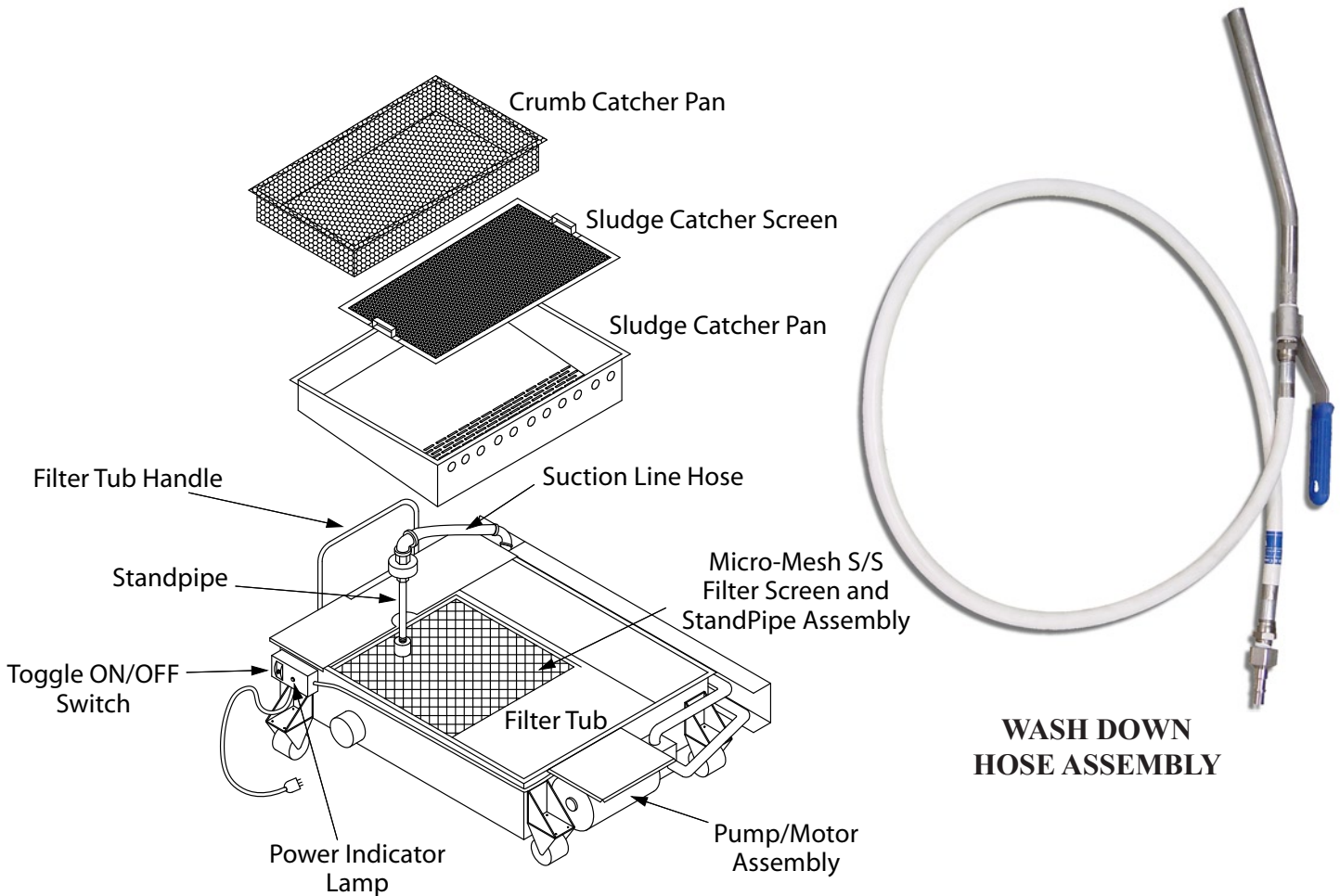

MODEL FM 99 FILTER MACHINE PN 11B319

SPECIFICATION

Shortening Capacity	99 lbs (44.9kg)	Overall Width	20”(508 mm)
Overall Depth	30” (762 mm)	Overall Height w/o Handle	6” (152 mm)
Electrical Supply	120 Volt 6.6 Amps 1 Phase 60 Hz		

This Filter Machine is designed to be used with a single, Electric or Gas, front drain fryer with a shortening capacity of 99 lbs (44.9 kg) or less.

FILTER MACHINE
INITIAL CLEANING AND ASSEMBLY

INITIAL CLEANING

The Ultrafryer Systems Model FM 99 Portable is wiped clean with solvents at the factory to remove any visible signs of dirt, oil, grease, etc., remaining from the manufacturing process; then given a light coat of oil. Each Filter machine, and its components, should be THOROUGHLY washed with HOT sanitizing solution to remove film, dust or debris and wiped dry prior to placing the filter machine in operation.

A. FILTER MACHINE DISASSEMBLY

1. Disassemble the Filter Machine by removing the major components in the following sequence; CRUMB CATCHER PAN, SLUDGE CATCHER PAN AND SCREEN, FILTER TUB HANDLE, COVER, WASH DOWN HOSE, and FILTER ASSEMBLY.

NOTE :The “standard” Model FM 99 Portable Filter Machine is equipped with a Micro-Mesh Stainless Steel Filter Screen and Standpipe Assembly. Since customers have the same option to select the Magnepad Filter and Standpipe Assembly, both filter assemblies will be covered within this manual.

2. THOROUGHLY clean all components EXCEPT the Filter Assembly with HOT sanitizing solution and allow those items to air dry.

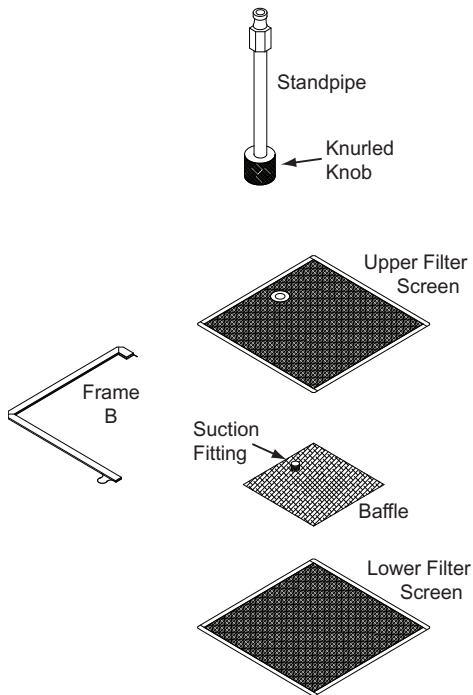

a. “Micro-Mesh” Stainless Steel Filter Screen

- 1) Remove the **STANDPIPE** from the **FILTER SCREEN** assembly, grasp the **FINGER LOOP** on **FRAME A** and adjacent **FINGER LOOP** on **FRAME B**, **EVENLY** pull the frames apart; then **HINGE FRAME A** to remove it from the **FILTER SCREENS FIRST**.
- 2) Grasp the **FINGER LOOP** on the straight side of **FRAME B**; then **HINGE** it to remove **FRAME B** from the **FILTER SCREENS**.
- 3) Separate the **UPPER FILTER SCREEN** and **BAFFLE** from the **LOWER FILTER SCREEN**.
- 4) **CAREFULLY** clean the two frames, screens and baffle in the 3 compartment sink with hot water and allow these items to air dry. **DO NOT USE SOAP**. If necessary the channels in each frame can be cleaned with the edge of a scotch-brite pad.
- 5) Insert the **SUCTION FITTING** on the **BAFFLE** in the hole of the **UPPER FILTER SCREEN**; then place these items on top of the **LOWER FILTER SCREEN**.
- 6) **ENSURE** all sides of the **FILTER SCREEN** assembly are aligned, place the **PIN** end of **FRAME A** on the **FILTER SCREENS**, place the **CHANNEL** on the frame adjacent to the **PIN** end over the **FILTER SCREENS**; then **HINGE** the frame so the edge of the **FILTER SCREENS** are inserted in the other **CHANNEL** of **FRAME A**.
- 7) Place the **PIN** end of **FRAME B** on the **FILTER SCREENS** so the **PIN** is seated in the **CHANNEL** of **FRAME A** near the **FINGER LOOP**, place the **CHANNEL** on the frame adjacent to the **PIN** end over the edge of the **FILTER SCREENS**; then **HINGE** the frame so the edge of the **FILTER SCREENS** are inserted in the other **CHANNEL** of **FRAME B** and the **PIN** of **FRAME A** is seated in the **CHANNEL** of **FRAME B**.
- 8) Adjust **FRAME A** and **B** so both **PINS** are properly seated in the **CHANNEL** of the opposite frame; then **CAREFULLY** connect the **KNURL KNOB** on the **STANDPIPE** to the **SUCTION FITTING** on the **FILTER SCREEN** assembly. **DO NOT OVERTIGHTEN!**

b. “Magnepad Envelope” Filter

- 1) Remove and discard the Filter Pad Envelope, **CAREFULLY** clean the Baffle Assembly and Clip/ Standpipe Assembly in the 3 compartment sink with **HOT** water and allow these items to air dry. **DO NOT USE SOAP!!** Reassemble the Magnepad Envelope Filter using a **NEW** Filter Pad Envelope as follows:
 - a) Insert the **BAFFLE** into the **FILTER PAD ENVELOPE**, when inserted properly the **SUCTION FITTING** will protrude through the hole in the pad.
 - b) Fold the **FLAP** over (in the direction of the hole), securing the Baffle inside the **FILTER PAD ENVELOPE**.
 - c) **CAREFULLY**, align the **CLIP & STANDPIPE ASSEMBLY** so that the **CLIP** can secure the **FLAP** on the Envelope and the **STANDPIPE** will align over the **SUCTION FITTING** protruding through the Envelope.

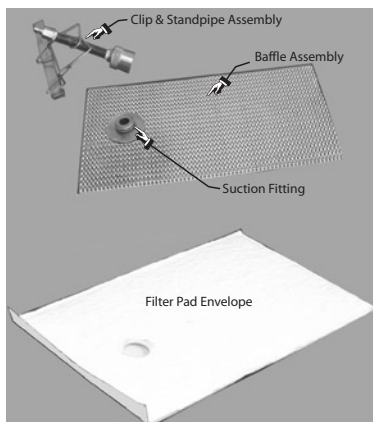

- d) Tighten the Knurled **NUT** on the **STANDPIPE** on the **SUCTION FITTING** protruding through the Envelope.

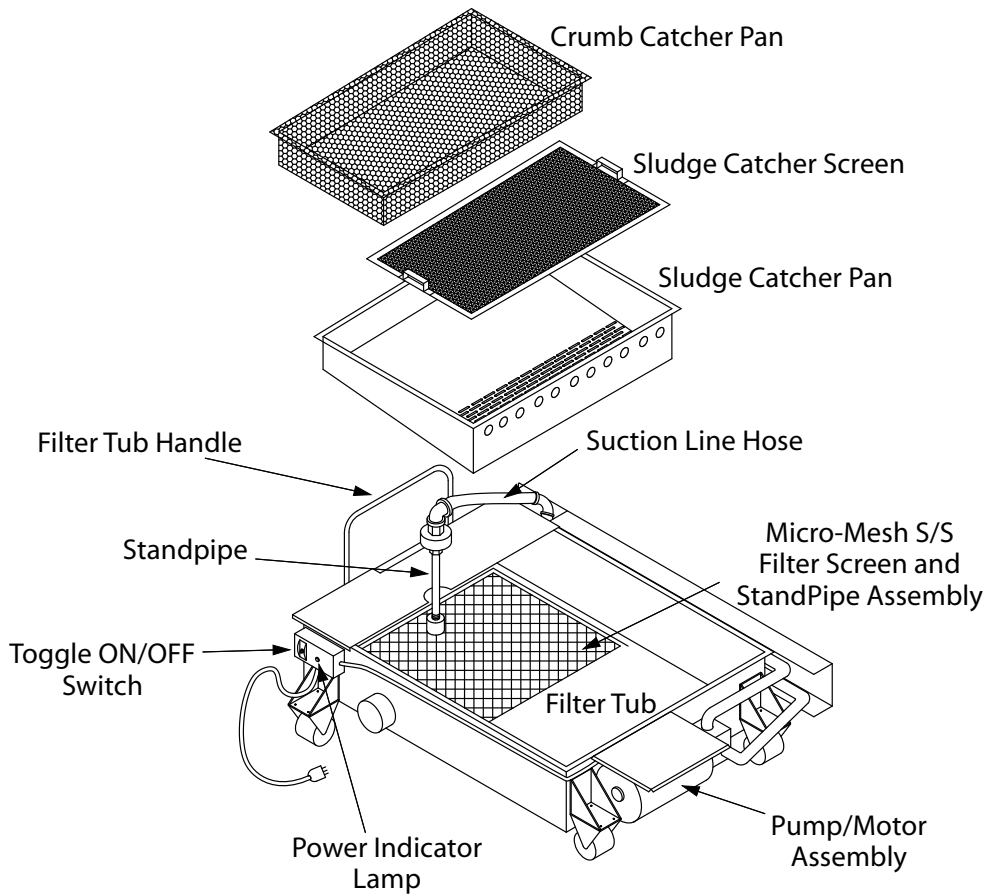

**MODEL FM 99 PORTABLE FILTER MACHINE
PN 11B319**

B. FILTER MACHINE ASSEMBLY

1. Reassemble the Filter Machine by replacing the components in the following sequence;
 - 1) **FILTER ASSEMBLY**, 2) **SLUDGE CATCHER SCREEN, AND PAN**, 3) **CRUMB CATCHER PAN**, 4) **COVER**, 5) **FILTER TUB HANDLE**.
 - a. **CAREFULLY** insert the Filter Assembly in the bottom of the Filter Tub with the **STANDPIPE** centered in the handle end of the tub.

CAUTION: WHEN ASSEMBLED, ENSURE THERE ARE NO FINGER LOOPS ON THE STANDPIPE SIDE OF THE FILTER.
 - b. **CAREFULLY** insert the Sludge Catcher Screen and Pan, and the Crumb Catcher Pan in the Filter Tub.
 - c. Place the Filter Tub **COVER** on the Filter Tub so that the **STANDPIPE** is **CENTERED** in the **SLOT** in the cover; then connect the Female Quick-Connect fitting on the **SUCTION LINE HOSE** to the Male stem on the **STANDPIPE ASSEMBLY**.
 - d. Install the **HANDLE** on the Filter Tub; then temporarily place the Wash Down Hose assembly in the Filter Tub pending use of the Filter Machine.
 - e. When ready to use the Portable Filter Machine, **SECURLEY** insert the male plug on the Washdown Hose to the Female Locking Seal Socket located adjacent to the Suction Line Hose.

PREVENTIVE MAINTENANCE, TROUBLESHOOTING AND CLEANING

PREVENTIVE MAINTENANCE

Minimal maintenance is required on a Portable Filter Machine because of its design and materials used in its manufacture. However, some preventive maintenance and inspection must be performed periodically to prevent break downs which could curtail food sales. Any preventive maintenance or inspection should be accomplished with CAUTION while the Filter Machine is in operation since HOT liquid shortening could cause severe burns. If service or repair is required, electrical power MUST BE TURNED OFF PRIOR TO performing that service or repair.

PREVENTIVE MAINTENANCE SCHEDULE

<u>ITEM</u>	<u>DAILY</u>	<u>INSPECT FOR:</u>
Hoses		Inspect the Suction Line and Wash Down Hoses for any evidence of deterioration or damage.
 <u>WEEKLY</u> 		
Connectors		Inspect the Suction Line and Wash Down Hose Quick-Connect Fittings for wear or damage
Electrical Cord and Switch		Inspect the Filter Pump/Motor Electrical Cord and Toggle ON/OFF Switch for any evidence of deterioration or damage.

TROUBLESHOOTING

- A. GENERAL: The problems and possible solutions listed in the troubleshooting chart below are typical Problems that are frequently encountered. ONLY qualified repairmen are to use the troubleshooting chart to repair this Filter Machine.
- B. TROUBLESHOOTING CHART: Should a problem occur that cannot be easily corrected, contact an authorized repairman and/or Ultrafryer Systems Customer Service at 1-800-525-8130.

TROUBLESHOOTING CHART	
<u>PROBLEMS</u>	<u>POSSIBLE SOLUTIONS</u>
A The filter pump motor fails to operate when the Motor Toggle ON/OFF switch is placed in the ON position.	1 Check the manual reset button on the filter pump motor. WARNING!!! TURN THE FILTER PUMP ON/OFF SWITCH TO THE OFF POSITION PRIOR TO DEPRESSING THE RESET BUTTON. FAILURE TO TURN THE SWITCH OFF COULD RESULT IN SEVERE BURNS FROM HOT COOKING OIL! 2 If the filter pump motor fails to operate after the reset button has been depressed, repair or replace the motor.
B Decreased shortening flow rate while filtering.	1 Check for excessive sediment on the filter screen, standpipe suction fitting or in filter tub.
C Pump / Motor operates but does not pump shortening.	1 Check for congealed shortening in the shortening system. 2 Check that the Standpipe is seated on the baffle fitting. 3 Check for loose Standpipe / Suction Line Coupler connection.
D Pump / Motor hums but will not pump shortening.	1 Check for congealed shortening in the pump or in shortening plumbing.

CLEANING

Any item of equipment operates better and lasts longer when it is kept clean and properly maintained, and the Portable Filter Machine is no exception. In order for a Portable Machine to provide years of trouble-free service, it should be CLEANED and MAINTAINED DAILY and WEEKLY according to the following instructions or those provided by your operations department.

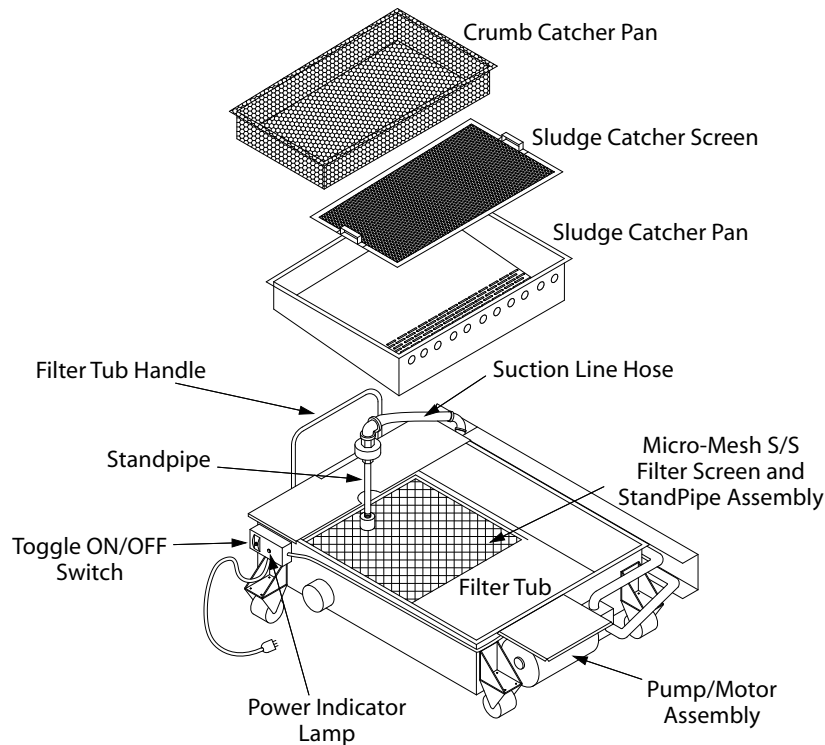

MODEL FM99 PORTABLE FILTER MACHINE

A. Daily

1. Clean the Filter Machine and Filter Assembly after FILTERING and AT CLOSING as follows:

a. After Filtering Shortening:

- 1) Disassemble the Filter Machine by removing the following items in the order listed; (1) CRUMB CATCHER PAN, SLUDGE CATCHER PAN and SCREEN, (2) FILTER TUB HANDLE, (3) COVER, (4) WASH DOWN HOSE, and (5) FILTER ASSEMBLY.
- 2) Clean the Suction Line Hose and Wash Down Hose with sanitizer solution; then hang the Wash Down Hose in an upright position so any shortening can drain into a container.
- 3) Discard crumb fragments in the Crumb Catcher Pan and THOROUGHLY clean the pan with HOT water and let it air dry.
- 4) Remove sludge from the Sludge Catcher Screen and Pan using a scraper and THOROUGHLY clean these items with HOT water and allow them to air dry.
- 5) Raise the Filter Assembly above the Filter Tub and let any sediment or shortening drain into the tub; then THOROUGHLY clean the filter assembly as follows:

a) "Micro-Mesh" Stainless Steel Filter Screen

- (1) CAREFULLY remove any debris from the screen using a scraper.
- (2) Remove the STANDPIPE from the FILTER SCREEN assembly, grasp the FINGER LOOP on FRAME A and adjacent FINGER LOOP on FRAME B, EVENLY pull the frames apart; then HINGE FRAME A to remove it from the FILTER SCREENS FIRST.
- (3) Grasp the FINGER LOOP on the straight side of FRAME B; then HINGE it to remove FRAME B from the FILTER SCREENS.
- (4) Separate the UPPER FILTER SCREEN and BAFFLE from the LOWER FILTER SCREEN.
- (5) CAREFULLY clean the two frames, screens and baffle in the 3 compartment sink with hot water and allow these items to air dry. **DO NOT USE SOAP.** If necessary the channels in each frame can be cleaned with the edge of a scotch-brite pad.
- (6) Insert the SUCTION FITTING on the BAFFLE in the hole of the UPPER FILTER SCREEN; then place these items on top of the LOWER FILTER SCREEN.

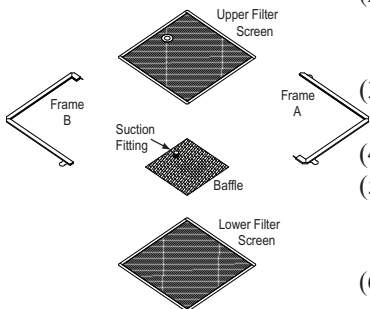
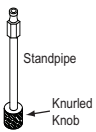

- (7) **ENSURE** all sides of the **FILTER SCREEN** assembly are aligned, place the **PIN** end of **FRAME A** on the **FILTER SCREENS**, place the **CHANNEL** on the frame adjacent to the **PIN** end over the **FILTER SCREENS**; then **HINGE** the frame so the edge of the **FILTER SCREENS** are inserted in the other **CHANNEL** of **FRAME A**.
- (8) Place the **PIN** end of **FRAME B** on the **FILTER SCREENS** so the **PIN** is seated in the **CHANNEL** of **FRAME A** near the **FINGER LOOP**, place the **CHANNEL** on the frame adjacent to the **PIN** end over the edge of the **FILTER SCREENS**; then **HINGE** the frame so the edge of the **FILTER SCREENS** are inserted in the other **CHANNEL** of **FRAME B** and the **PIN** of **FRAME A** is seated in the **CHANNEL** of **FRAME B**.
- (9) Adjust **FRAME A** and **B** so both **PINS** are properly seated in the **CHANNEL** of the opposite frame; then **CAREFULLY** connect the **KNURL KNOB** on the **STANDPIPE** to the **SUCTION FITTING** on the **FILTER SCREEN** assembly. **DO NOT OVERTIGHTEN!!!**

b) “Magnepad Paper Envelope” Filter - Magnepad Paper Filter Assemblies **DO NOT** have to be **SCRAPED** after filtering shortening.

- 6) Remove any sediment and shortening in the Filter Tub using a scraper; then wipe the tub dry with paper towels.
- 7) Carefully insert the Filter Assembly in the bottom of the Filter Tub with the **STANDPIPE** centered in the handle end of the tub. **WARNING: WHEN ASSEMBLED, ENSURE THERE ARE NO FINGER LOOPS ON THE STANDPIPE SIDE OF THE FILTER.**
- 8) **CAREFULLY** insert the Sludge Catcher Screen and Pan in the Filter Tub; then replace the Crumb Catcher Pan.
- 9) Place the **COVER** on the Filter Tub; then **SECURELY** connect the Female Quick-Connect fitting on the **SUCTION LINE HOSE** to the male stem on the **STANDPIPE ASSEMBLY**.
- 10) Install the **HANDLE** on the Filter Tub; then hang the **WASH DOWN HOSE** in an upright position so any shortening in the hose can drain into the container.
- 11) Place the Portable filter machine into its storage location.

b. At Closing

- 1) Repeat **DAILY** steps A 1 a 1) thru A 1 a 6) above.
- 2) **THOROUGHLY** clean the Filter Assembly as follows:
 - a) “Micro-Mesh” s/s Filter Screen:
 - (1) **THOROUGHLY** flush any remaining sediment from both sides of the filter screen with **HOT WATER**.
 - (2) Remove the **STANDPIPE** from the **FILTER SCREEN** assembly, grasp the **FINGER LOOP** on **FRAME A** and adjacent **FINGER LOOP** on **FRAME B**, **EVENLY** pull the frames apart; then **HINGE** **FRAME A** to remove it from the **FILTER SCREENS** **FIRST**.
 - (3) Grasp the **FINGER LOOP** on the straight side of **FRAME B**; then **HINGE** it to remove **FRAME B** from the **FILTER SCREENS**.
 - (4) Separate the **UPPER FILTER SCREEN** and **BAFFLE** from the **LOWER FILTER SCREEN**.
 - (5) **CAREFULLY** clean the two frames, screens and baffle in the 3 compartment sink with hot water and allow these items to air dry. **DO NOT USE SOAP**. If necessary the channels in each frame can be cleaned with the edge of a scotch-brite pad.
 - (6) Insert the **SUCTION FITTING** on the **BAFFLE** in the hole of the **UPPER FILTER SCREEN**; then place these items on top of the **LOWER FILTER SCREEN**.
 - (7) **ENSURE** all sides of the **FILTER SCREEN** assembly are aligned, place the **PIN** end of **FRAME A** on the **FILTER SCREENS**, place the **CHANNEL** on the frame adjacent to the **PIN** end over the **FILTER SCREENS**; then **HINGE** the frame so the edge of the **FILTER SCREENS** are inserted in the other **CHANNEL** of **FRAME A**.
 - (8) Place the **PIN** end of **FRAME B** on the **FILTER SCREENS** so the **PIN** is seated in the **CHANNEL** of **FRAME A** near the **FINGER LOOP**, place the **CHANNEL** on the frame adjacent to the **PIN** end over the edge of the **FILTER SCREENS**; then **HINGE** the frame so the edge of the **FILTER SCREENS** are inserted in the other **CHANNEL** of **FRAME B** and the **PIN** on **FRAME B** is seated in the **CHANNEL** of **FRAME A**.
 - (9) Adjust **FRAME A** and **B** so both **PINS** are properly seated in the **CHANNEL** of the opposite frame; then **CAREFULLY** connect the **KNURL KNOB** on the **STANDPIPE** to the **SUCTION FITTING** on the **FILTER SCREEN** assembly. **DO NOT OVERTIGHTEN!!!**

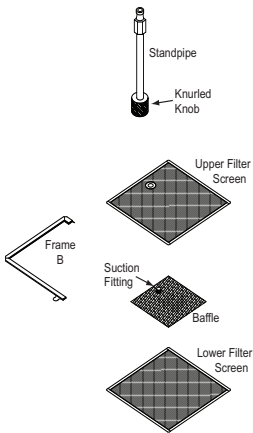

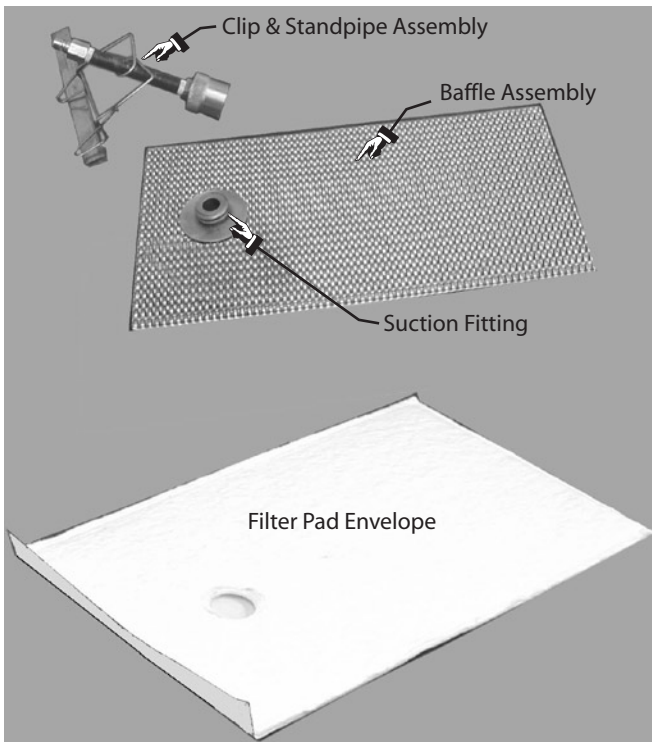

WARNING!!! TO AVOID ANY POSSIBILITY OF A SPONTANEOUS COMBUSTIBLE FIRE, WHICH HAS OCCURRED WITH THIS TYPE OF FILTRATION SYSTEM, THOROUGHLY CLEAN THE FILTER TUB ASSEMBLY PRIOR TO DEPARTING THE STORE AFTER CLOSING.

- b) “Magnepad” Envelope Filter - Remove and discard the **USED** Filter Pad Envelope, **CAREFULLY** clean the Baffle Assembly and Clip / Standpipe Assembly in the 3 compartment sink with **HOT** water and allow these items to air dry. **DO NOT USE SOAP!!** Reassemble the Magnepad Envelope Filter using a **NEW** Filter Pad Envelope as follows:
- (1) Insert the **BAFFLE** into the **FILTER PAD ENVELOPE**, when inserted properly the **SUCTION FITTING** will protrude through the hole in the pad.
 - (2) Fold the **FLAP** over (in the direction of the hole), securing the Baffle inside the **FILTER PAD ENVELOPE**.
 - (3) **CAREFULLY**, align the **CLIP & STANDPIPE ASSEMBLY** so that the **CLIP** can secure the **FLAP** on the Envelope and the **STANDPIPE** will align over the **SUCTION FITTING** protruding through the Envelope.
 - (4) Tighten the knurled **NUT** on the **STANDPIPE** to the **SUCTION FITTING** protruding through the Envelope.
 - (3) Repeat **DAILY** steps A1 a 6) through steps A1 a 11) above.

B. WEEKLY

1. Perform the daily cleaning steps A 1 a) 1) thru A 1 a) 6) above.
2. Place the **CRUMB CATCHER PAN** and **SLUDGE CATCHER SCREEN** in the fryer with the Boil-Out Solution for cleaning, and after they are cleaned, **ENSURE** they are sprayed with a solution of vinegar/water as described in **WEEKLY** step B3 a) 3) below.
3. Clean the Filter Assembly as follows:
 - a) “Micro-Mesh” stainless steel filter screen:
 - 1) Disassemble the filter screen according to **DAILY** steps A 1 a 5) a) (1) through A 1 a 5) a) (4) and clean the two (2) frames as described in step A 1 a 5) a) (5).
 - 2) Place the upper and lower **FILTER SCREENS** in the fryer with **BOIL-OUT SOLUTION** for cleaning. **DO NOT PLACE THE BAFFLE OR STANDPIPE IN THIS SOLUTION!!!** **BOIL-OUT** the fryer vat according to instructions contained in the cleaning manual provided by your chemical supplier.
 - 3) After the filter screens have been cleaned in the Boil-Out Solution, **ENSURE** they are **THOROUGHLY** sprayed with a solution of **1 PART** vinegar to **25 PARTS** of water to **NEUTRALIZE** the boil-out solution, then allow the screens to air dry. **NOTE:** any residue of boil-out solution on the filter screens could cause the rapid breakdown of the shortening.
 - 4) Reassemble the “Micro-Mesh stainless steel filter screen according to **DAILY** steps A 1 a 5) a) (6) through A 1 a 5) a) (9).
 - b) “Magnepad” Envelope Filter - Disassemble, clean, and re-assemble the “Magnepad” Filter Assembly according to **DAILY** cleaning steps A 1 b) 2) b) above.
4. **THOROUGHLY** clean the Filter Tub, Cover, and if applicable, Sludge Catcher Pan with **HOT SANITIZER SOLUTION** and allow them to air dry.
5. Re-assemble the Filter Tub according to **DAILY** steps A 1 a 7) through A 1 a 11) (pg 11).

WARNING: WHEN ASSEMBLED, ENSURE THERE ARE NO FINGER LOOPS ON THE STANDPIPE SIDE OF THE FILTER.

PORTABLE FILTER MACHINE OPERATION

FILTERING SHORTENING - Shortening should be filtered at least twice a day, once after the lunch rush and again after the dinner rush. When a Model FM99 Portable Filter Machine is used to filter shortening in multiple **SINGLE** fryers; the fryer used to cook French Fries should be filtered **FIRST** followed by fryers used to cook other products. Assemble a **CLEAN** Filter Machine according to **CLEANING** steps A1 a7), through A1 a11) page 11.

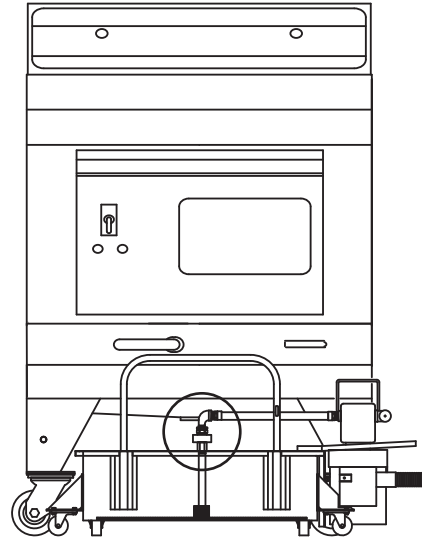

1. **CAREFULLY** position the Filter Machine beneath the fryer until the fryer's **DRAIN VALVE** is centered directly **ABOVE** the crumb Catcher Pan as shown.

CAUTION: BEFORE PROCEEDING TO THE NEXT STEP, PUT ON SAFETY GOGGLES, NEOPRENE INSULATED GLOVES AND AN APRON.

2. Separate the Wash Down Hose from the Female Locking Seal Coupling by depressing the **RELEASE** button; then open the drain valve **SLIGHTLY**. When the bottom of the tub is covered with about two (2) inches, completely **OPEN** the drain valve and while the shortening is draining, scrape all sides of the vat to remove encrusted material using the scraper.
3. When all shortening has drained into the filter tub, use a **DRAIN ROD** to stand the vat grill on one side of the vat, and to pull the sediment on the bottom of the vat towards the valve opening, then use the rod to push sediment through the valve opening.
4. Connect the electrical cord on the Pump/Motor assembly to an electrical receptacle; then **SECURELY** connect the **MALE** plug on the Wash Down Hose to the **FEMALE** Locking Seal Coupling adjacent to the Suction Line Hose.
5. **FIRMLY GRIP** the Washdown Hose and point the nozzle into the fryer vat. **DO NOT AIM THE NOZZLE OUTSIDE OF THE VAT AREA.** Turn the Toggle **ON/OFF** Switch on the pump/motor assembly to the **ON** position; then **CAREFULLY**, rinse the vat with the hose by holding the nozzle at a 45° angle to the bottom of the vat so shortening and debris will bounce off the rear wall and flow towards the drain opening.
6. Use a Drain Rod or a brush to push the sediment through the drain to keep the drain valve clear. Hose off the heat mechanism and walls of the vat until shortening and residue has been flushed through the drain and into the filter tub
7. After all debris and sediment has been flushed into the filter tub, turn the Toggle **ON/OFF** Switch on the motor to the **OFF** position, then replace the grill in the fryer vat.

NOTE: If the filter machine is equipped with a Magnepad Filter Assembly, proceed to **STEP 10**. If the filter machine is equipped with a Micro - Mesh Stainless Steel Filter Assembly, proceed to **STEP 8**.

8. Set a Timer for the amount of time established for **POLISHING** shortening, **FIRMLY** hold the Wash Down Hose Nozzle against an inner wall of the fryer; then turn the Pump/Motor Toggle **ON/OFF** Switch to the **ON** position to allow shortening to circulate through the Filter Machine **POLISHING** the shortening.
9. When the Timer sounds, turn the Pump/Motor Toggle **ON/OFF** Switch to the **OFF** position.

10. Place the **FRYER DRAIN VALVE** to the **CLOSED** position, hold the Wash Down Hose **NOZZLE** firmly against an inner wall of the fryer; then turn the Pump/Motor Toggle ON/OFF Switch to the **ON** position to return shortening in the Filter Tub to the Fryer.
11. When all shortening in the Filter Tub has been returned to the fryer, turn the Pump/Motor ON/OFF Switch to the **OFF** position, remove the Wash Down Hose Nozzle from the fryer; then remove the Filter Machine from the fryer.
12. Check and if necessary add fresh shortening to the fryer until shortening is at the proper level.
13. **THOROUGHLY** clean the Filter Machine according to **DAILY CLEANING** steps A1 a1) through A1 a11) on page 10, 11 and 12.
14. If applicable repeat step 1 through 13 to filter and polish shortening in another **SINGLE** fryer.

FRYER BOIL-OUT

1. Repeat Filtering Shortening steps 1 through 7 above; then turn the **DRAIN VALVE** to the **CLOSED** position.
2. **FIRMLY GRIP** the Wash Down Hose and **CAREFULLY** place the nozzle into a **METAL** shortening disposal container and hold it firmly against an inner wall.
3. Turn the Toggle ON/OFF Switch on the Pump/Motor to the **ON** position, and pump shortening in the Filter Tub into the container for disposal.
4. When **ALL** shortening has been pumped into the container, turn the Toggle ON/OFF Switch on the pump motor to the **OFF** position, remove the Wash Down Hose from the Female Locking Seal Coupling; then hang the hose in an upright position so shortening can drain into a metal container.

NOTE: Failure to hang the Wash Down Hose in an upright position to drain may cause the hose to become clogged with congealed shortening.

5. **THOROUGHLY** clean the Filter Machine according to **DAILY CLEANING** steps A1 a1) through A1 A11) on page 10, 11 and 12.
6. If applicable repeat step 1 through 5 above to dispose of used shortening in another **SINGLE** fryer.
7. **BOIL-OUT** each fryer using a **NON-CHLORINE BASED CLEANER** according to instructions in the fryer manual or manual provided by your Chemical supplier, dispose of the **BOIL-OUT SOLUTION** in a **FLOOR DRAIN**, **THOROUGHLY** rinse the vat interior to flush any remaining boil-out solution from the fryer; then **NEUTRALIZE** the boil-out solution by spraying the vat interior using a one gallon garden sprayer containing a solution of **ONE PART** vinegar to **25 PARTS** water.
6. Place **NEW** shortening into the vat, to the proper level according to instructions in the fryer manual.

CAUTION: DO NOT USE THE PUMP/MOTOR UNIT TO REMOVE WATER FROM THE FRYER, AS THIS WILL CAUSE PREMATURE FAILURE OF THE UNIT AND VOID THE WARRANTY.

SERVICE AND PARTS

TECHNICAL ASSISTANCE - Contact an authorized service agent or the Customer Service Department, Ultrafryer Systems at 1-800-525-8130 for technical assistance.

ORDERING INFORMATION:

- 1. REPLACEMENT PARTS** - Provide the following information when ordering replacement parts by phone, fax or mail:

Your company name and phone number

Your company purchase order number

Bill-to address

Ship-to address

Quantity desired

Part number and description of the desired-item

Your name or signature of authorized-buyer

Phone in order to: 1-800-545-9189 Ext 5029

FAX order to: 1-210-731-5099

Mail order to: Ultrafryer Systems

Order Entry Office

P.O. Box 5369

San Antonio, TX 78201

E-Mail your order to: JJROSAS@ULTRAFRYER.COM

- 2. TERMS** - Net 30 days for customers on approved accounts. Past due balances will be charged 1% per month (12% per annum) until full balance is paid.
- 3. DAMAGES** - Ultrafryer Systems is not responsible for damage occurring in transit. All deliveries must be inspected for damage to shipping containers prior to departure of the delivering carrier. Any damage must be notated on the receiving document to facilitate filing of freight claims. Carriers must be notified immediately and freight inspections must be requested from the carrier. Ultrafryer Systems can and will gladly assist you in preparing and processing of the necessary claims only if proper notification has been accomplished on the carrier delivery document. Damaged equipment and or containers must be available for the claims inspector to inspect.
- 4. RETURNS** - Ultrafryer Systems cannot guarantee credit for items returned without proper authorization. All returns must have prior Ultrafryer Systems Customer Service or Warranty department approval. An assigned number will be issued by the approval authority. Please print the assigned number on all returned packages and corresponding paperwork. Returned goods are subject to a 15% restocking charge. Ultrafryer Systems is not responsible for freight charges on returned goods unless authorized by Customer Service and or Warranty personnel. Ultrafryer Systems does not receive freight collect or C.O.D. shipments.

PARTS IDENTIFICATION - Locate the part on the following sketches and note the index number i.e, 1, 2, etc; then obtain the part number and description for that index number on the page facing the sketches. Use that part number when ordering a replacement part.

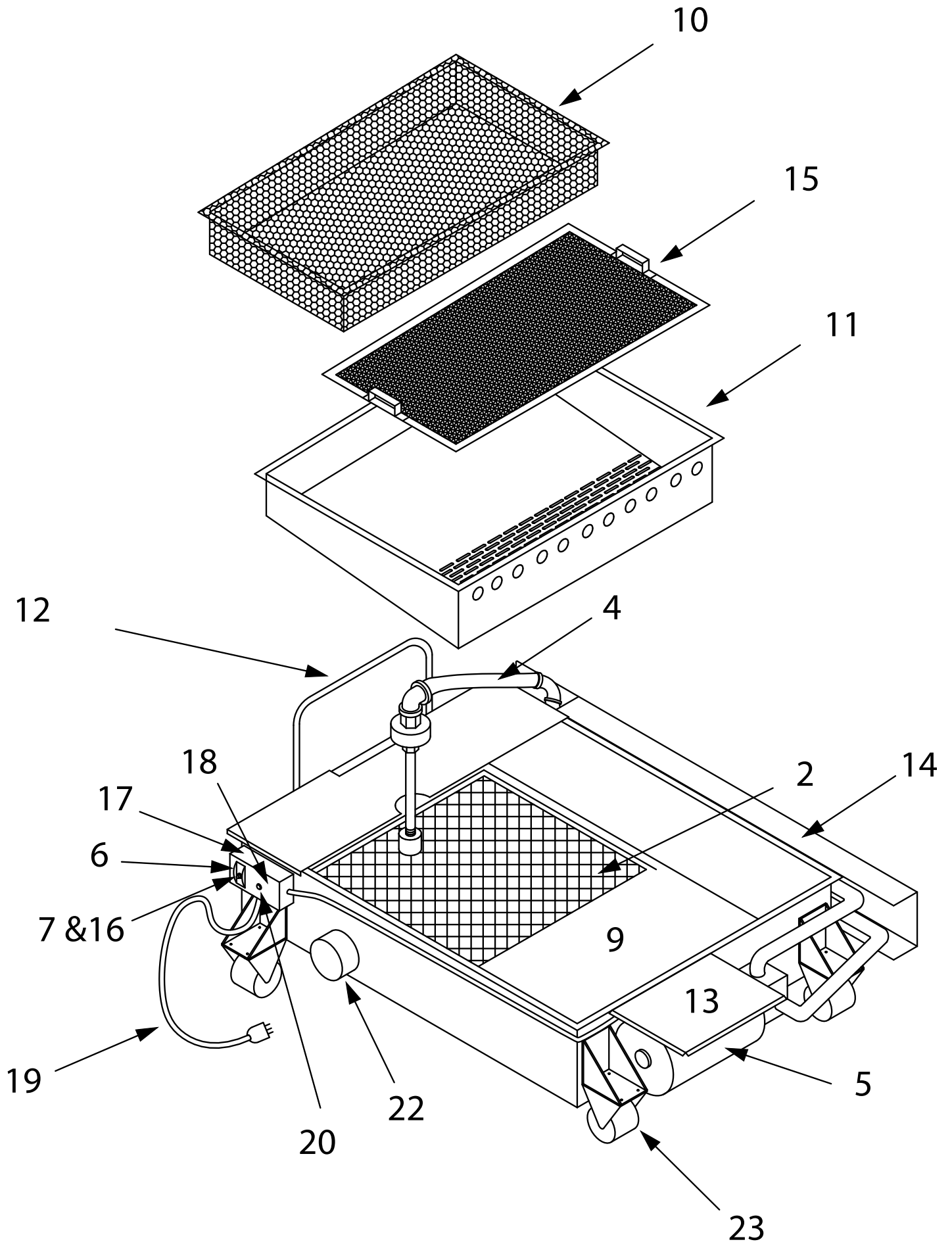

**MODEL FM99 PORTABLE FILTER MACHINE
PN 11B319**

<u>ITEM</u>	<u>DESCRIPTION</u>	<u>PN</u>
*1	Filter Tub Scraper	12567
2	Micro-Mesh s/s Filter Screen and Standpipe Assembly	12A807
*	Magnepad Filter Pan and Standpipe Assembly	12A814
*3	Wash Down Hose Assembly	12B396
4	Suction Line Assembly	12A276
5	Pump and Motor Assembly	12B359
6	Toggle On/Off Switch Guard	18129
7	SPST 15 Amp 125 Volt Toggle On/Off Switch	18204
8	Filter Tub Cover	19A924
9	Filter Tub Tank	19A926
10	Crumb Catcher Pan	19A927
11	Sludge Catcher Pan	19A928
12	Filter Tub Handle	19B244
13	Pump/Motor Assembly Cover	19B372
14	Inlet/Outlet Pump Plumbing Cover	19B373
15	Sludge Catcher Screen	21A299
16	Toggle On/Off Switch RED Protective Boot	22A104
17	2" x 4" (52mm x 104mm) Handy Box	23024
18	2" x 4" (52mm x 104mm) Handy Box Cover	23065
19	Type SJO 16/3 Electrical Cord w/Molded Plug 8 feet (2438mm) Long	23221
20	125 Volt 1/3 Watt Snaplight w/ RED Lens	23362
*21	1 1/4" (32mm) Boil-Out Drain Valve (Optional Item)	24A069
22	1 1/4" (32mm) Black Iron Pipe Cap	19B319
23	Medium Duty Caster	28A005

* NOT SHOWN



**REPLACEMENT SUCTION
LINE HOSE
PN 24A172**

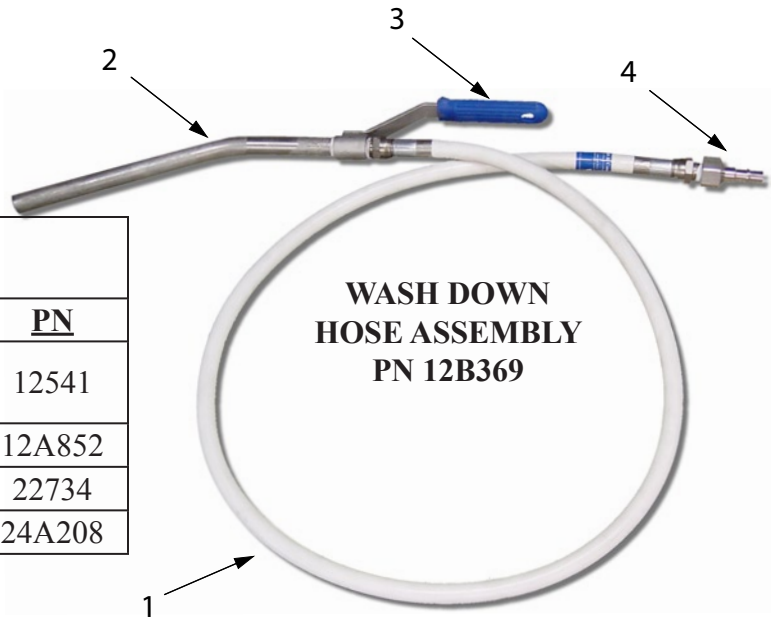

WASH DOWN HOSE ASSEMBLY PN 12B369		
ITEM	DESCRIPTION	PN
1	6 Foot (1829mm) Wash Down Hose W/ Fittings	12541
2	Wash Down Handle and Nozzle	12A852
3	Cool II Handle	22734
4	1/2"(13mm) Male S/S Locking Seal Plug	24A208

ILLUSTRATION NOT AVAILABLE

PUMP AND MOTOR ASSEMBLY PN12B359		
ITEM	DESCRIPTION	PN
1	3/8" (10mm) Quick-Connect Male Stem Fitting	22676
2	3/8" (10mm) x 1" (25mm) Black Iron Closed Nipple	24191
3	1/2" (13mm) x 90° Black Iron Street Elbow	24256
4	3/4" (19mm) x 1/2" (13mm) NPT Black Iron Hex Bushing	24257
5	3/4" (19mm) x 3/8" (10mm) NPT Black Iron Hex Bushing	24365
6	1/2" (13mm) NPT Male Quick-Connect Stem	24396
7	8 1/2" (215mm) Replacement Suction Line Hose	24A172
8	120 VOLT 60Hz 1725RPM 6.6 AMP Balder Pump and Motor Assembly rated at 7.7 GPM (29.26LPM). For motor only order PN 17A018 and for pump only order PN 24329.	24A206

**MICRO MESH FILTER SCREEN AND STANDPIPE ASSEMBLY
PN 12A807**

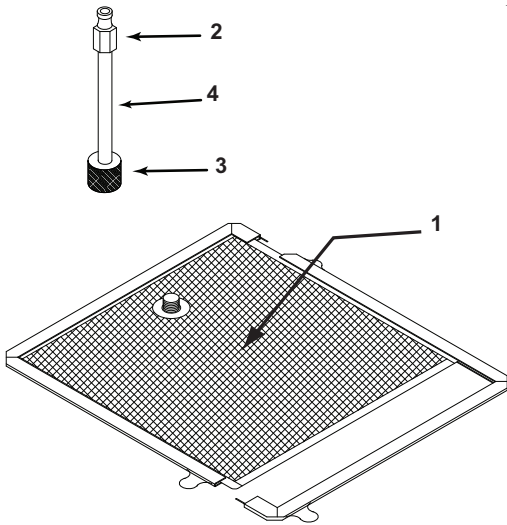

<u>INDEX NUMBER</u>	<u>DESCRIPTION</u>	<u>PN</u>
1	Micro Mesh Filter Screen (see exploded view)	21A279
2	3/8" (10 mm) NPT Male Stem Quick Connect Fitting	22-676
3	Top Compression Cap (Knurl Knob)	24-369
4	3/8" (10 mm) x 7" (178 mm) S/S Nipple	24-471

**NOTE: USED WITH FILTER TUB ASSEMBLY
PN 11A783.**

**EXPLODED
VIEW**

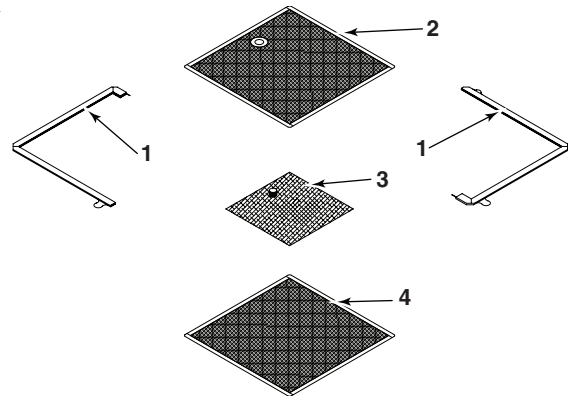

<u>INDEX NUMBER</u>	<u>DESCRIPTION</u>	<u>PN</u>
1	Filter Screen Frame Set	21A275
2	Upper Filter Screen	21A281
3	Baffle w/suction line fitting	21A282
4	Lower Filter Screen	21A274

**MAGNEPAD FILTER AND STANDPIPE
ASSEMBLY
PN 12A814**

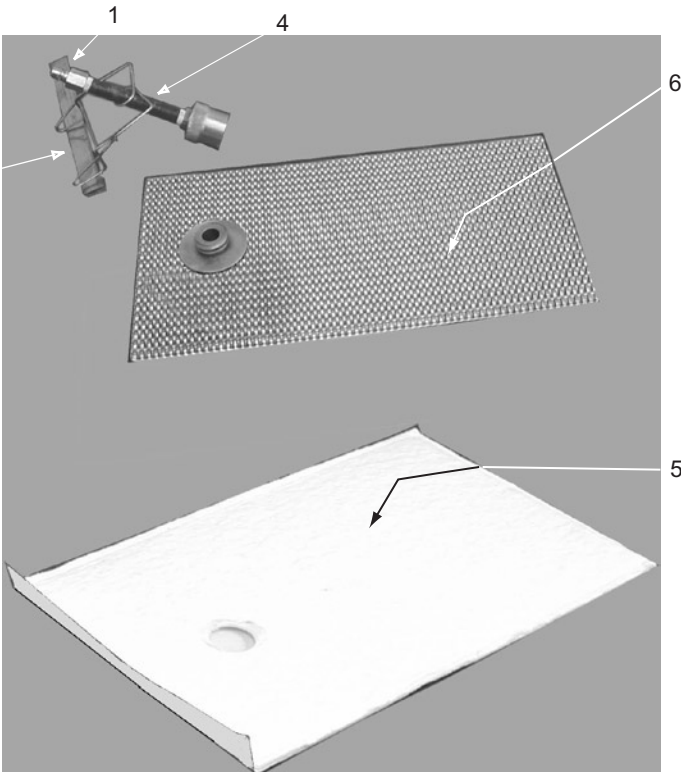

<u>ITEM</u>	<u>DESCRIPTION</u>	<u>PN</u>
1	3/8" (10mm) NPT Quick-Connect Male Stem Fitting	22-676
2	3/8" x 7" (10mm x 178mm) S/S Nipple	24-471
3	23 1/2" x 30 1/2" (597mm x 775mm) Baffle Kit consisting of items 4,5 & 6	29A056
4	Top Compression cap (Knurl Knob)	24A153
5	21 1/2" x 29" (546mm x 737mm) Baffle	29A050
6	23" (584mm) Long Standpipe Clip	29A051
7	23 1/2" (597mm) x 30" (762mm) Filter Pad	24A048
8	Case of 30 Filter Pads	29A054