



18" MODEL EUHE ELECTRIC FRYER WITH HARD DOCK FILTRATION



Operating Instructions

WARNING!! TO ASSURE PRODUCING A QUALITY PRODUCT WHILE PROLONGING THE LIFE EXPECTANCY OF THE FRYER, ENSURE FILTERING, BOIL-OUT AND CLEANING INSTRUCTIONS ARE STRICTLY ADHERED TO.

PREFACE

This Manual was written and published by the Engineering Department, Ultrafryer Systems for use by personnel who will operate a 18" Model EUHE Electric Fryer equipped with a Hard Dock Filtration System.

ENGINEERING DEPARTMENT
ULTRAFRYER SYSTEMS
302 SPENCER LANE
SAN ANTONIO, TX 78201

TABLE OF CONTENTS

GENERAL INFORMATION	PAGE
Warranty.....	6
Safety.....	7
Description / Specifications	7
Dimensions & Operational Requirements	7
Operating Controls	8
Automatic Safety Features	9
PRE-INSTALLATION	
General	9
Leveling.....	10
Electrical Connection	10
Clearances.....	11
Initial Cleaning	11
Default-To-Manual-Restart (DTMR)	11
Optional Controls	11
INITIAL START-UP	
Start-Up	13
Start-Up Procedures	13
Shortening Installation	14
Start-Up and Cooking.....	14
Cooking.....	17
OPERATING INSTRUCTIONS	
General	17
Filtering Shortening.....	17
Leveling Shortening.....	17
Boiling Out Fryer.....	17
Closing/Shutdown Instructions.....	17
CLEANING AND MAINTENANCE	
Cleaning	18
Maintenance.....	18
Electronic Thermostat Calibration	18
PREVENTITIVE MAINTENANCE AND TROUBLESHOOTING	
Preventative Maintenance.....	19
Troubleshooting	19
Troubleshooting Chart	19
CLEANING	
Daily	21
Weekly.....	24

TABLE OF CONTENTS.....Continued

OPERATION	PAGE
General	24
Default-To-Manual-Restart (DTMR) Control	24
DTMR Operation	25
Optional Controls	26
FILTER TUB ASSEMBLY AND INSTALLATION	
Filter Tub Assembly	27
Filter Tub Installation	27
FILTERING AND POLISHING SHORTENING	
Filtering Shortening.	28
Polishing Shortening.	30
SHORTENING DISPOSAL, BOIL-OUT AND SHORTENING INSTALLATION	
General	30
Shortening Disposal	30
Boil-Out	31
Shortening Installation	32
TECHNICAL ASSISTANCE & ORDERING INFORMATION	
Technical Assistance	33
Ordering Information	33
RECOMMENDED SPARE PARTS	xx
PARTS INFORMATION	xx
PartsInformation	xx
WIRING DIAGRAMS	42

GENERAL INFORMATION

ULTRAFRYER® LIMITED WARRANTY

Ultrafryer Systems warrants to the original purchaser of a gas or electric Ultrafryer® sold within the United States, its territories and Canada, that it will be free of defects in material and workmanship for the periods listed below:

STAINLESS STEEL FRYER VAT – Stainless Steel fryer vats are warranted for (10) ten years upon the terms hereinafter described. The (10) ten year warranty coverage applies ONLY to the Stainless Steel fryer vat and does not apply to the other components such as controls, fire boxes, gaskets, mounting hardware, or the heat shield weldment. The (10) ten year limited warranty coverage for the Stainless Steel fryer vats are as follows: (1) Vats that fail due to faulty workmanship or materials within the first twelve (12) months from the date of initial start up will be exchanged at no cost. Standard delivery ground freight will be prepaid by Ultrafryer Systems for first year failures only. The cost of labor to install the replacement vat will be covered by Ultrafryer Systems for vats, which fail within twelve (12) months from the date of initial start up. Labor for vat replacements after the first year is the responsibility of the owner.

(2) Vats that fail within the first (18) months will be exchanged at a cost not to exceed \$100.00 FOB San Antonio.

(3) Vats that fail within the first (24) months will be exchanged at a cost not to exceed \$150.00 FOB San Antonio. (4) Vats that fail within the next (8) years will be exchanged at a cost not to exceed \$200.00 FOB San Antonio. (Subject to inflation adjusted in accordance with the C.P.I.). Proper credit issue for vat failures is contingent upon receipt, by Ultrafryer Systems, of the serial number identification tag for any failed vat.

ULTRAFRYER PARTS – All parts on the Ultrafryer® are covered for a period of one (1) year from the initial date of start up. This is to include computers, gas valves, switches, thermostats, etc. Ultrafryer Systems reserves the right to charge for certain parts such as computers, filter pumps and motors or any item over the amount of \$100.00 until Ultrafryer Systems receives the defective part back. After inspection, credit for the part will be issued to the purchaser provided the part is deemed defective and that defect is not the result of neglect or abuse by the user. The shortening filtration system, (hoses) are warranted for ninety (90) days from the initial date of start up.

PROCESSING WARRANTY CLAIMS – The equipment owner must promptly notify Ultrafryer Systems Warranty Department of any alleged defects as soon as they are discovered by calling 1-800-525-8130. After such notice, the Warranty Department will perform its obligation under this warranty within a commercially reasonable period of time. If alleged defects develop after normal business hours, on weekends or on holidays the owner must call Ultrafryer Systems first at the above number. This number is monitored 24 hours a day, 7 days a week. Ultrafryer Systems will notify an authorized service agent to make repairs during normal hours or after hours. Any parts that need to be shipped back to Ultrafryer Systems will be shipped back prepaid by the customer marked with the processing number and to the attention of the WARRANTY DEPARTMENT.

NON WARRANTY COVERAGE – This warranty does not include coverage for any consequential cost of damages including, but not limited to, any loss in store sales, spoiled food products, transportation, duty or custom cost. This warranty does not cover the Ultrafryer® exported to countries outside the United States and its territories. This warranty does not cover original installation and adjustments such as leveling, calibrations, electrical and gas connections, or problems due to faulty or contaminated gas supply. This warranty does not cover travel over 100 miles or 2 hours driving time from the location of the Ultrafryer® or overtime or holiday charges unless the Warranty Department granted prior approval. This warranty does not cover damage due to misuse, abuse, alteration or accident. This Warranty does not cover improper or unauthorized repair or installation, damage in shipment, normal maintenance items such as gaskets, hoses, and exterior finishes. Ultrafryer Systems reserves the right to void component part warranty on any Ultrafryer® that is stored more than 6 (six) months after shipment from Ultrafryer Systems and not put into service.

LABOR COVERAGE – The cost for labor to replace parts are covered for one (1) year after the initial start up. This warranty will include the labor involved in the six (6) month and the twelve (12) month fryer inspections recommended by the manufacturer for the first year after initial start up. **The Warranty Department must be promptly notified of any defects within the first year of operation.** The labor warranty does not include the cost to repair or clear dirty filter systems or perform any adjustments that would normally fall under the tasks associated with a proper start up and/or demonstration. Labor is covered by Ultrafryer Systems for repairs by an AUTHORIZED service agent. Owner is responsible for all costs associated with fryer installation and start up unless prior arrangements have been made with Ultrafryer Systems.

DISCLAIMER OF WARRANTIES

Other than as stated herein ULTRAFRYER SYSTEMS makes no warranty of any kind, express or implied, including but not limited to any warranty of merchantability of fitness for a particular purpose, including trade usage. Ultrafryer Systems sole obligation, and purchaser's sole remedy, under this warranty is repair or replacement, at the discretion of Ultrafryer Systems, of any part or component that proves to be defective in materials or workmanship. In no event shall Ultrafryer Systems be liable for consequential, incidental, or special loss or damages arising from the use of, or inability to use, the ULTRAFRYER®. This limited warranty is the only and complete statement with respect to warranties of NEW Ultrafryer® PAR-2, PAR-3 Gas and Electric ULTRAFRYERS® sold after March 1st, 2001. There are no other documents or oral statements for which Ultrafryer Systems will be responsible.

B. SAFETY

The major safety concern associated with the Ultra Fryer Model EUHE Electric Fryer is burns from hot shortening. In order to prevent serious burns, good housekeeping habits are required. The floor in front of and the area around the fryer should be kept clean and dry. Whenever anything is placed in to a fryer vat, care should be used not to splash the hot shortening. Product should always be “**PLACED**” into the shortening, **NOT THROWN**. Safety goggles, neoprene insulated gloves and an apron must be worn while filtering or boiling-out a fryer vat. Electrical controls on this Fryer utilize 120, 208 or 240 volts single and three phase electrical power. Power is supplied from more than one circuit breaker and it should be determined that **ALL** electrical power has been removed prior to maintenance. The fryer should never be operated with wet hands or while standing in water. To do so can result in serious electrical shock or death.

C. DESCRIPTION / SPECIFICATIONS

The Ultra Fryer EUHE Electric fryer is constructed from 16 and 18 gauge type 304 polished satin finish stainless steel. The “standard” EUHE Electric fryer is equipped with a Default-To-Manual-Restart (DTMR) Control, however customers may request the fryer be equipped with an Ultrastat 11 Cooking Computer; an Ultrastat 21 Cooking Computer or an Ultrastat 25 Cooking Computer. In addition, each EUHE fryer is equipped with the NEWLY developed Hard Dock Filtration system that uses a stainless steel Filter Screen. The Customer has the option of ordering a Magnepad Filter Screen that uses a Magnesol impregnated Filter Pad in lieu of the stainless steel filter screen. The dimension specifications and electrical ratings are as follows:

D. ULTRAFRYER MODEL EUHE ELECTRIC FRYER DIMENSIONS & OPERATIONAL REQUIREMENTS

<u>SPECIFICATION ITEM</u>	18” EUHE ELECTRIC FRYER
Overall Width	19 1/2” (495 mm)
Overall Depth	37 1/2” (953 mm)
Work Height	36” (914 mm)
Oil Capacity	70 Lbs (35 Liters)
Size Vat Container	18” x 18” (457 x 457 mm)
Shipping Cube	17.9 FT ³ (.42 M ³)
Shipping Weight	265 lbs (119 kgs)
Electric Requirements	208/240 Volts 3 Phase 20 KW and 120 Volt Single Phase 6 Amps

NOTE:

TEST START-UP, OPERATIONS, COOKING, FILTERING, AND BOIL OUT PROCEDURES OF A 18” (457MM) MODEL EUHE ELECTRIC FRYER IN THIS MANUAL ARE BASED ON A DEFAULT-TO-MANUAL-RESTART (DTMR) CONTROL & ULTRASTAT 11 COOKING COMPUTER. REFER TO MANUAL PN 30A009, ULTRASTAT 21 COOKING COMPUTER OPERATION INSTRUCTIONS; OR MANUAL PN 30A051, ULTRASTAT 25 COOKING COMPUTER OPERATION INSTRUCTIONS TO PERFORM THESE FUNCTIONS ON AN EUHE ELECTRIC FRYER WITH A COOKING COMPUTER OTHER THAN THAT LISTED IN THIS MANUAL.

E. OPERATING CONTROLS LOCATION

18" MODEL EUHE ELECTRIC FRYER

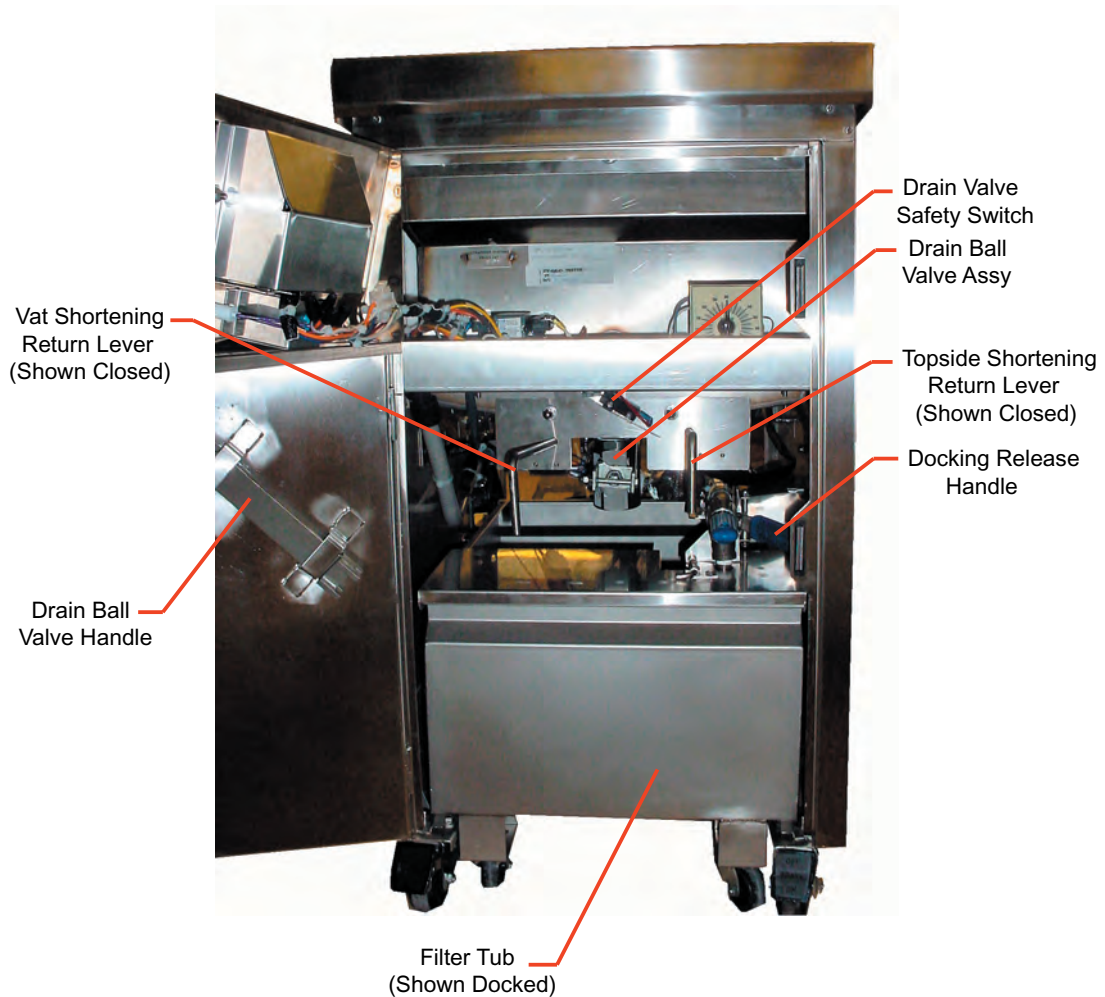
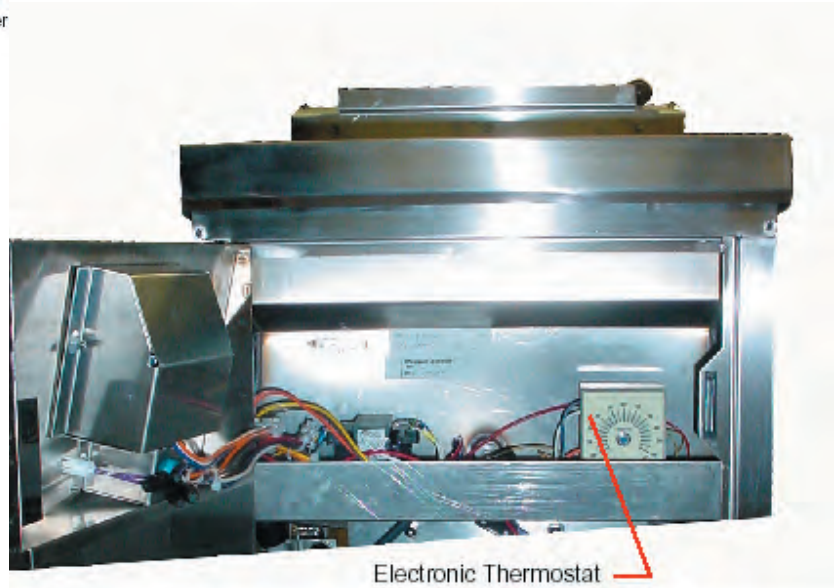
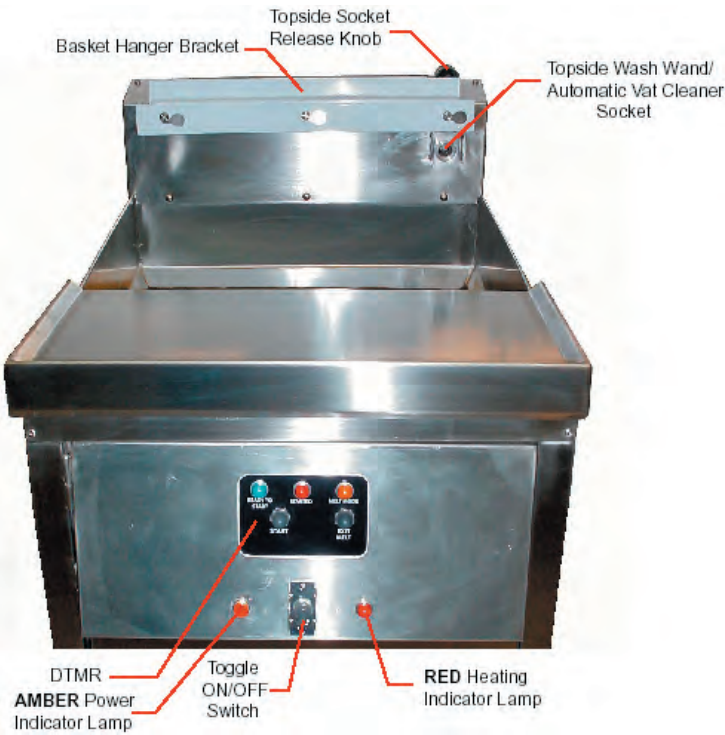

MODEL EUHE ELECTRIC FRYER

F. OPERATING CONTROLS:

The “standard” EUHE Electric fryer is equipped with a Default-To-Manual-Restart (DTMR) Control, however customers may request the fryer be equipped with an Ultrastat 11 Cooking Computer; an Ultrastat 21 Cooking Computer or an Ultrastat 25 Cooking Computer. When applicable, operating instructions for the Ultrastat Cooking Computer will be provided with the fryer. Operating controls on the standard EUHE electric fryer include: ON/OFF Toggle Switch, **AMBER** power indicator lamp, **RED** Heating indicator lamp and the applicable temperature controller. These controls are mounted on the temperature control access panel while the electronic thermostat and other fryer controls are located behind the access panel. These controls were identified in the illustrations shown on the previous page.



G. AUTOMATIC SAFETY FEATURES:

Each EUHE electric fryer has the following automatic safety features:

1. High limit thermostat to **SHUT OFF** electrical power to the fryer should shortening temperature exceed 450°F (232°C).
2. Drain valve safety switch in combination with the Default-To-Manual-Restart (DTMR) control that will **DISABLE** the fryer each time the drain valve is **OPENED**.
3. Shunt trip circuit breakers in the main electric panel that will automatically remove electric power to the fryer should a **FIRE** occur.
4. Fuses in each leg of the heat element high voltage circuit to **OPEN** that circuit should an element amperage **EXCEED** 35 Amps.

PRE-INSTALLATION:

Safe and satisfactory operation of an 18” Model EUHE electric fryer depends on it’s proper installation. Installation must conform to all national and local electrical codes, and in Canada, to their applicable national and local codes.

A. GENERAL:

Each model EUHE electric fryer should be installed as follows:

1. Placed beneath a properly designed exhaust hood.
2. Installed by a licensed electrician.

4. Restained by use of a restraining device to avoid splashing of hot liquid and to insure tension cannot be placed on electrical connections.

NOTE: ADEQUATE CLEARANCES MUST BE PROVIDED FOR SERVICING AND PROPER OPERATION.

B. LEVELING:

After the Ultrafryer electric fryer has been properly positioned in the store, it should be LEVELED using a spirite level by inserting the appropriate number of shim plates between each leg and caster plate. Leveling will assure that each vat contains the same amount of shortening when checked at the engraved shortening level mark on the rear wall of the fryer vat.

NOTE: A CASTER MAY NOT RETURN TO THE SAME POSITION AFTER BEING MOVED, WHICH REQUIRES A RE-LEVELING AFTER EACH MOVEMENT.

C. ELECTRICAL CONNECTION:

Each electrical fryer is wired internally to operate on 120 volt single phase and 208 or 240 volt 3 phase electrical power as shown on the fryer's rating plate and in the illustration below. The 120 volt control circuit of each fryer is internally wired to an eight (8) foot 120 volt electrical cord with a molded plug. The 208 or 240 volt 3 phase circuit of each fryer is internally wired to a SEPERATE terminal block which is to be used to connect to the building power source. It is ESSENTIAL that the 120 volt electrical receptacle is located within 8 feet of the fryer location and that provisions are made so that the fryer can be moved to service the fryer from the rear. Electrical connections to the fryer should be made by a liscensed electrcian and they must conform to the NATIONAL ELECTRIC CODE as well as to local electrical codes and/or ordinances. To avoid electrical hazards and insure proper operation of the electric fryer, the following precautions should be observed during installation:

1. MATCH VOLTAGE:

Before connecting electrical power, insure the line voltage matches the voltage rating on the fryer's rating plate.

2. CIRCUIT BREAKERS:

The fryer must be connected to a circuit having a shunt-trip circuit breaker sized in accordance with requirements of the National Electrical Code as well as local codes and ordinances.

3. ELECTRICAL CONNECTION;

It is ESSENTIAL that one of the LOW LEGS (120 volts to neutral) of the building's 208 or 240 volt power source, shown below, be connected to high voltage terminal L1 identified below, for proper operation of the 120 volt heat element indicator lamp.

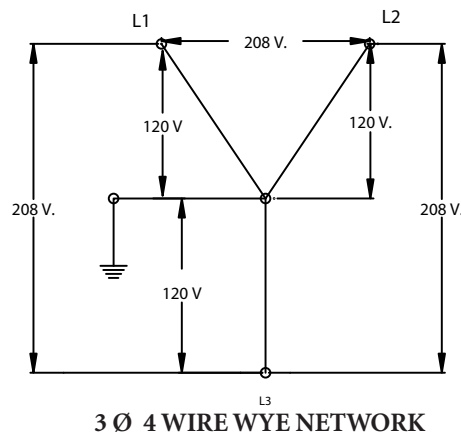
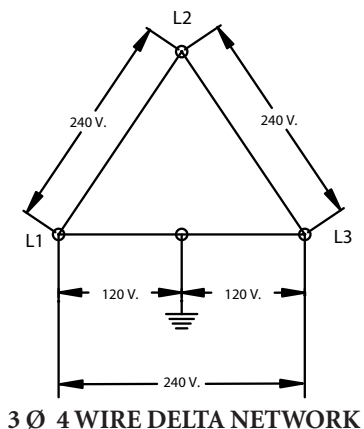

4. **GROUNDING:** The fryer **MUST** be grounded to the building ground system according to the National Electrical Code and local codes/ordinances.
 5. **FIRE PROTECTION:** The fryer should be installed beneath a powered exhaust hood which complies with NFPA96 standards and is equipped with an approved Fire Suppression System designed to automatically shut-off all sources of electrical power to the fryer in case of a vat fire.
- D. CLEARANCES** - The Model EUHE Electric Fryer **MUST** be kept free and clear of all combustibles. The **MINIMUM** clearances from combustible and non-combustible construction is 6” (152 mm) from the sides and 6” (152 mm) from the rear of the fryer. The fryer may be installed on combustible floors.
- E. INITIAL CLEANING**- New Electric Fryers are wiped clean with solvents at the factory to remove any visible signs of dirt, oil, grease, etc. remaining from the manufacturing process; then given a light coat of oil. Each fryer and filter tub assembly should be **THOROUGHLY** washed with **HOT** sanitizer solution to remove film residue, installation dust or debris and then wiped dry prior to placing the fryer into operation.
- F. DEFAULT-TO-MANUAL-RESTART (DTMR) CONTROL:** The Model EUHE electric fryer is equipped with a Default-to-Manual-Restart (DTMR) Control. This control contains a Default-to-Off electrical circuit that **DISABLES** a fryer any time the drain valve is **OPENED**, and a Default-to-Melt electrical circuit which automatically places a fryer in a shortening **MELT MODE** to gradually and **SAFELY** melt shortening each time a fryer is turned **ON** and the **START BUTTON** is depressed on the **DTMR** control. The Default-to-Manual-Restart Control is intended to avoid “operator errors” that can result in **DRY FIRING** a fryer causing shortening to be scorched, heat element damage and/or a vat fire.

DTMR CONTROL PANEL

BLUE READY TO START LAMP - When lit indicates that the power switch is in the ON position, the drain valve is **CLOSED**, and the fryer is ready to operate.

START BUTTON - When this button is momentarily depressed, it places the fryer in operation.

RED STARTED LAMP - When lit indicates that the **START BUTTON** has been momentarily depressed and the fryer is operating.

AMBER MELT MODE LAMP - When lit indicates that the **TIMER** in the Default-To-Melt circuit is cycling the fryer burner **ON** for four (4) seconds and **OFF** for 36 seconds to safely heat shortening.

EXIT MELT BUTTON - When this button is momentarily depressed the **TIMER** in the Default-To-Melt circuit will switch to the **FULL ON** position allowing the electronic thermostat to heat shortening to its pre-set temperature.

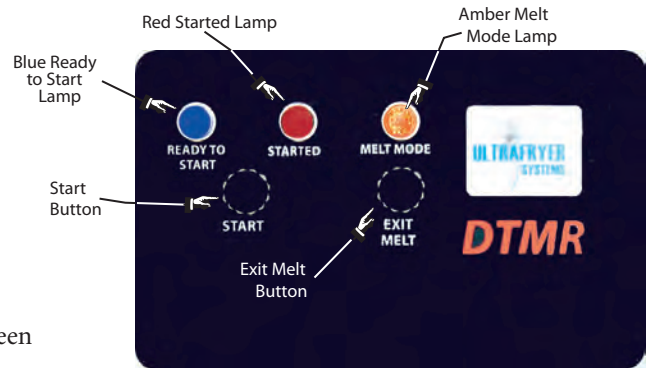

- G. OPTIONAL CONTROLS:** The Model EUHE electric fryer may be equipped with an Ultrastat Model 11, 21, or 25 Cooking Computer as described below:

1. **ULTRASTAT 11 COOKING COMPUTER:** Some Model EUHE electric fryers are equipped with an Ultrastat 11 Cooking Computer which is connected to the fryer's electrical system to serve as its thermostat as well as providing heat control, status information and product cook timer. When the computer is in operation it will DISABLE the fryer if the drain valve is OPENED. Operation of the Ultrastat 11 Cooking Computer is covered in the Ultrastat 11 Ultrafryer Computer Operation Instruction PN 30A053 provided with Fryers equipped with an Ultrastat 11 Cooking Computer.



2. **ULTRASTAT 21 COOKING COMPUTER:** The Ultrastat21 Cooking computer is in compliance with the limits for a class B computing device pursuant to Sub-Part J of Part 15 of the FCC Rules. This cooking computer is capable of cooking up to eight (8) different products; each of which can be programmed to be cooked from one (1) to ten (10) different temperature at different times in a cook cycle. In addition, the operator can program the ULTRASTAT 21 computer to cook products under “FLEX” or “STRAIGHT” timing modes. When programmed for “FLEX” time mode the computer will adjust the actual cook time taking into consideration the temperature variation due to load size, initial product temperature, product moisture content and other factors that affect the cook cycle. Under “STRAIGHT” time mode, the product is cooked at a specified temperature for the length of time programmed without adjusting for these variations. Operation of the ULTRASTAT 21 cooking computer is covered in the ULTRASTAT 21 Gas Fryer Computer Operation Instructions PN 30A009 provided with fryers equipped with this computer.

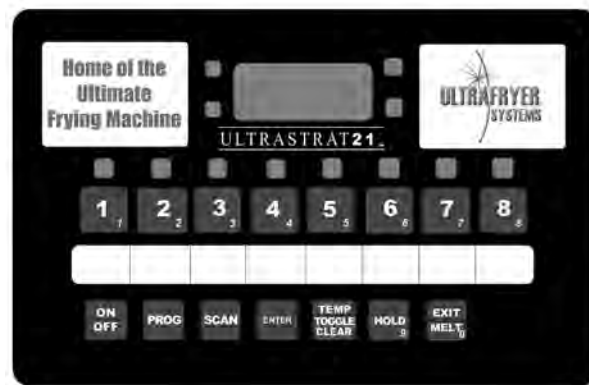

3. **ULTRASTAT 25** : The Ultrastat 25 Cooking Computer is a high performance, micro-processor based electronic controller designed for use in commercial appliance temperature and timing control applications. Utilizing a microcontroller board, membrane switch front panel with a digital LED readout, and display board, the Ultrastat 25 Cooking Computer has been customized for Ultrafryer Systems applications by the addition of up to (10) stage cooking profiles for each of the (8) product keys, exit melt feature, optional temperature setback and filtering prompts, and can be programmed to cook products under “**FLEX**” or “**STRAIGHT**” timing modes. Operation of the Ultrastat 25 Cooking Computer is covered in its Instruction Manual PN 30A051 provided with the Fryers Equipped with this computer.

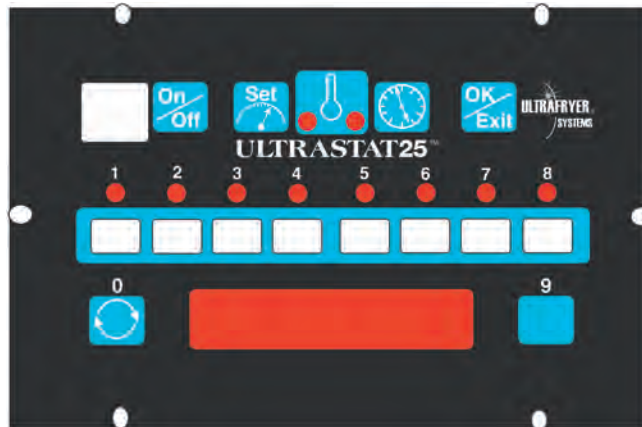

INITIAL START-UP

- A. **START-UP:** The fryers are tested, adjusted and calibrated prior to being shipped: however adjustments may be necessary during installation to meet local conditions, and to correct possible problems caused by rough handling or vibration during shipment. Initial calibration or adjustment is the responsibility of the customer and will not be covered by the Ultrafryer Systems warranty.

NOTE: Calibration and adjustments must be performed by qualified personnel.

- B. **START-UP PROCEDURES:** Perform the following steps, in sequence, to start-up the fryer:

1. Turn the Toggle **SWITCH** to the **OFF** position.
2. Fill the fryer vessel with hot or cold water to the **SHORTENING LEVEL** mark.

CAUTION : IF THE HEAT ELEMENTS ARE OPERATED WITH THE VESSEL EMPTY, THE HEAT WILL CAUSE THE JOINTS OF THE FRYER VESSEL TO BE PLACED UNDER UNDO STRESS AND MAY CAUSE THE VESSEL TO WARP OR BUCKLE, VOIDING THE VAT WARRANTY.

3. Turn the **ON/OFF** switch **ON**; then place the **DTMR** or **ULTRASTAT** Cooking Computer into the **MELT MODE**.
4. The **AMBER** power lamp beside the toggle **ON/OFF** switch will light and the **BLUE READY** to start lamp on the **DTMR** will **LIGHT**

CAUTION: ENSURE THE HEAT ELEMENTS ARE COVERED WITH WATER

5. Depress, then release the momentary **START** button on the **DTMR**. The **RED STARTED** lamp and **AMBER MELT MODE** lamp will **LIGHT**, and the **BLUE READY TO START** lamp on the **DTMR** will turn **OFF**.
6. Turn the fryer toggle **ON/OFF** switch to the **OFF** position, then **CAREFULLY** drain the vat water into a floor drain.

C. SHORTENING INSTALLATION:

1. **LIQUID SHORTENING:** When using liquid shortening fill the fryer with cool shortening 1/2" (13mm) BELOW the "E" in the word LEVEL.. When heated ensure shortening is even with the "E" in the word LEVEL.
2. **SOLID SHORTENING:**
 - a) Cut a block of solid shortening into small pieces.
 - b) Place small pieces of solid shortening **EVENLY** on top of the **HEAT ELEMENTS** or **THOROUGHLY PACK** these pieces of solid shortening between, below and above the **HEAT ELEMENTS**. While packing solid shortening is messy and time consuming, it is the fastest way to melt solid shortening.
 - c) Turn the fryer ON/OFF switch to the **ON** position; then place the **DTMR** or other fryer control in the **MELT MODE**.
 - d) Once the **HEAT ELEMENTS** are completely covered with **LIQUID** shortening and the shortening temperature has been either, heated by a **DTMR** or the applicable computer **MELT LIMIT TEMPERATURE** has been reached, replace the grill in the fryer vat and place the fryer in the **FULL ON** mode.
 - e) Continue adding solid shortening as follows:
 - 1) Place small pieces of solid shortening into a fry basket.
 - 2) **CAREFULLY** lower the basket into the fryer vat.
 - 3) **GENTLY** turn the basket to allow these pieces of solid shortening to float away.
 - 4) Repeat the above steps until liquid shortening is even with the middle line of the "E" in the word **LEVEL** of the shortening level mark on the rear wall of the fryer vat

WARNING!!! TO AVOID INJURY

- I **DO NOT MOVE A FRYER FILLED WITH HOT LIQUID.**
- II **THE FRYER MUST BE RESTRAINED BY USE OF A RESTRAINING DEVICE TO PREVENT TIPPING TO AVOID THE SPLASHING OF HOT LIQUID.**
- III **THE AREA SURROUNDING THE FRYER MUST BE KEPT FREE AND CLEAR OF ALL COMBUSTIBLES.**
- VI **ALWAYS WEAR OIL-PROOF, INSULATED GLOVES WHEN WORKING WITH A FRYER FILLED WITH HOT OIL.**
- V **ALWAYS DRAIN HOT OIL INTO A METAL TUB, POT OR CAN ... HOT OIL CAN MELT PLASTIC BUCKETS OR SHATTER GLASS CONTAINERS.**

D. START-UP AND COOKING

1. **GENERAL :**
 - a. The Default-to-Manual-Restart (DTMR) Control along with an Electronic Thermostat is connected to a fryer's electrical system to control operation of the fryer. The DTMR contains a Default-to-Off circuit that will **DISABLE** the fryer anytime the Drain Valve is **OPEN**, and a Default-to-Melt circuit that will automatically place the fryer in a **SHORTENING MELT MODE** to gradually and safely heat shortening each time the fryer's Toggle Switch is turned **ON**.
 - b. **Electronic Thermostat:** The Electronic Thermostat has a temperature range from 200°F (93°C) to 400°F (204°C) and will accurately maintain a pre-set shortening cook temperature within $\pm 2^\circ$ of the pre-set temperature.



2. START-UP :

- a. TO TEST OPERATE an Ultrafryer electric Fryer equipped with a Default-to-Manual-Restart (DTMR) control:
- 1) Ensure the fryer’s toggle switch is in the OFF position.
 - 2) Fill the fryer vat with shortening to the middle of the “E” in the word LEVEL of the shortening level mark on the rear of the vat.
 - 3) ENSURE the vent hood exhaust fan is ON and operating properly.
 - 4) Perform the following steps, in the order listed:

ITEM	ACTION	DTMR CONDITION
1	ENSURE the drain valve is in the CLOSED position and that shortening is at the proper level; then turn the Toggle switch to the ON position.	A. The AMBER power indicator will LIGHT. B. BLUE READY TO START lamp will LIGHT.
CAUTION: PRIOR TO PROCEEDING TO STEP 2 VISUALLY CHECK THAT THE HEAT MECHANISM IS COVERED WITH AT LEAST 2” (51 mm) OF SHORTENING.		
2	Depress, then release the momentary START button	A. RED STARTED lamp and AMBER MELT MODE lamp will light. B. BLUE READY TO START lamp will turn OFF. C. A TIMER in the Default-To-Melt electrical circuit will begin cycling the fryer heat mechanism ON for four (4) seconds and OFF for 36 seconds to safely heat the water.
CAUTION: PRIOR TO PROCEEDING TO STEP 3, VISUALLY CHECK THAT THE SHORTENING COMPLETELY COVERS THE HEAT MECHANISM.		
3	When the shortening is heated depress, then release the momentary EXIT MELT button.	A. AMBER MELT MODE lamp will turn OFF and the RED STARTED lamp will remain lit. B. The TIMER in the Default-To-Melt circuit will switch to the FULL ON position, allowing the Electronic Thermostat to heat water to its pre-set temperature.
4	When the fryer’s RED heat indicator lamp turns OFF, indicating the pre-set temperature has been reached, turn the toggle switch to the OFF position.	
<p>Steps 1, 2 and 3 will have to be repeated each time any of the following occurs:</p> <p>DRAIN VALVE IS OPENED.</p> <p>TOGGLE ON/OFF SWITCH IS TURNED OFF TO FILTER SHORTENING.</p> <p>TOGGLE ON/OFF SWITCH IS TURNED OFF AT CLOSING.</p>		

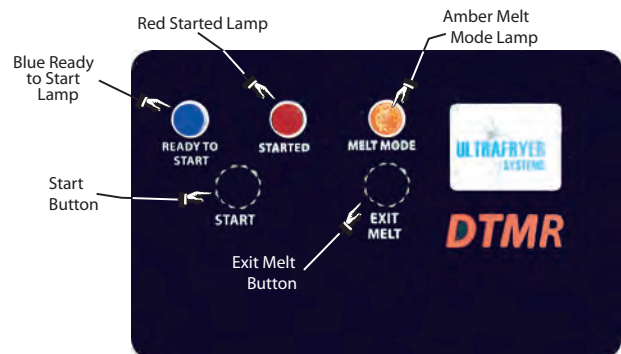
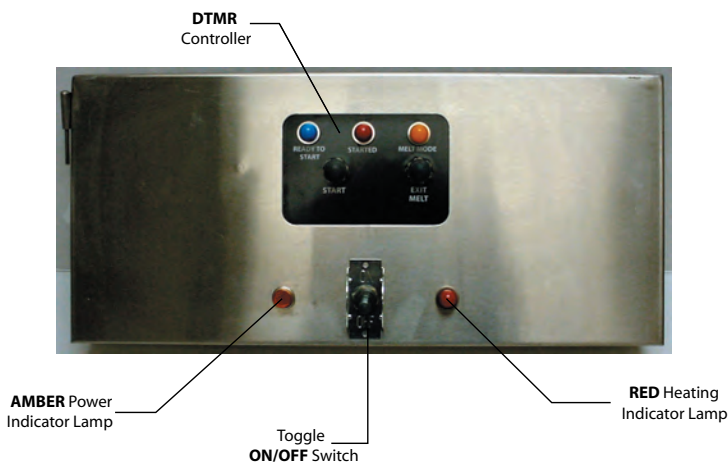

- c. **TO TEST OPERATE** a Ultrafryer electric Fryer equipped with an Ultrastat 11 Cooking Computer, use the procedures contained in the “Ultrastat 11 Ultrafryer Computer Operation Instructions”, PN 30A053, provided with the fryer.
- d. **TO TEST OPERATE** a Ultrafryer electric Fryer equipped with an Ultrastat 21 Cooking Computer, use the procedures contained in the “Ultrastat 21 Ultrafryer Computer Operation Instructions”, PN 30A009, provided with the fryer.
- e. **TO TEST OPERATE** a Ultrafryer electric Fryer equipped with an Ultrastat 25 Cooking Computer, use the procedures contained in the “Ultrastat 25 Ultrafryer Computer Operation Instructions”, PN 30A051, provided with the fryer.

- f. **COOKING:** Most products should be cooked with a shortening temperature about 350°F (177°C); however, each product should be cooked at the **LOWEST** temperature that produces a high quality product while obtaining maximum usage of the shortening.

DO USE A HIGH QUALITY SHORTENING TO ACHIEVE A CONSISTENT QUALITY PRODUCT AND LONG TERM SAVINGS.

DO NOT SALT PRODUCTS OVER THE FRYER AS SALT QUICKLY DETERIORATES THE SHORTENING AND FLAVORS OTHER PRODUCTS COOKED IN THE SAME SHORTENING.

DO FILTER SHORTENING AFTER THE LUNCH AND DINNER RUSH AND MORE OFTEN IN A HIGH SALE VOLUME STORE; AND BOIL-OUT THE FRYER EVERY 7 DAYS.

OPERATING INSTRUCTIONS: This fryer is equipped with a shortening filter system which is to be operated and cleaned according to the operating section of this manual beginning on page 24.

A. GENERAL:

1. **SHORTENING:** Use a high quality shortening to achieve a consistent quality product as well as a long term savings.
2. **SHORTENING TEMPERATURE:** Most products should be cooked with a shortening temperature about 350°F (177°C); however, each product should be cooked at the **LOWEST** temperature that produces a high quality product while obtaining maximum usage of the shortening.
3. **SALTING:** Products should not be salted over the fryer vessel as salt quickly deteriorates the shortening and flavors other products cooked in the same shortening.
4. **POWER FAILURES:** This fryer cannot be operated during power failures. **DO NOT** attempt to bypass safety controls and manually operate the fryer.
5. **PUMP MOTOR:** The filter pump motor is protected by a motor thermal overload switch.

CAUTION: ENSURE THE WASH DOWN HOSE IS NOT CONNECTED TO A FRYER PRIOR TO RESETTING A THERMAL OVERLOAD SWITCH.

- B. FILTERING SHORTENING:** The fryer must be filtered at least twice a day (once after the lunch rush and again after the dinner rush). Place the recommended amount of filter agent in the shortening as prescribed by the chemical supplier and follow instructions for filtering shortening provided in the operating section of this manual beginning on page 24.
- C. LEVELING SHORTENING:** After filtering, the shortening level must be checked and fresh shortening added when necessary.
1. The shortening in the vat should reach to the middle line of the “E” in the word **LEVEL** of the shortening level mark on the rear wall of the fryer.
 2. If shortening is needed, use the filter scraper to cut off a small block of solid shortening.
 3. Place the small block of shortening into a fry basket, lower the basket into the shortening; then turn the basket to allow the block to float freely.
 4. Repeat the above steps until the shortening in the vat is at the proper level.
- D. BOILING OUT FRYER:** The fryer should be **BOILED OUT** every **7 DAYS** to remove carbon buildup and other encrusted materials. Add the amount of boil out compound to the fryer as prescribed in the cleaning manual provided by the chemical supplier and follow instructions for boiling out a fryer in the operating section of this manual beginning on page 24.
- E. CLOSING/SHUTDOWN INSTRUCTIONS:**
1. **CLOSING:** When closing at night; filter the shortening in the fryer, **THOROUGHLY** clean the filter tub, drain all filter lines and cover the fryer vessel. Turn the **TOGGLE** switch on the fryer **OFF**.
 2. **SHUTDOWN OR PROLONGED POWER FAILURE:**
 - a. Shutdown: Perform the following whenever a fryer is being shutdown for an extended period of time:
 - 1) Drain and discard the shortening.
 - 2) **THOROUGHLY** clean the fryer vat and filter tub.
 - 3) Turn the ON/OFF switch to the **OFF** position, disconnect the 120-volt power cord and turn applicable Circuit Breakers **OFF**.
 - b. Prolonged power failure: This fryer cannot be operated during power failures. **DO NOT** attempt to bypass safety controls and manually start the fryer.

CLEANING AND MAINTENANCE

A CLEANING: Any item of equipment operates better and lasts longer when it is kept clean and properly maintained, and this fryer is no exception. In order for the fryer to provide years of trouble-free service, it must be **CLEANED** and **MAINTAINED** according to instructions and at the intervals listed below:

1. DAILY

- a. **FILTER** shortening in each fryer vat after the **LUNCH** and **DINNER** rush and more often in high volume sale stores.

CAUTION: PRIOR TO CLEANING THE FRYER VAT, ENSURE THE TOGGLE ON/OFF SWITCH ON THE FRYER IS OFF.

- b. **CLEAN** the fryer surface with a solution of hot water and detergent periodically during operating hours and with stainless steel cleaner at closing. If necessary, use a dampened 3M type **7447 RED** or 3M type **7440 heavy duty BROWN** Scotchbrite pad to remove encrusted material. **DO NOT** use steel wool, abrasive cloths, cleaners, powders, metal knife, spatula or any other metal object to scrape stainless steel! Scratches on stainless steel are almost impossible to remove!

CAUTION: DO NOT ALLOW ANY CLEANING SOLUTION/WATER TO SPLASH INTO A VESSEL OF HOT COOKING OIL AS IT WILL CONTAMINATE THE OIL AND MAY CAUSE THE OIL TO SPLATTER CAUSING SEVERE BURNS.

- c. **THOROUGHLY** clean the filter tub according to instructions provided on page 22 and 23 in this manual.

2. WEEKLY

- a) **BOIL OUT** the fryer vat using Boil Out Compound according to procedures in the cleaning manual provided by the chemical supplier
- b) Perform steps b) and c) listed above under Daily Cleaning routines.

B MAINTENANCE - If the fryer is equipped with an Ultrastat 11, 21, or 25 Cooking Computer, **NO** maintenance is required on the Temperature Sensing Probe. However, if the fryer is equipped with a Default-to-Manual-Restart (DTMR) Control, the Electronic Thermostat may need to be adjusted or calibrated according to the following procedure:

C. ELECTRONIC THERMOSTAT CALIBRATION - The Electronic Thermostat in all fryer configurations are equipped with a Dial and Knob and should be checked and calibrated when necessary as follows:

1. **ENSURE** electrical power to the fryer has been turned **OFF**.
2. **CAREFULLY** drain sufficient shortening from the fryer to **LOWER** the shortening about 4" (102 mm) beneath the Electronic Thermostat sensing probe.
3. After the sensing probe has **COOLED**, loop the sensor of an **ACCURATE** digital test thermometer temperature probe around the sensing element; then connect the probe to the thermometer.
4. Replace shortening drained in step 2 and **ENSURE** it is level with the shortening level mark on the rear of the vat; then turn the power to the fryer **ON**.
5. Set the **KNOB** of the Electronic Thermostat to the **CENTER** (300) of the dial and periodically **STIR** the shortening in a **COUNTER-CLOCKWISE (CCW)** direction with a long handle skimmer to pull congealed shortening **UPWARD** from the Cold Zone area.
6. When shortening has reached the set point temperature and the **RED** indicator lamp on the fryer has turned **OFF**, allow the Electronic Thermostat to cycle **ON** and **OFF** about five (5) times to stabilize the system.

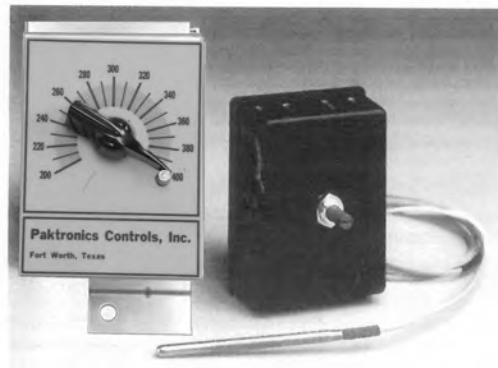

7. After the shortening temperature has stabilized, record the temperature reading of the **TEST THERMOMETER** immediately after the **RED** indicator lamp and the fryer turns **OFF**.
8. **CAREFULLY** loosen the set screw on the Electronic Thermostat **KNOB** without turning the thermostat potentiometer, set the thermostat knob pointer to the temperature recorded by the test thermometer; then tighten the set screw on the thermostat knob taking care not to turn the thermostat's potentiometer.
9. Repeat steps 1 and 2 above, remove the test thermometer temperature probe from the Electronic Thermostat sensing element; then repeat step 4 to return the fryer to normal operation.

PREVENTIVE MAINTENANCE AND TROUBLE SHOOTING

A. PREVENTIVE MAINTENANCE

Minimal maintenance is required on the fryer because of its design and the materials used in the manufacturing process. However, some preventive maintenance and inspection must be performed periodically to prevent break downs which could curtail food sales. Any preventive maintenance or inspection should be accomplished with **CAUTION** while the fryer is in operation since **HOT** liquid shortening could cause severe burns. If service or repair is required, all electrical power **MUST BE TURNED OFF PRIOR TO** performing that service or repair.

PREVENTIVE MAINTENANCE SCHEDULE		
<u>INSPECTION ITEM</u>	<u>INSPECTION PRIORITY</u>	<u>INSPECTION DESCRIPTION</u>
Grease Filters	DAILY	Clean grease filters in the exhaust hood each evening and allow them to dry overnight.
Filter Tub	DAILY	Thoroughly clean the filter tub assembly prior to leaving the store at closing
Drain Valve & Shortening Return Levers	WEEKLY	Determine that all levers are securely attached and that they can be easily opened and closed.
Temperature Sensing Probes	WEEKLY	During Boil-Out of the fryer, inspect the temperature and high limit sensing probes for any visual damage.

B. TROUBLESHOOTING

I. GENERAL: The problems and possible solutions listed in the troubleshooting chart below are typical problems that are frequently encountered. **ONLY** qualified repairmen are to use the troubleshooting chart to repair this fryer. In the event a heat element malfunction occurs, perform the following checks **PRIOR** to contacting a repairman:

- a. Check that the fryer electrical plug is connected to an electrical receptacle.
- b. Ensure the applicable Circuit Breaker is in the **ON** position and that the fryer ON/OFF switch is in the **ON** position.
- c. Ensure the applicable fryer control has been placed in the **FULL ON** mode.

C. TROUBLESHOOTING CHART: Should a problem occur that cannot be corrected after performing the above **CHECKS**, contact an authorized repairman and/or Ultrafryer Systems Customer Service 1-800-525-8130 and provide the information acquired while performing these checks.

CAUTION: ENSURE REPAIRMEN ARE ADVISED THAT FRYER RESTRAINTS MUST BE DISCONNECTED/CONNECTED. IF A FRYER IS TO BE MOVED DURING MAINTENANCE OR REPAIR, AND THAT ELECTRICAL POWER MUST BE TURNED OFF PRIOR TO PERFORMING ANY MAINTENANCE OR REPAIR.

TROUBLESHOOTING CHART		
ITEM	PROBLEMS	POSSIBLE SOLUTIONS
1	The filter pump motor fails to operate when the Vat Shortening Return / Topside Shortening Return Lever is placed in the OPEN position.	A. Insure the filter pump micro-switch is good, then check the manual reset button on the filter pump motor. B. If the filter pump motor fails to operate after the reset button has been depressed, repair or replace the motor.
2	Decreased shortening flow rate while filtering.	A. Check for excessive sediment on the filter screen, standpipe suction fitting or in filter tub.
3	Pump/Motor operates but does not pump shortening.	A. Check for congealed shortening in the shortening system. B. Check for loose Standpipe / Suction Line Coupler connection.
4	Pump / Motor hums but will not pump shortening	A. Check for congealed shortening in the pump or in shortening plumbing.
5	Excessive smoke from shortening	1. Check the computer program to ensure the Pre-set cook temperature is correct. 2. Shortening breakdown has occurred. Replace the shortening.
6	Process Contactor chatters	1. Check and/or tighten the contactor coil connections. 2. Defective contactor. Replace the contactor.
7	Excessive time is required to raise the shortening to cooking temperature. Temperature recovery is slow.	1. Check that 3 Phase 208/240 voltage is supplied to heat element. 2. Defective heat element (SEE NOTE)
8	Decreased shortening flow rate while filtering	1 Check for excessive sediment on the filter screen, standpipe suction fitting or in the filter tub.

NOTE: The most effective means to determine if a Heat Element is operational is to measure the Current Draw of an Element with an Amp Probe. The Current drawn by a good Heat Element should be close to the values shown below:

INPUT ELECTRICAL SERVICE

CURRENT TO ONE HEATING ELEMENT

208 VOLTS
240 VOLTS

27.8 AMPERES
24.0 AMPERES

RECOMMENDED SPARE PARTS: To minimize downtime on the Model EUHE electric fryer upon failure of a component part, at least one (1) of the following items should be kept as a spare part in the local area:

18" MODEL EUHE ELECTRIC FRYER RECOMMENDED SPARE PARTS LISTING	
<u>Description</u>	<u>PN</u>
208/240 Volt 3 Phase 60 Ampere Mercury Contactor	18231
Type K 120 to 24 Volt 100 KVA square D step down Transformer	18A010
208 Volt 3 Phase 10 KW Heat Element OR 240 Volt 3 Phase 10 KW Heat Element	18A012 18A015
NOTE: ORDER A HEAT ELEMENT TEFLON WASHER PN 18174 WHEN ORDERING A REPLACEMENT HEAT ELEMENT	
SPDT Toggle ON/OFF Switch	18A287
High Limit Switch Pre-Set to trip at 450°F (232°C) NOTE: Order a compression fitting PN 24247 when ordering this item.	19A145
Class RK5 35 Ampere 250 Volt Time Delay Fuse	23A043
1/2" (13MM) Apollo Pump Control Valve	24036

CLEANING - Any item of equipment operates better and lasts longer when it is kept clean and properly maintained. The Model EUHE electric Fryer is no exception. In order for this fryer to provide years of trouble-free service, it must be **CLEANED** and **MAINTAINED** according to instructions herein and at the intervals listed below:

**WARNING!!! TO ASSURE PRODUCING A QUALITY PRODUCT WHILE PROLONGING THE LIFE
EXPECTANCY OF THE FRYER, ENSURE FILTERING, BOIL-OUT AND CLEANING
INSTRUCTIONS ARE STRICTLY ADHERED TO.**

A. DAILY

1. Clean the fryer surface periodically during operating hours with a solution of sanitizer and hot water, and at closing with stainless steel cleaner. If necessary, use a dampened **3M** type **7447 RED** or **7440 BROWN** (heavy duty) Scotchbrite pad to remove encrusted material. **DO NOT** use steel wool, abrasive cloths, cleaners, powders or metal devices to scrape stainless steel! Scratches on stainless steel are almost impossible to remove!

CAUTION: DO NOT ALLOW ANY CLEANING SOLUTION OR WATER TO SPLASH INTO A VESSEL OF HOT COOKING OIL, AS IT WILL CONTAMINATE THE OIL AND MAY CAUSE THE OIL TO SPLATTER CAUSING SEVERE BURNS.

2. The Filter Tub Assembly and Filter Screen should be cleaned **EACH DAY** after **FILTERING** and **AT CLOSING** and **THOROUGHLY** cleaned once each week. To remove the Filter Tub Assembly from the fryer:
 - a) **OPEN** the Fryer's Temperature Control Access Door,
 - b) **DEPRESS** the **DOCKING RELEASE HANDLE**, shown on page 34.
 - c) **PULL** the Filter Tub Assembly from the fryer.
 - d) Disassemble the Filter Tub Assembly in the following sequence:
 - 1). filter tub cover
 - 2) crumb catcher screen
 - 3) filter screen standpipe/docking assembly; then separate the standpipe/docking assembly from the filter screen
 - e) Clean the Filter Tub and Filter Screen as follows:

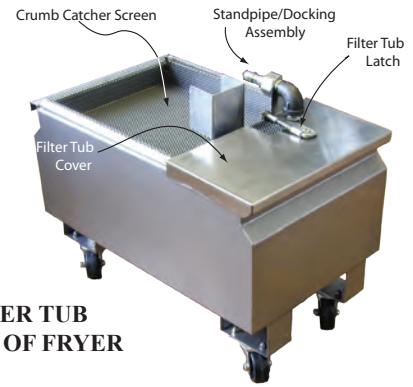

**FILTER TUB
OUT OF FRYER**

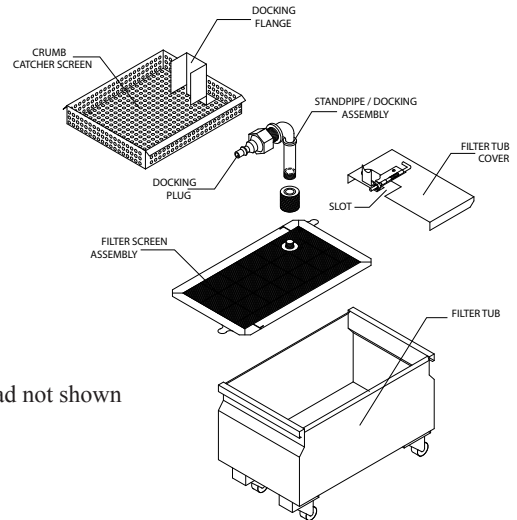
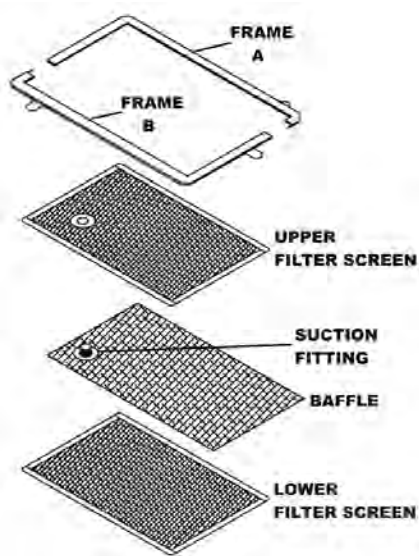

NOTE: Magnepad Filter Pad not shown

3. CLEANING THE FILTER TUB AFTER FILTERING SHORTENING

- a. Disassemble the Filter Machine by removing the following items in the order listed; 1) **FILTER TUB COVER**, 2) **CRUMB CATCHER SCREEN**, 3) **FILTER SCREEN W/STANDPIPE/DOCKING** attached; then 4) separate the **STANDPIPE** and **DOCKING ASSEMBLY** from the Filter Screen.
- b. Clean the Wash Down Hose with sanitizer solution; then hang the Wash Down Hose in an upright position so shortening can drain into a container.
- c. Discard crumb fragments in the Crumb Catcher Pan and **THOROUGHLY** clean the pan with **HOT** water and let it air dry.
- d. Raise the Filter Assembly with Standpipe and Docking Assembly attached, above the Filter Tub and let any sediment or shortening drain into the tub; then separate the standpipe/docking assembly from the Filter Screen and clean the assembly with sanitizer solution and wipe it dry with a lint free cloth. **THOROUGHLY** clean the filter assembly as follows:
 - 1) "Micro-Mesh" Stainless Steel Filter Screen
 - a) **CAREFULLY** remove any debris from the screen using a scraper.
 - b) Grasp the **FINGER LOOP** on **FRAME A** and adjacent **FINGER LOOP** on **FRAME B**, **EVENLY** pull the frames apart; then **HINGE** FRAME A to remove it from the **FILTER SCREENS FIRST**.
 - c) Grasp the **FINGER LOOP** on the straight side of **FRAME B**; then **HINGE** it to remove FRAME B from the **FILTER SCREENS**.
 - d) Separate the **UPPER FILTER SCREEN** and **BAFFLE** from the **LOWER FILTER SCREEN**.
 - e) **CAREFULLY** clean the two frames, screens and baffle in the 3 compartment sink with hot water and allow these items to air dry. **DO NOT USE SOAP**. If necessary the channels in each frame can be cleaned with the edge of a scotchbrite pad.
 - f) Insert the **SUCTION FITTING** on the **BAFFLE** in the hole of the **UPPER FILTER SCREEN**; then place these items on top of the **LOWER FILTER SCREEN**.
 - g) **ENSURE** all sides of the **FILTER SCREEN** assembly are aligned, place the **PIN** end of **FRAME A** on the **FILTER SCREENS**, place the **CHANNEL** on the frame adjacent to the **PIN** end over the **FILTER SCREENS**;

then **HINGE** the frame so the edge of the **FILTER SCREENS** are inserted in the other **CHANNEL** of **FRAME A**.

- h) Place the **PIN** end of **FRAME B** on the **FILTER SCREENS** so the **PIN** is seated in the **CHANNEL** of **FRAME A** near the **FINGER LOOP**, place the **CHANNEL** on the frame adjacent to the **PIN** end over the edge of the **FILTER SCREENS**; then **HINGE** the frame so the edge of the **FILTER SCREENS** are inserted in the other **CHANNEL** of **FRAME B** and the **PIN** of **FRAME A** is seated in the **CHANNEL** of **FRAME B**.
 - i) Adjust **FRAME A** and **B** so both **PINS** are properly seated in the **CHANNEL** of the opposite frame; then **CAREFULLY** connect the **KNURL KNOB** on the **STANDPIPE/DOCKING ASSEMBLY** to the **SUCTION FITTING** on the **FILTER SCREEN** assembly. **DO NOT OVERTIGHTEN!!!**
- 2) Magnepad Envelope Filter: Magnepad Filter Assemblies **DO NOT** have to be **SCRAPED** after filtering shortening.
- e. Remove any sediment and shortening in the Filter Tub using a scraper; then wipe the tub dry with paper towels.
 - f. **CAREFULLY** insert the assembled Filter Screen in the bottom of the Filter Tub; then **CAREFULLY** insert the Crumb
 - g. **CAREFULLY** position the **FILTER TUB COVER** on the **OPEN** end of the Filter Tub with the **SLOT** on the cover seated around the Standpipe/Docking Assembly. Then, **SECURE** the cover to the standpipe assembly by locking the latch on the cover.
 - h. Position the **ASSEMBLED** Filter Tub in front of the **FILTER TUB GUIDES** beneath the fryer; then **CAREFULLY** and **SLOWLY** insert the Filter Tub into the fryer until the **MALE** In Line Plug on the Docking Assembly seats in the **FEMALE** Bulkhead Coupling adjacent to the Drain Valve Assembly.

4. **CLEANING THE FILTER TUB AFTER CLOSING**

a. "Micro Mesh" Stainless Steel Filter Screen:

Repeat **DAILY** steps A 1 page 21; then, **THOROUGHLY** clean the Filter Assembly as follows:

- 1) **THOROUGHLY** flush any remaining sediment from both sides of the filter screen with **HOT WATER**.
- 2) Grasp the **FINGER LOOP** on **FRAME A** and adjacent **FINGER LOOP** on **FRAME B**, **EVENLY** pull the frames apart; then **HINGE FRAME A** to remove it from the **FILTER SCREENS FIRST**.
- 3) Grasp the **FINGER LOOP** on the straight side of **FRAME B**; then **HINGE** it to remove **FRAME B** from the **FILTER SCREENS**.
- 4) Separate the **UPPER FILTER SCREEN** and **BAFFLE** from the **LOWER FILTER SCREEN**. **CAREFULLY** clean the two frames, screens and baffle in the 3 compartment sink with hot water and allow these items to air dry. **DO NOT USE SOAP**. If necessary the channels in each frame can be cleaned with the edge of a scotchbrite pad.
- 5) Insert the **SUCTION FITTING** on the **BAFFLE** in the hole of the **UPPER FILTER SCREEN**; then place these items on top of the **LOWER FILTER SCREEN**.
- 6) **ENSURE** all sides of the **FILTER SCREEN** assembly are aligned, place the **PIN** end of **FRAME A** on the **FILTER SCREENS**, place the **CHANNEL** on the frame adjacent to the **PIN** end over the **FILTER SCREENS**; then **HINGE** the frame so the edge of the **FILTER SCREENS** are inserted in the other **CHANNEL** of **FRAME A**.
- 7) Place the **PIN** end of **FRAME B** on the **FILTER SCREENS** so the **PIN** is seated in the **CHANNEL** of **FRAME A** near the **FINGER LOOP**, place the **CHANNEL** on the frame adjacent to the **PIN** end over the edge of the **FILTER SCREENS**; then **HINGE** the frame so the edge of the **FILTER SCREENS** are inserted in the other **CHANNEL** of **FRAME B** and the **PIN** on **FRAME B** is seated in the **CHANNEL** of **FRAME A**.
- 8) Adjust **FRAME A** and **B** so other **PINS** are properly seated in the **CHANNEL** of the opposite frame; then **CAREFULLY** connect the **KNURL KNOB** and **STANDPIPE/DOCKING ASSEMBLY** to the **SUCTION FITTING** on the **FILTER SCREEN** assembly. **DO NOT OVERTIGHTEN!!!**

b. "Magnepad" Envelope Filter:

Remove and discard the **USED** Filter Pad Envelope. **CAREFULLY** clean the Baffle Assembly and Clip/Stand-pipe assembly in the 3 compartment sink with **HOT** water and allow these items to air dry. **DO NOT USE SOAP!!**

Reassemble the Magnepad Envelope Filter using a **NEW** Magnesol Impregnated Filter Pad Envelope as follows:

- 1) Insert the **BAFFLE** into the **FILTER PAD ENVELOPE**, when properly inserted the **SUCTION FITTING** will protrude through the hole in the pad.
- 2) Fold the **FLAP** over (in the direction of the hole) securing the Baffle inside the **FILTER PAD ENVELOPE**.
- 3) **CAREFULLY** align the **CLIP & STANDPIPE ASSEMBLY** so that the clip can secure the **FLAP** and the envelope and the **STANDPIPE** will align over the **SUCTION FITTING** protruding through the envelope.
- 4) Tighten the knurled **NUT** on the **STANDPIPE** to the **SUCTION FITTING** protruding through the envelope.
- 5) Repeat **DAILY** steps A 1 through A 4 pages 21,22 and above.

B. WEEKLY

1. Perform daily cleaning steps A1 through A3 on page 21 and 22.
2. Clean the Filter Assembly as follows:
 - a) “Micro-Mesh” stainless steel filter screen:
 - 1) Disassemble the filter accordingly to DAILY steps A 3 d and clean the two (2) frames as described in step A 3 d 1 e) page 21.
 - 2) Place the upper and lower FILTER SCREENS in the fryer with BOIL-OUT SOLUTION for cleaning. DO NOT PLACE THE BAFFLE OR STANDPIPE IN THIS SOLUTION!!! BOIL-OUT the fryer vat according to instructions contained in the cleaning manual provided by your chemical supplier.
 - 3) After the filter screens have been cleaned in the Boil-Out Solution, ENSURE they are THOROUGHLY sprayed with a solution of 1 PART vinegar to 25 PARTS of water to NEUTRALIZE the boil-out solution, then allow the screens to air dry. NOTE: any residue of boil-out solution on the filter screens could cause the rapid break-down of the shortening.
 - 4) Reassemble the “Micro-Mesh stainless steel filter according to DAILY steps A4a page 23.
 - b) “Magnepad” Envelope Filter – Disassemble, clean, and re-assemble the “Magnepad” Filter Assembly according to DAILY cleaning steps A4e page 23.
3. Place the CRUMB CATCHER PAN and SLUDGE CATCHER SCREEN in the fryer with the Boil-Out Solution for cleaning, and after they are cleaned, ENSURE they are sprayed with a solution of vinegar/water as described in WEEKLY step B 2 a) 3) above.
4. THOROUGHLY clean the Filter Tub, Cover and Sludge Catcher Pan with HOT SANITIZER SOLUTION and allow them to air dry.
5. Re-assemble the Filter Tub according to DAILY steps A 3 f through A 3 h page 22 and 23.

WARNING: WHEN ASSEMBLED, ENSURE THERE ARE NO FINGER LOOPS ON THE STANDPIPE SIDE OF THE MICRO_MESH FILTER.

OPERATION

A. GENERAL - The “basic” Model EUHE electric Fryer is equipped with a Default-to-Manual-Restart (DTMR) Control, which uses an Electronic Thermostat. Some fryers are equipped with an Ultrastat 11,21 or 25 Cooking Computer that use the same Temperature Sensing Probe. In this section, the operation of the EUHE electric Fryer will cover the Default-to-Manual-Restart (DTMR) Control and the Ultrastat 11 Cooking Control.

NOTE: Refer to Manual PN 30A009, ULTRASTAT 21 Cooking Computer Operation Instruction; or Manual PN 30A051, ULTRASTAT 25 Cooking Computer Operation Instructions for operation of a fryer with one of these controls.

B. DEFAULT-TO-MANUAL-RESTART (DTMR) CONTROL

1. **BLUE READY TO START LAMP** - When lit indicates the fryer’s Toggle ON/OFF switch is in the **ON** position, the Drain Valve is **CLOSED** and the fryer is ready to be placed in operation.
2. **START BUTTON** - When the button is momentarily depressed, it places the fryer in operation.
3. **RED STARTED LAMP** - When lit indicates the **START BUTTON** has been depressed, placing the fryer in operation.
4. **AMBER MELT MODE LAMP** - When lit indicates the fryer is in the **MELT MODE** and that the melt cycle timing module in the DTMR Default-to-Melt circuit is turning the fryer’s heat mechanism **ON** and **OFF**, to gradually and safely heat the shortening.
5. **EXIT MELT BUTTON** - When this button is momentarily depressed, the melt cycle timing module in the DTMR’s Default-to-Melt circuit will switch to the **FULL-ON** position allowing the Electronic Thermostat to heat shortening to its **PRE-SET** temperature.

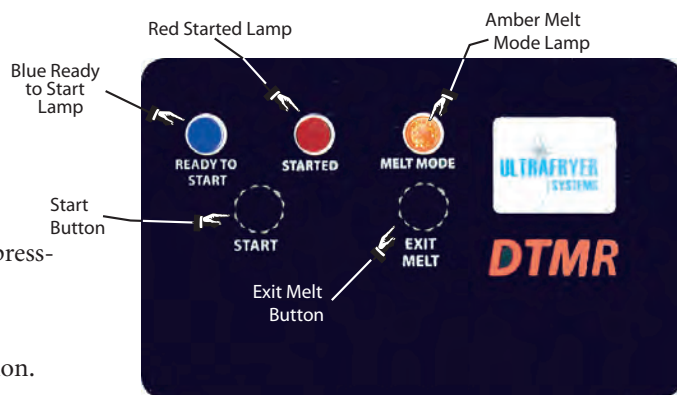

C. **DTMR OPERATION** - Prior to operating the Model EUHE electric Fryer, **ENSURE** the Filter Tub Assembly is properly installed and **DOCKED** to the fryer's Bulkhead socket and the Temperature Control Access Door is closed, the fryer vat is filled with shortening to the middle of the "E" in the word **LEVEL** of the shortening level mark on the rear wall of the vat; then:

1. Turn the Toggle Power Switch to the **OFF** Position.
2. **ENSURE** the vent hood **EXHAUST FAN** is **ON** and operating properly.
3. Perform the following steps, in the order listed:



ITEM	ACTION	DTMR CONDITION
1	ENSURE the drain valve is in the CLOSED position and that shortening is at the proper level; then turn the Toggle switch to the ON position.	A. AMBER power lamp will LIGHT. B. BLUE READY TO START lamp will LIGHT.
CAUTION: PRIOR TO PROCEEDING TO STEP 2 VISUALLY CHECK THAT THE HEAT ELEMENTS ARE COVERED WITH AT LEAST 2" (51 mm) OF SHORTENING.		
2	When the shortening is heated, depress then release the momentary START button.	A. RED STARTED lamp and AMBER MELT MODE lamp will light. B. BLUE READY TO START lamp will turn OFF. C. The MELT CYCLE TIMING MODULE in the Default-To-Melt electrical circuit will begin cycling the fryer heat elements ON for four (4) seconds and OFF for 36 seconds to safely heat the shortening.
CAUTION: PRIOR TO PROCEEDING TO STEP 3, VISUALLY CHECK THAT THE SHORTENING COMPLETELY COVERS THE HEAT ELEMENTS.		
3	When the shortening is heated, depress then release the momentary EXIT MELT button.	A. AMBER MELT MODE lamp will turn OFF, RED STARTED lamp will remain lit. B. The Melt Cycle Timing Module in the Default-To-Melt circuit will switch to the FULL ON position allowing the Electronic Thermostat to heat shortening to its pre-set temperature.
4	When the fryer's pre-set temperature has been reached, initiate a cook cycle.	

NOTE: For more detailed information on the Ultrastat 11 Cooking Computer including how to program the computer refer to the Ultrastat 11 Cooking Computer Operating Instructions PN 30A053 provided with the fryer.

FILTER TUB ASSEMBLY AND INSTALLATION

A. FILTER TUB ASSEMBLY - ENSURE all components of the filter tub have been thoroughly cleaned and that the Filter Screen has been assembled according to the Cleaning Section, page 22 paragraph A3 of this manual then assemble the filter tub as follows:

1. Connect the **KNURLED KNOB** to the **STANDPIPE/DOCKING ASSEMBLY**; then attach this assembly to the **SUCTION FITTING** on the Filter Screen.

DO NOT OVERTIGHTEN THIS CONNECTION!!!

2. **CAREFULLY** place the Filter Screen in the bottom of the Filter Tub with the screen butted against the rear wall of the tub.
3. **CAREFULLY** insert the Crumb Catcher Screen in the Filter Tub with the Drain Valve **DOCKING FLANGE** and **MALE DOCKING PLUG** over the leading edge of the pan.
4. **CAREFULLY** position the **FILTER TUB COVER** on the open end of the Filter Tub with the **SLOT** on the cover seated around the Standpipe/ Docking Assembly. Then, **SECURE** the cover to the standpipe assembly by locking the latch on the cover. (See photo on next page.)

B. FILTER TUB INSTALLATION - Position the **ASSEMBLED** Filter Tub in front of the **FILTER TUB GUIDES** beneath the fryer; then **CAREFULLY** and **SLOWLY** insert the Filter Tub into the fryer until the **MALE In-Line Plug** on the Docking Assembly seats in the **FEMALE** Bulkhead Socket adjacent to the Drain Valve Assembly as shown on the next page.

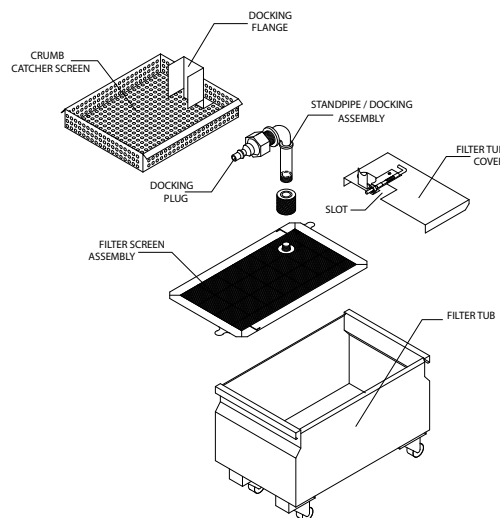

FILTERING AND POLISHING SHORTENING

A. FILTERING SHORTENING

1. Turn the **TOGGLE SWITCH** to the fryer **OFF**, and ensure the filter tub is properly docked beneath the drain valve.

NOTE: Pull on the filter tub to **ASSURE** the male docking plug is **SEATED** in the female bulkhead socket.

2. Place the amount of **FILTER AGENT** into the fryer vat as prescribed in the cleaning manual provided by your chemical supplier; thoroughly stir the filter agent into the shortening using a skimmer; then skim the shortening to remove any floating crumbs.

CAUTION: **PRIOR TO PROCEEDING TO THE NEXT STEP, PUT ON SAFETY GOGGLES, NEOPRENE INSULATED GLOVES AND AN APRON.**

3. Carefully attach the drain valve handle to the drain valve; then open the drain valve by turning the **DRAIN VALVE HANDLE** slightly downward. When the bottom of the filter tub is covered with about two (2) inches of shortening, completely **OPEN** the drain valve, and while shortening is draining, scrape all sides of the vat to remove encrusted material using the scraper.
4. When all shortening has drained into the filter tub, use the **DRAIN ROD** to stand the wire rack on one side of the vat.
5. Use the drain rod to pull the sediment on the bottom of the vat towards the valve opening, then use the rod to push sediment through the valve opening.

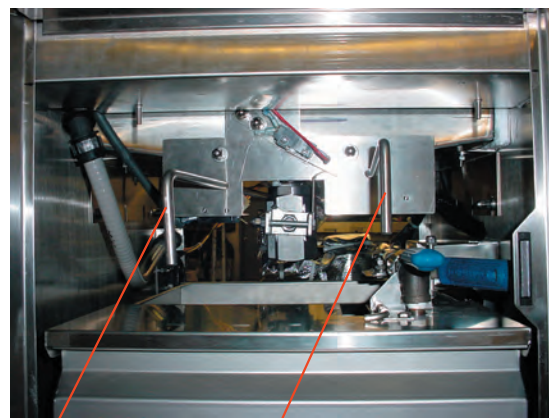

Vat Shortening
Return Lever
(Shown In Closed Position)

Topside Shortening
Return Lever
(Shown In Closed Position)

CAUTION: **DO NOT ACTIVATE (TURN) THE VAT SHORTENING RETURN LEVER AND TOPSIDE SHORTENING LEVER AT THE SAME TIME! TO DO SO WILL REDUCE SHORTENING FLOW.**

6. If there is **NO** sediment or debris visible on the heat elements or bottom of the vat, **CLOSE** the drain valve; then turn the **LEFT HAND** Vat Shortening Return Lever $\frac{1}{4}$ **turn counter clockwise** to automatically return shortening in the filter tub through the **SWEEP NOZZLE** in the bottom of the vat. When all shortening has been returned to the vat, turn the **LEFT HAND** Vat Shortening Return Lever $\frac{1}{4}$ **turn clockwise** to stop the flow of shortening; then proceed to paragraph B page 30.
7. If there is considerable sediment and debris on the bottom of the vat, **FLUSH** this sediment from the vat using the Wash Down Hose or **OPTIONAL** Automatic Vat Cleaner (AVC) also referred to as **SPRAY BLASTER**, as described below.
 - a. Fryer **WITHOUT** an Automatic Vat Cleaner (AVC) <Spray Blaster>
 - 1) Leave the drain valve in the **OPEN** position, **CAREFULLY** connect the Wash Down Hose **Male In-Line Plug** to the **TOPSIDE FEMALE SOCKET**; then place the Wash Down Hose nozzle into the vat and hold it firmly against an inner wall so it will not recoil upward when the pump comes on.
 - 2) Turn the **RIGHT HAND** Topside Shortening Return Lever $\frac{1}{4}$ **turn counter clockwise** and hold the hose nozzle at a 45° angle from the bottom of the vat causing sediment and debris to bounce off the rear wall and flow towards the drain valve.
 - 3) Use the “L” shaped brush to push the sediment through the drain valve to keep the drain clear. Hose off the Heat Elements and vat walls until all sediment and debris has been flushed through the drain into the filter tub.

- 4) Turn the **RIGHT HAND** Topside Shortening Return Lever $\frac{1}{4}$ **turn clockwise**; then **CAREFULLY** remove the Wash Down Hose **MALE** In-Line Plug from the **TOPSIDE FEMALE SOCKET** by depressing the Topside Socket Release Knob.
 - 5) Hang the Wash Down Hose in an up-right position so shortening can drain into a metal container; then proceed to paragraph B page 30.
- b. Fryer **WITH** an Automatic Vat Cleaner (AVC).
- 1) With the Drain Valve in the **OPEN** position, **CAREFULLY** place the AVC (Spray Blaster) on the fryer's **TOPSIDE HANGER BRACKET** and **SECURELY** connect the **MALE** In-Line Plug on the AVC flexible hose to the **TOPSIDE FEMALE SOCKET**.
 - 2) Turn the **RIGHT HAND** Topside Shortening Return Lever $\frac{1}{4}$ **turn counter clockwise** to allow shortening in the filter tub to be discharged into the vat through the four (4) nozzles in the bottom of the spray blaster, flushing sediment and debris through the drain valve. When all sediment and debris has been flushed from the vat, turn the Topside Shortening Return Lever $\frac{1}{4}$ **turn clockwise**, remove the male in-line plug on the Spray Blaster from the Topside Female Socket by depressing the Topside Release Knob.
 3. **CAREFULLY** remove the **HOT** Automatic Vat Cleaner from the hanger bracket, and **THOROUGHLY** clean it in a 3 compartment sink.
 4. Proceed to paragraph B page 30.

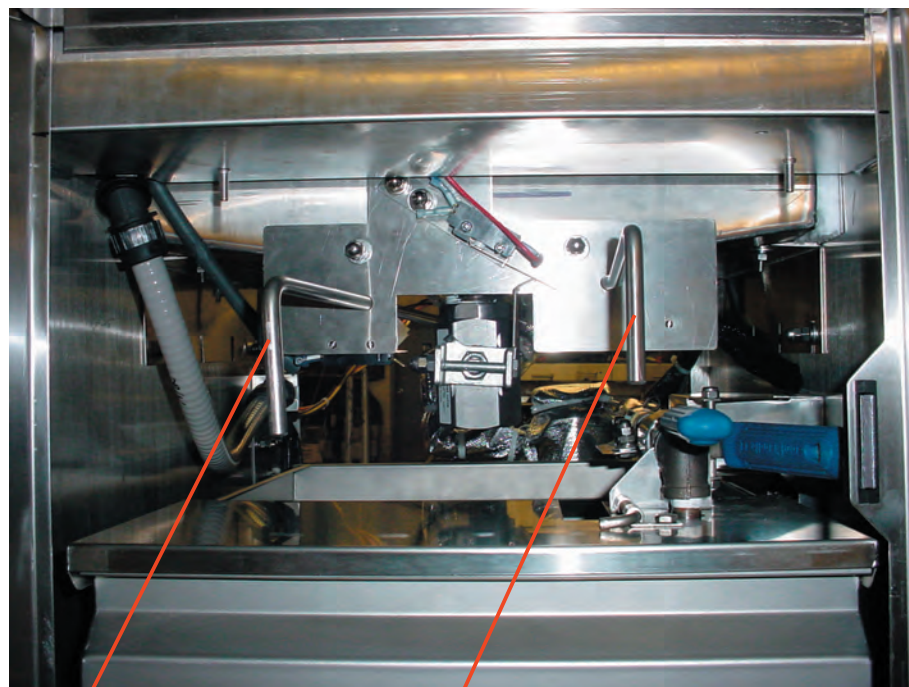

Vat Shortening
Return Lever
(Shown In Closed Position)

Topside Shortening
Return Lever
(Shown In Closed Position)

B. POLISHING SHORTENING

- 1 Set a timer for the amount of time established for **POLISHING** shortening, then turn the vat shortening **RETURN LEVER 1/4 TURN COUNTER CLOCKWISE** to allow shortening to circulate through the system and to **POLISH** the shortening.

CAUTION: DO NOT POLISH THE SHORTENING MORE THAN THE ESTABLISHED TIME AS IT WILL PUMP EXCESS AIR INTO THE SHORTENING CAUSING SHORTENING BREAKDOWN.

2. At the end of the established time, **TURN** the Vat Shortening **RETURN LEVER 1/4 TURN CLOCKWISE**, turn the **DRAIN VALVE HANDLE** to the closed **UP** position; replace the grill in the fryer; then **TURN** the Vat Shortening **RETURN LEVER 1/4 COUNTER CLOCKWISE** to automatically return shortening in the filter tub to the fryer vat.
3. When all shortening in the filter tub has been returned to the fryer, **TURN** the Vat Shortening **RETURN LEVER, 1/4 TURN CLOCKWISE** check and if necessary add fresh shortening so shortening is level with the middle line of the letter “E” in the word **LEVEL** of the shortening level mark on the rear wall of the fryer.
4. **CAREFULLY** remove the Filter Tub Assembly from the **FEMALE** Bulkhead Socket adjacent to the Drain Valve by depressing the **DOCKING RELEASE HANDLE**; then **THOROUGHLY** clean, assemble and replace the Filter Tub Assembly in the fryer cabinet.

SHORTENING DISPOSAL, FRYER BOIL-OUT& SHORTENING INSTALLATION

A. GENERAL - Shortening should be **BOILED-OUT** every **7 DAYS** to remove carbon buildup and other encrusted material.

B. SHORTENING DISPOSAL

1. **CAREFULLY** assemble the Filter Tub assembly according to paragraph A page 22 and **CAREFULLY** install it in the fryer cabinet according to paragraph B2 page 24.

CAUTION: PRIOR TO PROCEEDING TO THE NEXT STEP, PUT ON SAFETY GOGGLES, NEOPRENE INSULATED GLOVES AND AN APRON.

2. Turn the Toggle ON/OFF switch **OFF**, and ensure the filter tub is properly **DOCKED** beneath the fryer drain valve.

NOTE: Pull on the filter tub to **ASSURE** the male docking plug is **SEATED** in the female bulkhead socket.

3. Attach the Drain Valve Handle to the drain valve; then open the drain valve by turning the **DRAIN VALVE HANDLE** slightly downward. When the bottom of the filter tub is covered with about two (2) inches of shortening, completely **OPEN** the drain valve, and while shortening is draining, scrape all sides of the vat to remove encrusted material using a scraper.
4. When all shortening has drained into the filter tub, use the **DRAIN ROD** to place the wire rack on one side of the vat.
5. Use the drain rod to pull sediment on the bottom of the vat towards the drain valve opening and push it through the valve opening.
6. Use one (1) of the following procedures to **FLUSH** sediment and debris from the fryer vat:

a. Fryer **WITHOUT** an Automatic Vat Cleaner:

- 1) **CAREFULLY** connect the Wash Down Hose **MALE** In-Line Plug to the **TOPSIDE FEMALE SOCKET** and place the Wash Down Hose into the vat and hold it firmly against an inner wall so it will not “recoil” upward when the pump comes **ON**.
- 2) **TURN** the Topside Shortening Return Lever 1/4 turn counter clockwise and hold the wand hose nozzle at a 45° angle from the bottom of the fryer causing sediment and debris to bounce off the rear wall of the vat and flow towards the drain valve.
- 3) Use the “L” shaped vat brush to push the sediment through the drain valve to keep the drain clear. Hose off the burner tubes and all walls of the vat until all the sediment and residue at the bottom of the fryer has been flushed through the drain into the filter tub. Then turn the Topside Shortening Return Lever 1/4 turn clockwise.

b. Fryer **WITH** an Automatic Vat Cleaner (AVC):

- 1) **CAREFULLY** position the **AVC (SPRAY BLASTER)** on the fryer and **SECURELY** connect the **MALE** In-Line Plug on the Spray Blaster flexible hose to the **TOPSIDE FEMALE SOCKET**.
- 2) **TURN** the Topside Shortening **RETURN LEVER 1/4 TURN COUNTER CLOCKWISE** to allow shortening in the filter tub to be discharged in the vat through the four (4) nozzles in the bottom of the Spray Blaster flushing sediment and debris through the drain valve.
- 3) When all sediment and debris has been flushed from the vat, **TURN** the Topside Shortening **RETURN LEVER 1/4 CLOCKWISE** and **CAREFULLY** remove the **HOT** Spray Blaster by depressing the **TOPSIDE SOCKET RELEASE KNOB**; then **THOROUGHLY** clean the Spray Blaster in a 3 compartment sink.
- 4) **CAREFULLY** connect the Wash Down Hose **MALE** In-Line Plug to the **TOPSIDE FEMALE SOCKET**, place the Wash Down Hose into the vat and hold it firmly against an inner wall so it will not “recoil” upward when the pump comes **ON**.

7. **DISPOSE** of the shortening in the filter tub as follows:
 - a. Restaurants **NOT** equipped with a Shortening Disposal System.
 - 1) Place the Wash Down Hose **NOZZLE** into a **METAL** container and hold it firmly against an inner wall.
 - 2) **TURN** the **TOPSIDE SHORTENING RETURN LEVER 1/4 TURN COUNTER CLOCKWISE** and pump shortening into the metal container.
 - 3) When all shortening has been pumped into the container, **TURN** the **TOPSIDE SHORTENING RETURN LEVER 1/4 TURN CLOCKWISE**, remove the Wash Down Hose from the **TOPSIDE FEMALE SOCKET** and hang the hose in an upright position so shortening in the hose can drain into a container.
 - b. Restaurants equipped with a Shortening Disposal System.
 - 1) **SECURELY** connect the Shortening Disposal Hose fitting to the **TOPSIDE FEMALE SOCKET** and connect the fitting on the other end of the hose to the Disposal System connector on the wall.
 - 2) **TURN** the **TOPSIDE SHORTENING RETURN LEVER 1/4 TURN COUNTER CLOCKWISE** and pump shortening in the filter tub into the Exterior rendering tank.
 - 3) When all shortening has been pumped into the rendering tank, **TURN** the **TOPSIDE SHORTENING RETURN LEVER 1/4 TURN CLOCKWISE**, remove the Disposal Hose from the **TOPSIDE FEMALE SOCKET**.
Hang the hose in an upright position so shortening in the hose can drain into a container.
8. **THOROUGHLY** clean and re-assemble the filter tub.
- C. **BOIL-OUT** - Boil-out the fryer following the cleaning instructions in the Cleaning Manual provided by your approved chemical supplier. The following are generic procedures:

DTMR EQUIPPED FRYER

1. Ensure the Drain Valve Handle is in the closed (UP) position, then add water to the fryer vat until it reaches a point one (1) inch (25 mm) **BELOW** the middle line of the "E" in the word **LEVEL** on the rear wall of the fryer.
 2. Add the amount of **BOIL-OUT COMPOUND** to the fryer vat as prescribed in the Cleaning Manual provided by the Chemical Supplier.
 3. Turn the Toggle Switch for the fryer to the **ON** position, depress and release the **START** button; then depress and release the **EXIT MELT** button on the DTMR.
 4. When the boil-out solution starts to **BOIL** set a timer for 30 minutes and frequently scrub the sides, front and back of the vat with a long handled scrub brush.
- NOTE:** If the boil-out solution starts to boil over, shut the fryer **OFF** for a few minutes and add water as necessary, then turn it back **ON**.
5. While the fryer is being **BOILED OUT**, clean the filter tub assembly according to procedures in the cleaning section.
 6. When the timer sounds, turn the Toggle ON / OFF Switch for the fryer to the **OFF** position and **CAREFULLY** dispose of the boil-out solution in the fryer in a floor drain.
 7. Use a scrubbing pad to remove carbon build-up from the top of the heat elements. To remove carbon build-up on the sides and bottom of the heat elements, slide one end of a stropping pad under each heat element, grasp that end with a pair of tongs and rock the pad up and down along the length of each heat element until all encrusted material has been removed. Replace the wire rack in the fryer.
 8. Rinse the fryer with hot water until the water coming out of the drain valve is clear.
 9. Mix a solution of **ONE PART** vinegar to **25 PARTS** of water. Place this mixture into a one-gallon garden pressure sprayer and **THOROUGHLY** spray this solution onto the **SIDES, HEAT ELEMENTS** and **BOTTOM** of the fryer to neutralize the Boil-Out Compound.
- NOTE:** Boil-Out Compound will cause shortening to break down rapidly if it is not neutralized.
10. **THOROUGHLY** wipe the sides, heat elements and bottom of the fryer with clean, lint-free, dry towels to remove any remaining water, turn the **DRAIN VALVE** to the closed UP position; then fill the fryer with **NEW** shortening to the shortening level mark as described in paragraph D on the next page.

D. SHORTENING INSTALLATION

1. **LIQUID SHORTENING:** When using liquid shortening (cooking oil) fill the fryer with shortening even with the middle line of the “E” in the word **LEVEL** of the shortening level mark on the rear wall of the fryer.
2. **SOLID SHORTENING:**
 - a. Cut a block of solid shortening into small pieces.
 - b. Place small pieces of solid shortening **EVENLY** on top of the **HEAT ELEMENTS** or **THOROUGHLY PACK** these pieces of solid shortening between, below and above the **HEAT ELEMENTS**. While packing solid shortening is messy and time consuming, it is the safest and fastest way to melt solid shortening.
 - c. DTMR equipped Fryer
 - 1) Turn the fryer Toggle switch **ON**; then place the Default-to-Manual-Restart (DTMR) Control in the **SHORTENING MELT MODE** by depressing then releasing the momentary **START** button on the DTMR. The **RED START** lamp and **AMBER MELT MODE** lamp will light to indicate the fryer is in the melt mode.
 - 2) When the **HEAT ELEMENTS** are **COMPLETELY** covered with **LIQUID** shortening and the shortening is heated, replace the grill in the fryer vat; then push the **EXIT MELT** button on the DTMR and proceed to paragraph d below.
 - d. Continue adding solid shortening as follows:
 - 1) Place small pieces of solid shortening into a fry basket.
 - 2) **CAREFULLY** lower the basket into the fryer vat.
 - 3) **GENTLY** turn the basket to allow these pieces of solid shortening to float away.
 - 4) Repeat the above steps until liquid shortening is even with the middle line of the “E” in the word **LEVEL** of the shortening level mark on the rear wall of the fryer vat.

**WARNING!!!
TO AVIOD INJURY**

- I DO NOT MOVE A FRYER FILLED WITH HOT LIQUID.
- II ALWAYS WEAR OIL-PROOF, INSULATED GLOVES WHEN WORKING WITH A FRYER FILLED WITH HOT OIL.
- III ALWAYS DRAIN HOT OIL INTO A METAL TUB, POT OR CAN ... HOT OIL CAN MELT PLASTIC.

TECHNICAL ASSISTANCE - Contact an authorized service agent or the Customer Service Department, Ultrafryer Systems at 1-800-525-8130 for technical assistance.

A. ORDERING INFORMATION:

1. **REPLACEMENT PARTS** - Provide the following information when ordering replacement parts by phone, fax or mail:

Your company name and phone number
Your company purchase order number
Bill-to address
Ship-to address
Quantity desired
Part number and description of the desired-item
Your name or signature of authorized-buyer
Phone in order to: 1-800-545-9189 Ext 5029
FAX order to: 1-210-731-5099
Mail order to: Ultrafryer Systems
Order Entry Office
P.O. Box 5369
San Antonio, TX 78201
E-Mail your order to: Ultrafryerservice@ultrafryer.com

2. **TERMS** - Net 30 days for customers on approved accounts. Past due balances will be charged 1% per month (12% per annum) until full balance is paid.
3. **DAMAGES** - Ultrafryer Systems is not responsible for damage occurring in transit. All deliveries must be inspected for damage to shipping containers prior to departure of the delivering carrier. Any damage must be notated on the receiving document to facilitate filing of freight claims. Carriers must be notified immediately and freight inspections must be requested from the carrier. Ultrafryer Systems can and will gladly assist you in preparing and processing of the necessary claims only if proper notification has been accomplished on the carrier delivery document. Damaged equipment and or containers must be available for the claims inspector to inspect.
4. **RETURNS** - Ultrafryer Systems cannot guarantee credit for items returned without proper authorization. All returns must have prior Ultrafryer Systems Customer Service or Warranty department approval. An assigned number will be issued by the approval authority. Please print the assigned number on all returned packages and corresponding paperwork. Returned goods are subject to a 15% restocking charge. Ultrafryer Systems is not responsible for freight charges on returned goods unless authorized by Customer Service and or Warranty personnel. Ultrafryer Systems does not receive freight collect or C.O.D. shipments.

- B. PARTS IDENTIFICATION** - Locate the part on the following sketches and note the index number i.e, 3, 6, etc; then obtain the part number and description for that index number on the page facing the sketches. Use that part number when ordering a replacement part.

ULTRAFRYER MODEL EUHE
18" ELECTRIC FRYER

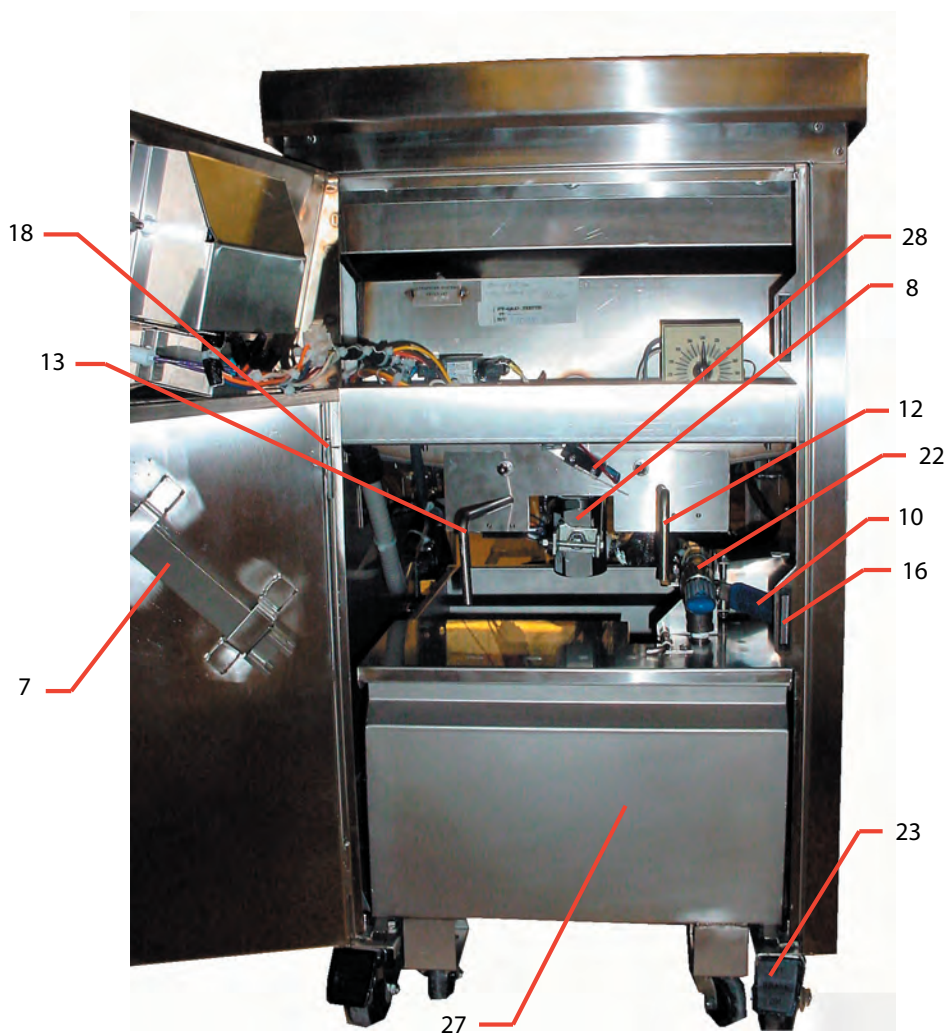
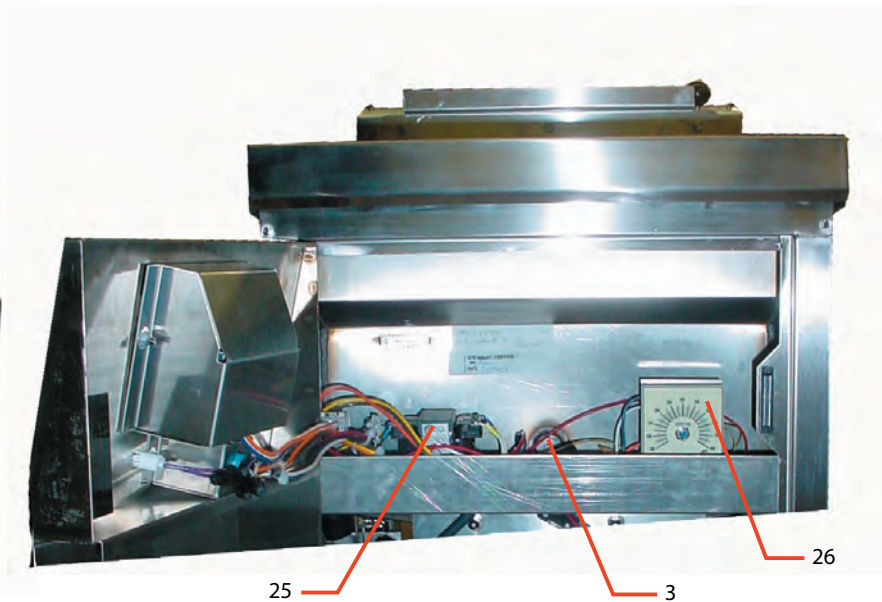
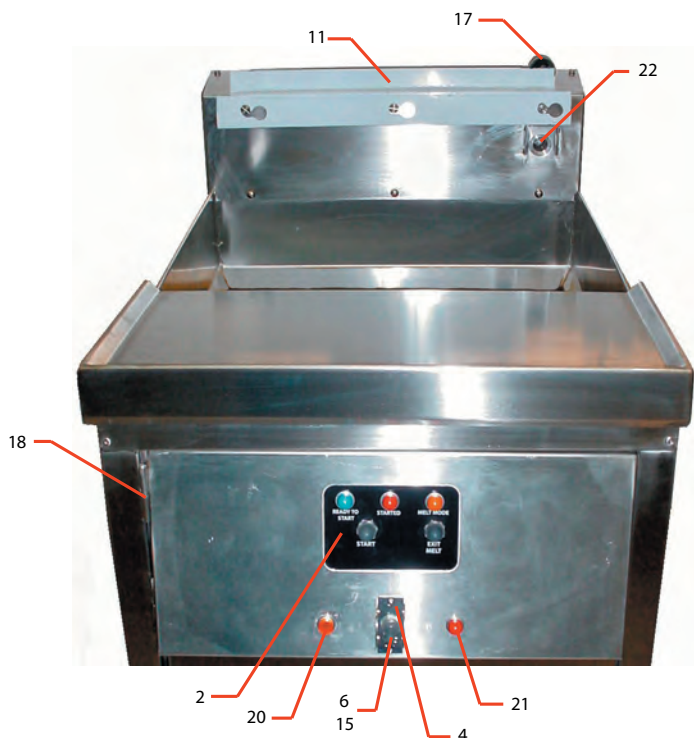

	ITEM	DESCRIPTION	PN
*	1	Drain Clean-Out Rod	12569
	2	Default-To-Manual-Restart (DTMR) Control	12B069
	3	Electronic Thermostat Temperature Probe	18A276
	4	On/Off Toggle Switch Guard	18129
*	5	Proximity Sensor Switch	18A060
	6	120 Volt 6 AMP SPDT Toggle Onn/Off Switch	18A287
	7	Drain Ball Valve Handle	19A558
	8	1 1/4" (32mm) Drain Ball Valve Assembly	19A564
*	9	High Limit Switch Probe Perforated Holder	19A788
	10	Docking Release Handle	19A948
	11	Basket Hanger Bracket	19A950
	12	Topside Shortening Return Lever	19B242
	13	Vat Shortening Return Lever	19B493
*	14	Chrome Door Pull Handle	22005
	15	Toggle On/Off Switch Protective Boot	22402
	16	Magnetic Door Catch	22407
	17	1 3/8" (34mm) Black Plastic Knob	22620
	18	Lift-Off Door Hinge	22640
*	19	17 1/2" (445mm) X 17 9/16" (446mm) Vat Grill	22704
	20	24 Volt 1/3 Watt Snaplight w/ AMBER Lens	23A101
	21	24 Volt 1/3 Watt Snaplight w/ RED Lens	23A103
	22	1/2" (13mm) FPT S/S Female Bulkhead Socket w/ Raised Push Button Release	24A209
	23	Medium Duty 3" (76mm) Front Caster w/ Brake	28A010
*	24	"L" Shaped Tip Cleaning Brush	29A044
	25	Type K 120 to 24 Volt 100 KVA Square D	18A010
	26	Electronic Thermostat	12B077
	27	Filter Tub Assembly (Shown Docked)	12B299
	28	Drain Valve MircoSwitch	18185

* NOT SHOWN

ULTRAFRYER MODEL EUHE
ELECTRIC FRYER
REAR VIEW

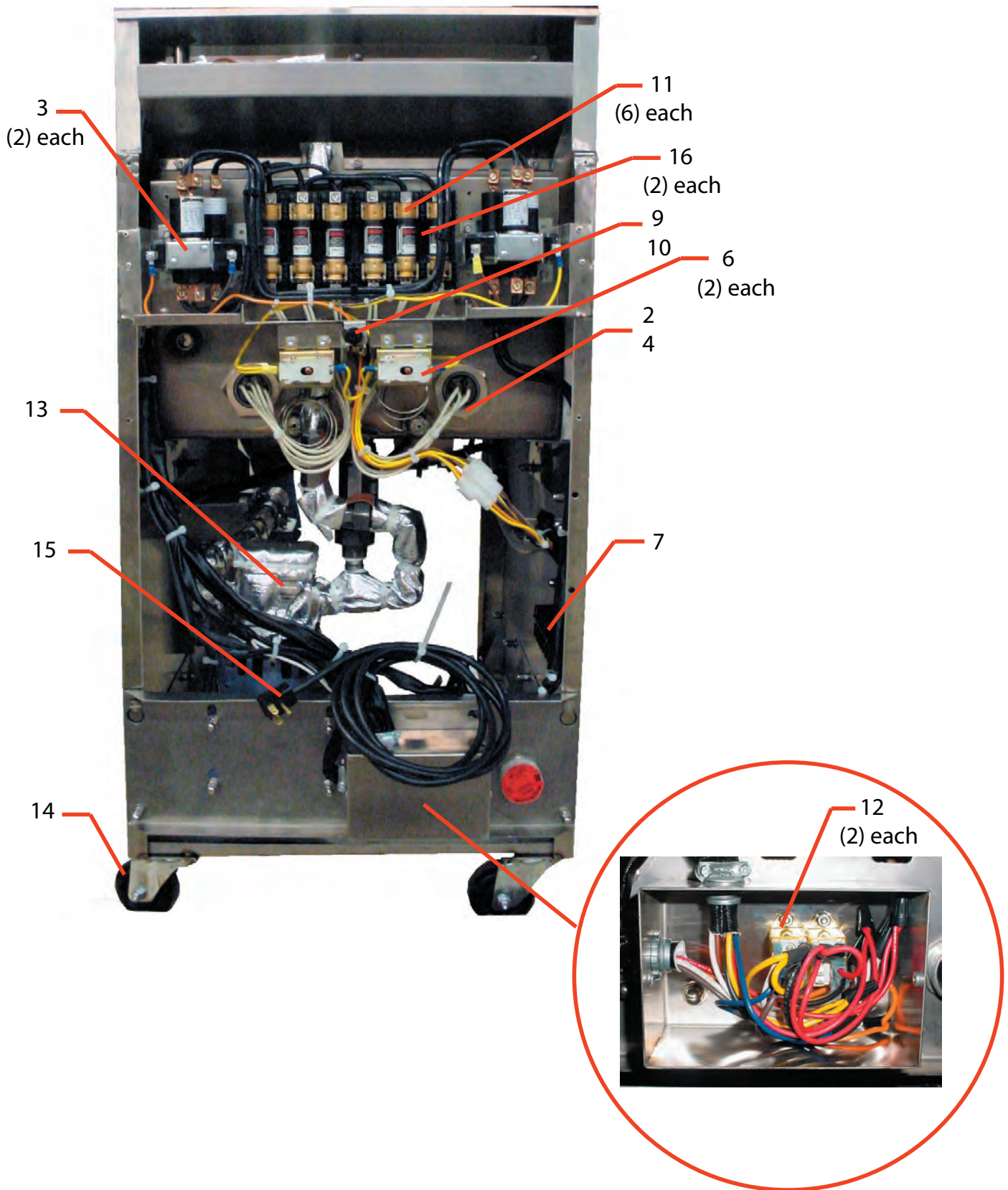

ITEM	DESCRIPTION	PN
1	Watlow Heat Element Wrench	12312
2	Heat Element Teflon washer ** DO NOT SUBSTITUTE**	18174
3	208/240 Volt 3 Phase 60 Amp Mercury Contactor w/ 24 Volt Resistive Coil	18231
4	208 Volt 3 Phase 10 KW Heat Element F/ 18" and 20" Electric Fryer	18A013
	240 Volt 3 Phase 10 KW Heat Element F/ 18" and 20" Electric Fryer	18A015
5	Proximity Actuator Sensor	18A059
6	Hi-Limit Switch Preset to Trip at 450°F (232°C). **NOTE** Order a 1/4" (6mm) Compression Fitting PN 24247 When Ordering This Switch	19A145
7	High Voltage Terminal Block	22544
8	125 Volt 75 Watt Silicone Heater Tape 5' (1524mm) Long (Beneath Insulation Flex weave)	23341
9	Type AP-2 Fuse Holder Assembly	23373
10	Buss Type AGC-8 8 Ampere Fuse	23374
11	Class RK 5 250 Volt 35 Ampere Time Delay Fuse F/ 18" and 20" Electric Fryer	23A043
12	120 Volt 50/60 Hz Shortening Return Relay	18A020
13	Model GPV-0519 7.7 GPM (29.26 lpm) Viking Pump/Motor **NOTE** For Pump Only Order PN 24329 and for Motor Only Order PN 17A018	24A207
14	Medium Duty 3" (76mm) Rear Caster W/O Brake	28A011
15	Type SJO 16/3 Electrical Cord w 90° Molded Electrical Plug	33048
16	Fuse Block F/ 35 Ampere Time Delay Relay Fuse	23A044

* NOT SHOWN

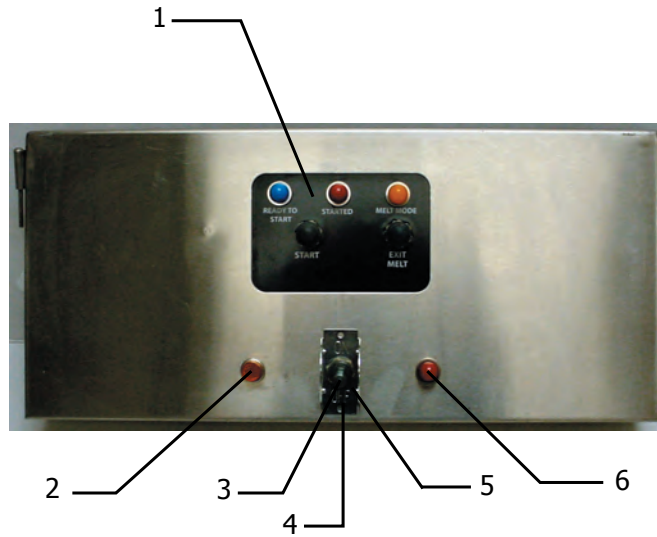

ITEM	DESCRIPTION	PN
1	COOKING CONTROLS Default-To-Manual-Restart (DTMR) Control f/ 18" Model EUHE Electric Fryer. Uses Electronic Thermostat PN 12B077	12B069
2	24 Volt 1/3 Watt Snaplight w/AMBER Lens	23A101
3	120 Volt 6 Amp SPDT Toggle ON/OFF Switch.	18A287
4	Toggle ON/OFF Switch Protective Boot.	23402
5	Toggle On/Off Switch Guard	18129
6	24 Volt 1/3 Watt Snaplight w/RED Lens	23A103

**ELECTRONIC THERMOSTAT
PN 12B077**

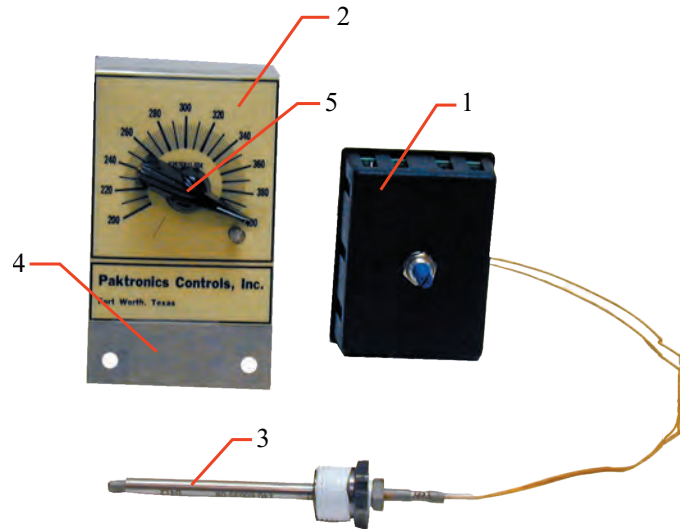

ITEM	DESCRIPTION	PN
1	Electronic P14 Thermostat	18A058
2	Electronic Thermostat Face Plate	18A070
3	Temperature Probe	18A276
4	Electronic P14 Thermostat Bracket	19B174
5	Electronic Thermostat Knob	22A169

EUHE HARD DOCK FILTER TUB ASSEMBLY
18" With Micromesh Filter PN 12B299

	ITEM	DESCRIPTION	PN
*	1	Filter Tub Scraper	12567
	2	Micromesh s/s Filter Screen Assembly with StandPipe & Docking Assembly	12B113
	3	Wash Down Hose Assembly	12B115
	4	Filter Tub cover with hinge latch and Proximity sensor actuator for 14" Filter Tub	19B309
*	5	Proximity Actuator Sensor	18A059
	6	18" Model Filter Tub	19B309
	7	18" Model Crumb Catcher Screen	19B308
	8	RH S/S Hinge Latch	22479
	9	Medium Duty Caster	28A005

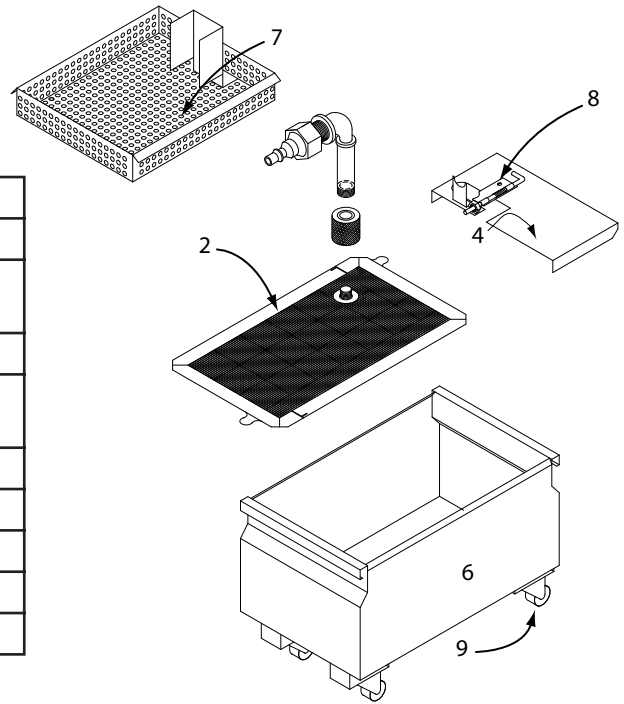

* NOT SHOWN

WASH DOWN HOSE ASSEMBLY
PN 12B115

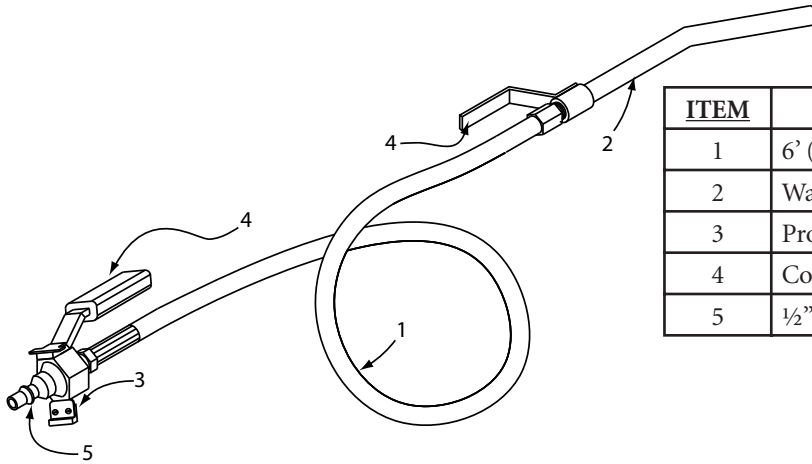

ITEM	DESCRIPTION	PN
1	6' (1829mm) Wash Down Hose w/Fittings	12541
2	Wash Down Hose & Nozzle Assembly	12675
3	Proximity Sensor Actuator	18A059
4	Cool II Handle	22734
5	½"(13mm) S/S Locking Seal Inline Plug	24A208

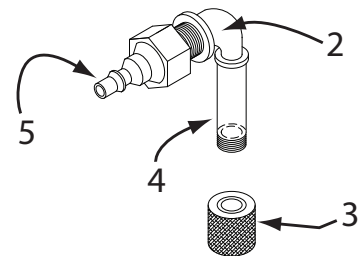

ITEM	DESCRIPTION	PN
1	Micro-Mesh S/S Filter Screen	21A278
2	½"(13mm) xa" (10mm) 90° Black Iron Elbow	24A201
3	Top Compression Cap (Knurl Knob)	24369
4	½"(13mm) x 7" (178mm) Black Iron Nipple	24471
5	½"(13mm) S/S Locking Seal Inline Plug	24A208

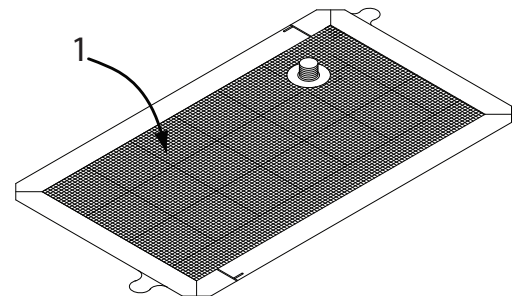

MICRO-MESH FILTER ASSEMBLY
WITH STANDPIPE & DOCKING ASSEMBLY
PN 12B113

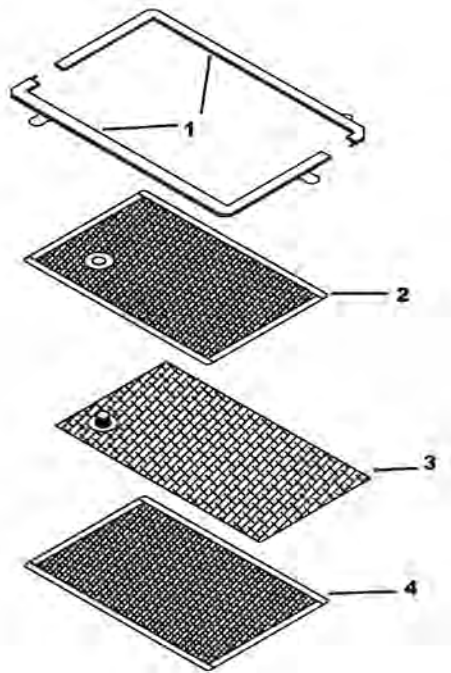

FILTER SCREEN ASSEMBLY		
ITEM	DESCRIPTION	PN
1	Replacement Frame Set	21A284
2	Replacement "Upper" Screen	21A285
3	Replacement Baffle Assembly	21A286
4	Replacement "Lower" Screen	21A287

**ULTRAFRYER MODEL EUHE ELECTRIC FRYER
AUTOMATIC VAT CLEANER W HOSE ATTACH
18" PN 12B493**

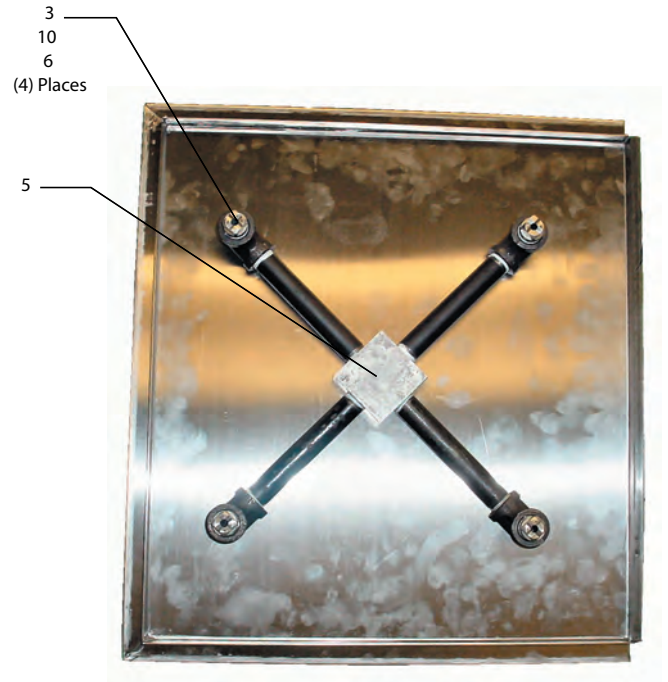
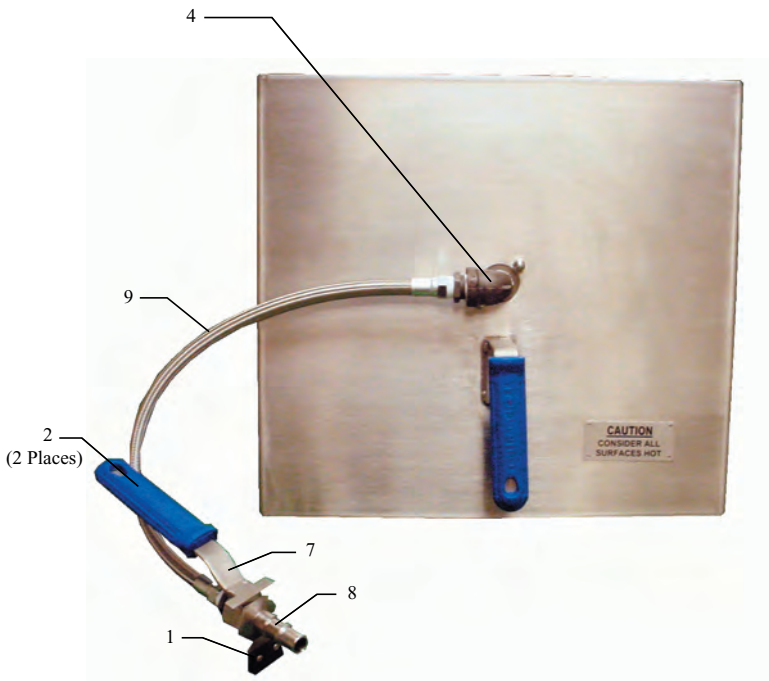

<u>ITEM</u>	<u>DESCRIPTION</u>	<u>PN</u>
1	Proximity Actuator Sensor	18A059
2	Cool II Handle	22-734
3	½" (13mm) HH-2236 SQ Spray Nozzle	22A111
4	½" (13mm) x 90° Black Iron Street Elbow	24-256
5	½" (13mm) 5 Way Black Iron Crossover Manifold	24A082
6	½" (13mm) x 5 w" (146mm) Black Iron Nipple	24A100
7	Handle Assy, P3H Weld Coupling Male	19B242
8	½" (13mm) S/S Locking Seal In-Line Plug	24A208
9	½" (13mm) x 21" (533mm) AVC Flexible Shortening Line	24A220
10	½" (13mm) x 90° Black Iron Elbow	24-007

WIRING DIAGRAMS

NOTE: Since minor changes may occur in the future,
 USE the diagram attached to the fryer for circuit
 tracing and/or troubleshooting

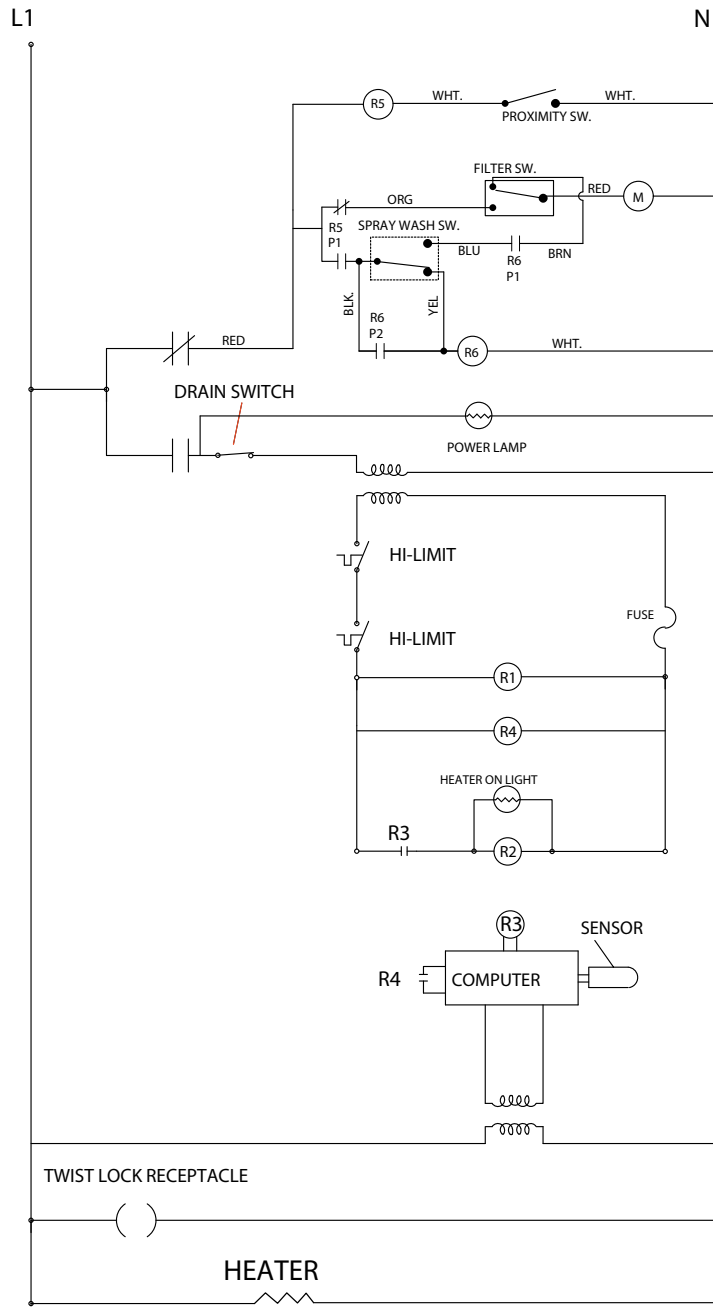

208 V. 3Ø
 OR
 240 V. 3Ø /

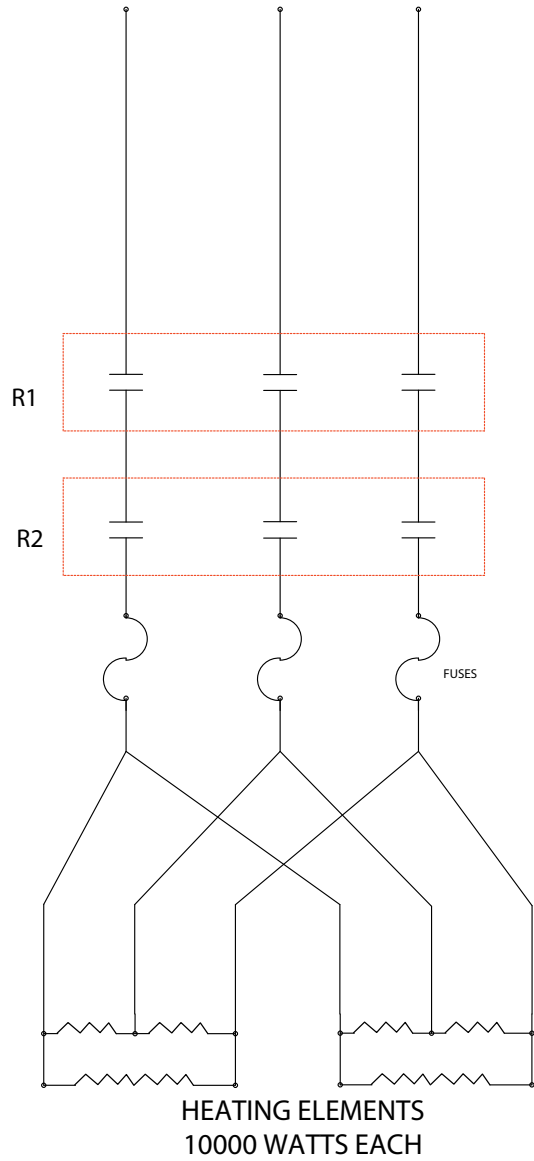

18IN EUHE Electric Fryer With Computer

NOTE: Since minor changes may occur in the future,
USE the diagram attached to the fryer for circuit
tracing and/or troubleshooting

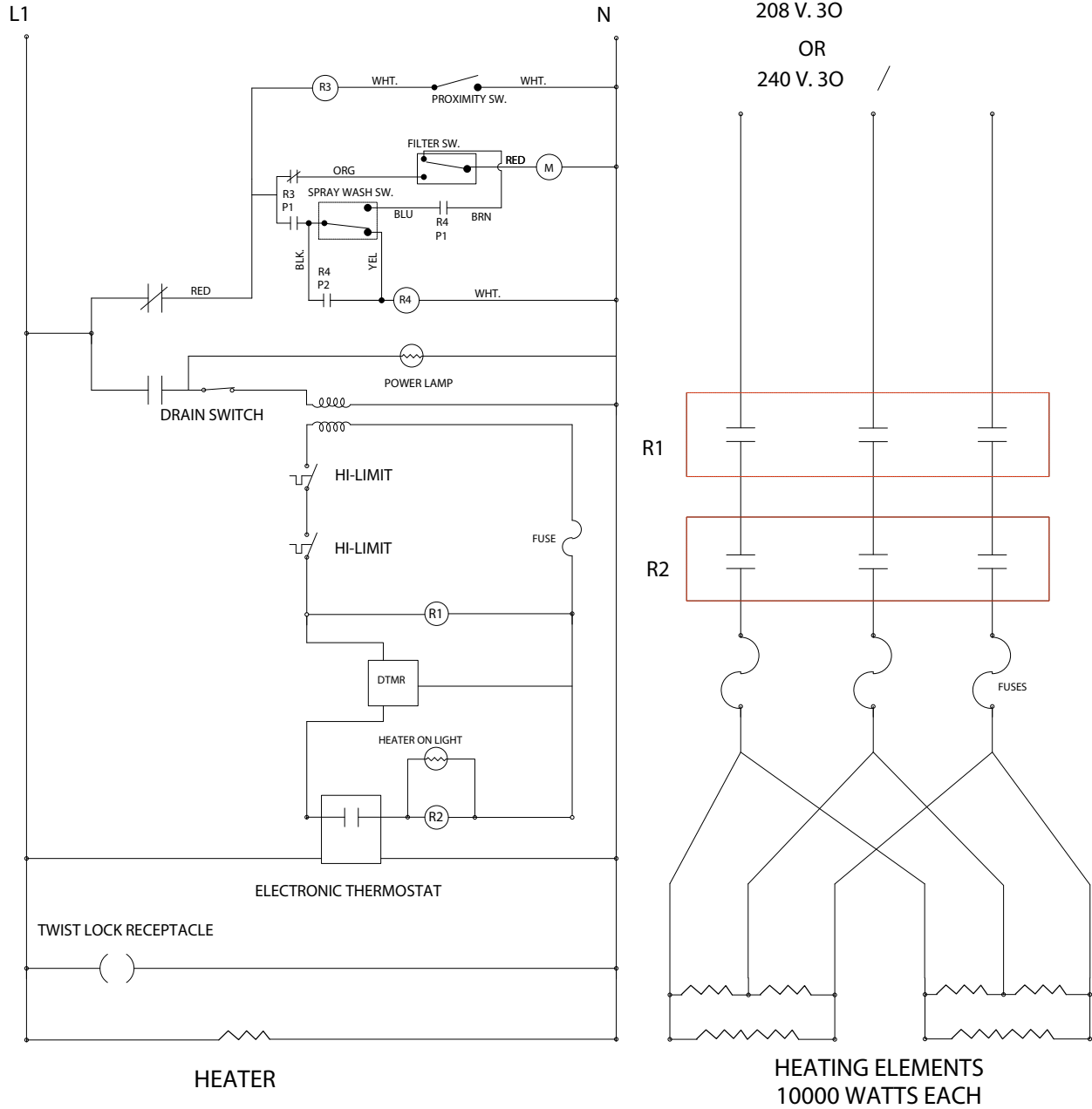

18" EUHE Electric Fryer With DTMR

THIS PAGE INTENTIONALLY LEFT BLANK