



PAR-3-18-TL Gas Fryer Operating Instructions



WARNING!! TO ASSURE PRODUCING A QUALITY PRODUCT WHILE PROLONGING THE LIFE EXPECTANCY OF THE FRYER, ENSURE FILTERING, BOIL-OUT AND CLEANING INSTRUCTIONS ARE STRICTLY ADHERED TO.

302 Spencer Lane • P.O. Box 5369

San Antonio, Texas 78201

(800) 525-8130 • (210) 731-5000 • Fax: (210) 731-5099

www.ultrafryer.com

PREFACE

This Manual was written and published by the Engineering Department, Ultrafryer Systems for use by personnel who will operate a Model PAR-3-18-TL Gas Fryer equipped with a Default-To-Manual-Restart (DTMR) Controller in a commercial cooking environment.

ENGINEERING DEPARTMENT
ULTRAFRYER SYSTEMS
302 SPENCER LANE
SAN ANTONIO, TX 78201

This manual is to be used for all variations of a PAR-3-18-TL fryer banks.

UFS PN 30A077
Revision 1/19/05

TABLE OF CONTENTS

GENERAL INFORMATION	PAGE
Warranty.....	2
Safety.....	3
Description / Specifications.....	3
Optional Accessories.....	3
Operating Controls Location.....	4
Operating Controls.....	5
Rating Plate.....	5
Inlet Gas Line Sizing.....	6
Inlet Gas Requirements.....	7
PRE-INSTALLATION	
General.....	9
Standards.....	9
Air Supply & Ventilation.....	9
RECEIVING & INSTALLING	
Unpacking.....	11
Installing.....	11
Leveling.....	15
Gas Connection.....	16
Flexible Couplings, Connectors.....	16
Fryer Service.....	16
Electrical Connection.....	16
Default-To-Manual-Restart (DTMR) Control.....	17
Optional Controls.....	17-18
INITIAL START-UP	
General.....	20
Start-Up.....	20
Lighting Instructions.....	20
Sequence Of Ignition.....	20
Burner Operation Test.....	20
Shortening Installation.....	20
Start-Up.....	21-22
ABBREVIATED OPERATING INSTRUCTIONS	
General.....	24
Filtering Shortening.....	24
Leveling Shortening.....	24
Boiling Out Fryer.....	24
Closing / Shutdown Instructions.....	24
Cleaning.....	24-25

TABLE OF CONTENTS.....Continued

	PAGE
ELECTRONIC THERMOSTAT CALIBRATION	
General	27
Electronic Thermostat Calibration	27
PREVENTIVE MAINTENANCE & TROUBLESHOOTING	
Preventive Maintenance	29
Troubleshooting	29
Troubleshooting Chart	30
CLEANING	
General	32
Daily	32-33
Weekly	33-34
FRYER OPERATION	
General	36
Cooking	36
Test Start-Up and Cooking	36
DTMR Operation	37
FILTER TUB ASSEMBLY & INSTALLATION	
General	39
Filter Tub Assembly	40
Filter Tub Installation	40
FILTERING & POLISHING SHORTENING	
General	42
Filtering Shortening	42
Polishing Shortening	43
SHORTENING DISPOSAL, BOIL-OUT & INSTALLATION	
Shortening Disposal	45-46
Fryer Boil-Out	46-47
Shortening Installation	47-48
TECHNICAL ASSISTANCE & ORDERING INFORMATION	
Technical Assistance	50
Ordering Information	50
RECOMMENDED SPARE PARTS	52
PARTS IDENTIFICATION	
Parts Identification	54-63
WIRING DIAGRAM	65

GENERAL INFORMATION

A. WARRANTY

ULTRAFRYER® LIMITED WARRANTY

Ultrafryer Systems warrants to the original purchaser of a gas or electric Ultrafryer® sold within the United States, its territories and Canada, that it will be free of defects in material and workmanship for the periods listed below:

STAINLESS STEEL FRYER VAT – Stainless Steel fryer vats are warranted for (10) ten years upon the terms hereinafter described. The (10) ten year warranty coverage applies ONLY to the Stainless Steel fryer vat and does not apply to the other components such as controls, fire boxes, gaskets, mounting hardware, or the heat shield weldment. The (10) ten year limited warranty coverage for the Stainless Steel fryer vats are as follows: (1) Vats that fail due to faulty workmanship or materials within the first twelve (12) months from the date of initial start up will be exchanged at no cost. Standard delivery ground freight will be prepaid by Ultrafryer Systems **for first year failures only**. The cost of labor to install the replacement vat will be covered by Ultrafryer Systems for vats, which fail within twelve (12) months from the date of initial start up. Labor for vat replacements after the first year is the responsibility of the owner. (2) Vats that fail within the second year will be exchanged at \$150.00 FOB San Antonio. (3) Vats that fail within the third through fifth year will be exchanged at a \$200.00 FOB San Antonio. (4) Vats that fail within the sixth through eighth year will be exchanged 50% of current selling price of said vat FOB San Antonio. (5) Vats that fail within ninth through tenth year will be exchanged at 70% of the current selling price of said vat FOB San Antonio. (**Example:** If the current selling price of a vat is \$1,000.00, then during the sixth through eighth year it would be exchanged for \$500.00; in the ninth and tenth years it would be exchanged for \$700.00). (Subject to inflation adjusted in accordance with the C.P.I.). Proper credit issue for vat failures is contingent upon receipt, by Ultrafryer Systems, of the serial number identification tag for any failed vat.

ULTRAFRYER PARTS – All parts on the Ultrafryer® are covered for a period of one (1) year from the initial date of start up. This is to include computers, gas valves, switches, thermostats, etc. Ultrafryer Systems reserves the right to charge for certain parts such as computers, filter pumps and motors or any item over the amount of \$100.00 until Ultrafryer Systems receives the defective part back. After inspection, credit for the part will be issued to the purchaser provided the part is deemed defective and that defect is not the result of neglect or abuse by the user. The shortening filtration system, (hoses) are warranted for ninety (90) days from the initial date of start up.

PROCESSING WARRANTY CLAIMS – The equipment owner must promptly notify Ultrafryer Systems Warranty Department of any alleged defects as soon as they are discovered by calling 1-800-525-8130. After such notice, the Warranty Department will perform its obligation under this warranty within a commercially reasonable period of time. If alleged defects develop after normal business hours, on weekends or on holidays the owner must call Ultrafryer Systems first at the above number. This number is monitored 24 hours a day, 7 days a week. Ultrafryer Systems will notify an authorized service agent to make repairs during normal hours or after hours. Any parts that need to be shipped back to Ultrafryer Systems will be shipped back **prepaid by the customer** marked with the processing number and to the attention of the WARRANTY DEPARTMENT.

NON WARRANTY COVERAGE – This warranty does not include coverage for any consequential cost of damages including, but not limited to, any loss in store sales, spoiled food products, transportation, duty or custom cost. This warranty does not cover the Ultrafryer® exported to countries outside the United States and its territories. This warranty does not cover original installation and adjustments such as leveling, calibrations, electrical and gas connections, or problems due to faulty or contaminated gas supply. This warranty does not cover travel over 100 miles or 2 hours driving time from the location of the Ultrafryer® or overtime or holiday charges unless the Warranty Department granted prior approval. This warranty does not cover damage due to misuse, abuse, alteration or accident. This Warranty does not cover improper or unauthorized repair or installation, damage in shipment, normal maintenance items such as gaskets, hoses, and exterior finishes. **Ultrafryer Systems reserves the right to void component part warranty on any Ultrafryer® that is stored more than 6 (six) months after shipment from Ultrafryer Systems and not put into service.**

LABOR COVERAGE – The cost for labor to replace parts are covered for one (1) year after the initial start up. This warranty will include the labor involved in the six (6) month and the twelve (12) month fryer inspections recommended by the manufacturer for the first year after initial start up. **The Warranty Department must be promptly notified of any defects within the first year of operation.** The labor warranty does not include the cost to repair or clear dirty filter systems or perform any adjustments that would normally fall under the tasks associated with a proper start up and/or demonstration. **Labor is covered by Ultrafryer Systems for repairs by an AUTHORIZED service agent.** Owner is responsible for all costs associated with fryer installation and start up unless prior arrangements have been made with Ultrafryer Systems.

DISCLAIMER OF WARRANTIES

Other than as stated herein ULTRAFRYER SYSTEMS makes no warranty of any kind, express or implied, including but not limited to any warranty of merchantability of fitness for a particular purpose, including trade usage. Ultrafryer Systems sole obligation, and purchaser's sole remedy, under this warranty is repair or replacement, at the discretion of Ultrafryer Systems, of any part or component that proves to be defective in materials or workmanship. In no event shall Ultrafryer Systems be liable for consequential, incidental, or special loss or damages arising from the use of, or inability to use, the ULTRAFRYER®. This limited warranty is the only and complete statement with respect to warranties of NEW Ultrafryer® PAR-2, PAR-3 Gas and Electric ULTRAFRYERS® sold after March 1st, 2001. There are no other documents or oral statements for which Ultrafryer Systems will be responsible.

B. SAFETY

The major safety concern associated with the Ultrafryer Par-3-18 Gas Fryer Bank is burns from hot shortening. In order to prevent serious burns, good housekeeping habits are required. The floor in front of and the area around the fryer should be kept clean and dry. Whenever anything is placed into a fryer vat, care should be used not to splash the hot shortening. Product should always be “PLACED” into the shortening, not thrown. Safety goggles, neoprene insulated gloves and an apron must be worn while filtering or boiling-out a fryer vat. Electrical controls on all Ultrafryer Fryers operate on 120 volts single phase electrical power. No adjustments or replacement of electrical controls should ever be attempted without first disconnecting electrical power. The fryer should never be operated with wet hands or while standing in water. To do so can result in serious electrical shock or death. The Par-3-18 Gas Fryer Bank is equipped with the following safety features:

- 1) High Limit Thermostat to shut off gas to the burners by opening a solenoid- actuated safety valve in the combination gas control valve.
- 2) Combination gas control valve which includes a built-in pressure regulator and manual valve.
- 3) An AIR PRESSURE switch to open the 24 Volt electrical circuit to the Combination Gas Control Valve, should the Blower Motor fail, turning gas to the fryer OFF.
- 4) Sensing circuit within the Spark Ignitor Module to turn the fryer OFF if a burner FLAME-OUT occurs and, 5) A Drain Valve Safety Switch that will DISABLE the fryer each time the shortening drain valve is OPENED.

C. DESCRIPTION/SPECIFICATIONS

The Ultrafryer Par-3-18 Gas Fryer Bank is constructed from 16 and 18 gauge, type 304 polished satin finish stainless steel. Each bank of gas fryers is equipped with a Default-To-Manual-Restart (DTMR) Control, a work station with a pedestal type Hatco warmer lamp and a shortening filtration system that uses a Paper Filter Envelope. The Customer has the option of ordering a Magnepad Filter System that uses a Magnesol Impregnated Filter Pad, a paper filter pad or a Stainless Steel filter screen. The dimensions, specifications and gas rating of PAR-3-18 Fryer are as follows:

ITEM DESCRIPTION	PAR-3-18-TL	
	USA	Metric
Overall Width	19 ½"	(495)
Overall Depth	36 ¾"	(933)
Work Height	36"	(914)
Oil Capacity		
High Level	110 lbs	(55 liters)
Low Level	70 lbs	(35 liters)
Size Vat Container	18" x 18" (457 x 457)	
Gas Rating		
Butane Gas	110,000 BTU/Hr (116 MJ/Hr.)	
Natural Gas	110,000 BTU/Hr (116 MJ/Hr.)	
Propane Gas	110,000 BTU/Hr (116 MJ/Hr.)	
Shipping Cube	17.15 ft ³	(.48 m ³)
Shipping Weight	315 lbs	(142 kgs)
Electrical Requirements	120 VAC 6 Amps 60 Hz 1 Ø	

D. OPTIONAL ACCESSORIES

- A. Hatco Warmer Overshelf - This fryer also may be equipped with an optional Hatco Warmer Overshelf. SEE manual PN 30A149, Hacto Warmer Overshelf Installation instructions included with the applicable fryer.
- B. Automatic Basket Lift- This fryer also may be equipped with an Automatic Basket Lift system SEE manual PN 30A081, Automatic Basket Lift System Installation/Operation instructions included with the applicable fryer.

E. OPERATING CONTROLS LOCATION

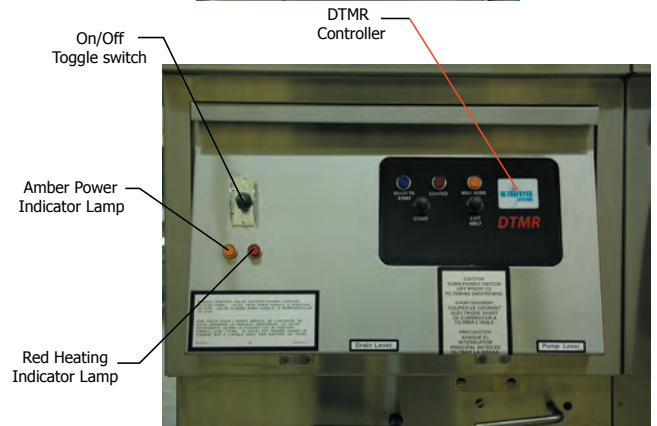
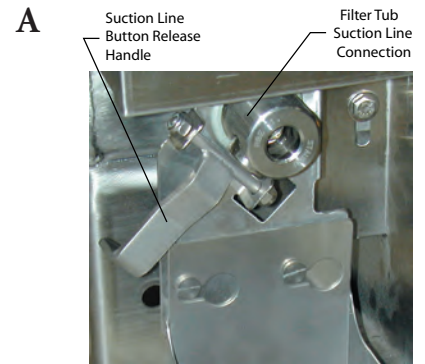
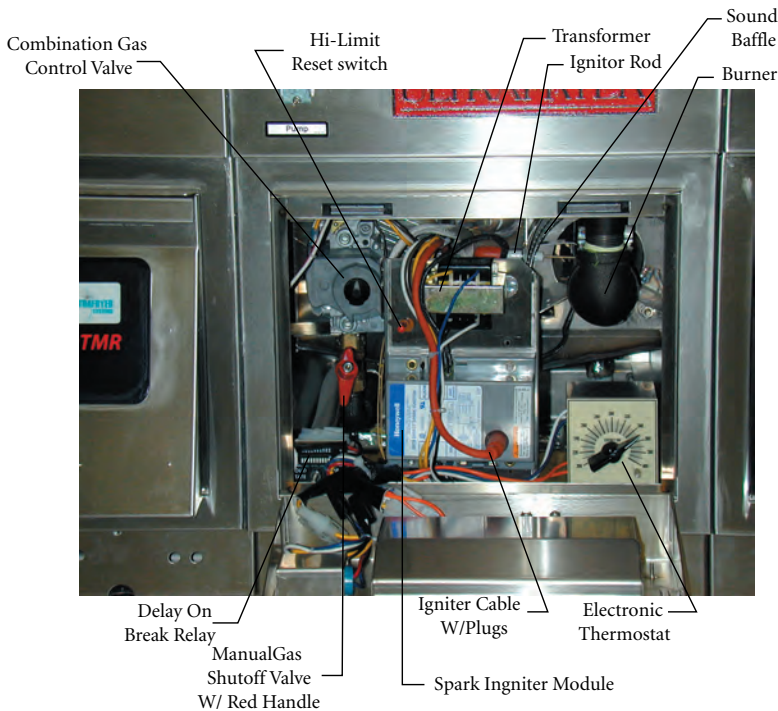
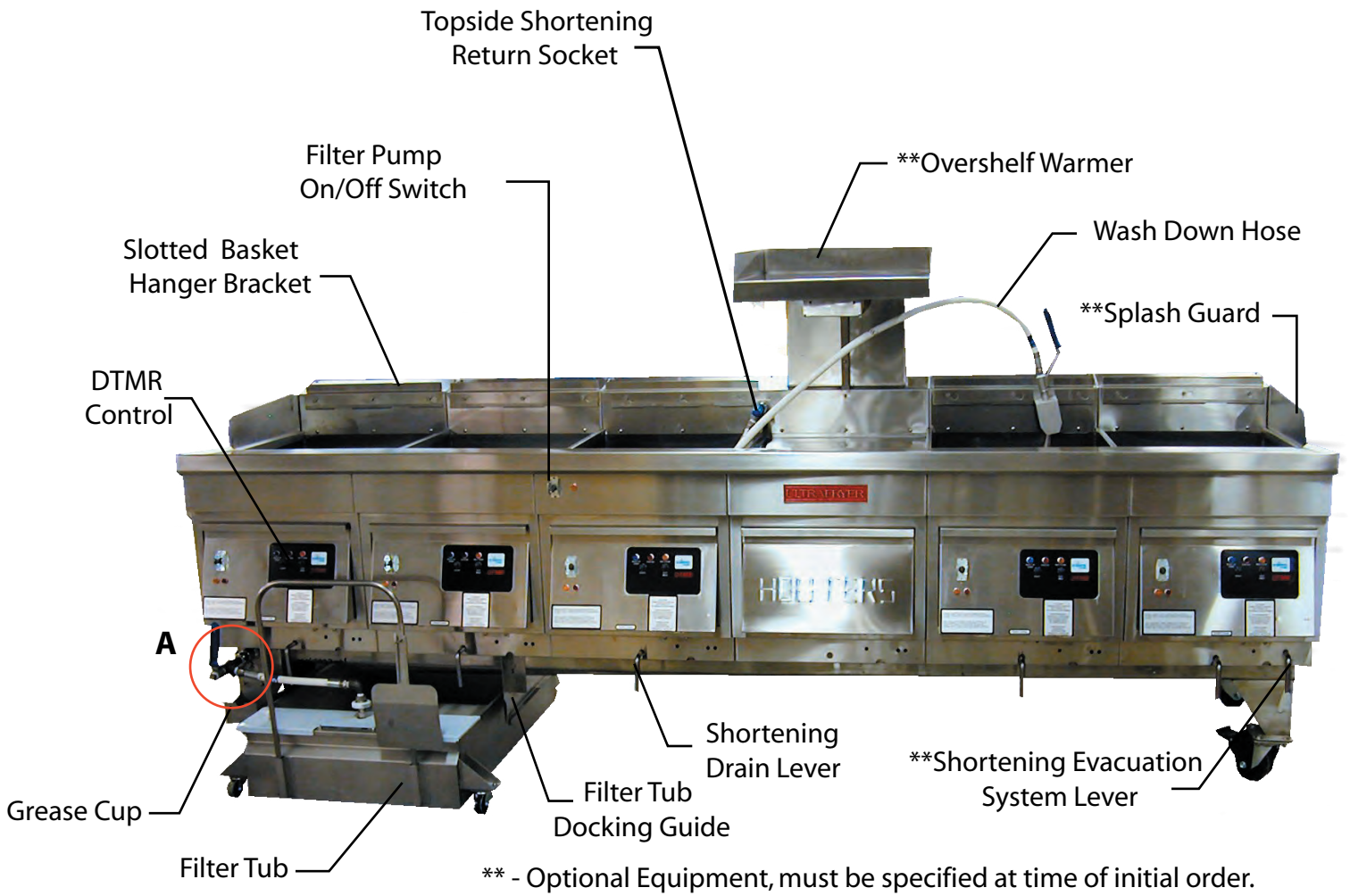

F. OPERATING CONTROLS

The “basic” PAR-3-18 gas fryer is equipped with an Electronic Thermostat and Default-to-Manual-Restart (DTMR) control; However customers may request the fryer be equipped with an “optional” Ultrastat Cooking Computer, such as an Ultrastat 11, 21 or 25 Cooking Computer. When applicable, operating instructions for the Ultrastat Cooking Computer will be provided with the fryer. Operating controls on the Model PAR-3-18-TL gas fryer consist of: Fryer On/Off switch, **AMBER** Power Indicator Lamp and **RED** Burner Indicator Lamp which are located on the Control Access Door, and the Pump On/Off Switch and **AMBER** Pump ON Indicator Lamp located above the Control Access Door. The Drain levers are located beneath the access door and other controls, and gas valves are located behind the hinged access doors. The optional Shortening Evacuation System Lever is located on the last vat outboard of that vat’s drain lever. These controls were identified in the illustrations shown on the previous page.

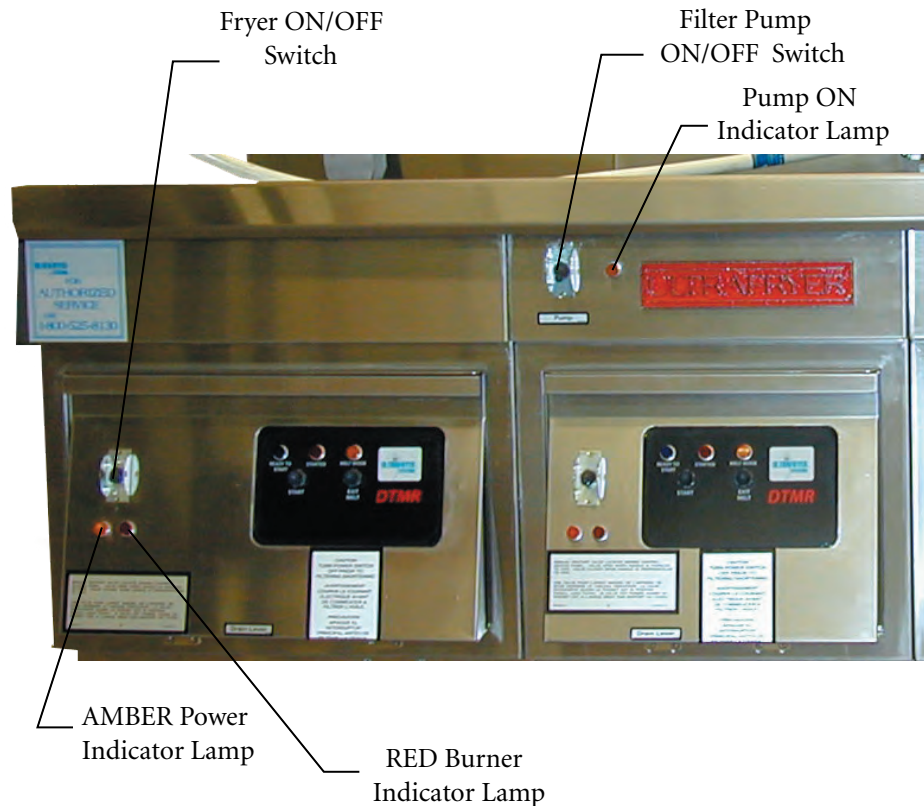

Note: Filter pump switch location determined by the # of fryer vats. Location in illustration is example only.

G. RATING PLATE

Information on this plate includes the model and serial number; BTU/HR input rating of the burners; gas manifold pressure in inches W.C. ; minimum inlet gas required, orifice size; and type of gas. This data is essential for proper identification when communicating with ULTRAFRYER SYSTEMS or requesting special parts or information. The rating plate is located on the inside of the Controller Access door.

THE FRYER MUST BE CONNECTED ONLY TO THE TYPE OF GAS IDENTIFIED ON THIS RATING PLATE!

H. INLET GAS LINE SIZING

The Table below is used to calculate the size (diameter) of the inlet gas line from the building regulator to the fryer manifold.

INLET GAS LINE REQUIREMENTS									
PIPE LENGTH	PIPE DIAMETERS (inches & (mm equivalents)) Maximum Allowable Flow (Shown in ft ³ /hr (M ³ /hr))								
	Feet (Meters)	½" (13mm)	¾" (19mm)	1" (25mm)	1¼" (32mm)	1½" (38mm)	2" (51mm)	2½" (64mm)	3" (76mm)
15 (4.6)	62 (1.7)	170 (4.7)	350 (9.8)	620 (17.4)	960 (26.9)	2,000 (56.0)	3,500 (98.0)	5,400 (151.2)	11,200 (313.6)
30 (9.1)	43 (1.2)	120 (3.4)	245 (6.9)	430 (12.0)	680 (19.0)	1,400 (39.2)	2,450 (68.6)	3,800 (106.4)	7,900 (221.2)
45 (13.7)	35 (1.0)	98 (2.7)	200 (5.6)	355 (9.9)	530 (14.8)	1,150 (32.2)	2,000 (56.0)	3,200 (89.6)	7,900 (182.0)
60 (18.3)	30 (0.8)	84 (2.4)	175 (4.9)	310 (8.7)	480 (13.4)	1,000 (28.0)	1,760 (49.3)	2,700 (75.6)	5,600 (156.8)
75 (22.9)	27 (0.8)	76 (2.1)	155 (4.3)	275 (7.7)	430 (12.0)	890 (24.9)	1,560 (43.7)	2,450 (68.6)	5,000 (140.0)
90 (27.4)	25 (0.7)	70 (2.0)	145 (4.1)	250 (7.0)	395 (11.1)	810 (22.7)	1,430 (40.0)	2,260 (63.3)	4,550 (127.4)
105 (32.0)	23 (0.6)	64 (1.8)	132 (3.7)	232 (6.5)	370 (10.4)	750 (21.0)	1,300 (36.4)	2,100 (58.8)	4,200 (117.6)
120 (36.6)	21 (0.6)	60 (1.7)	125 (3.5)	215 (6.0)	340 (9.5)	700 (19.6)	1,200 (33.6)	1,950 (54.6)	4,000 (112.0)
150 (45.7)	19 (0.5)	54 (1.5)	110 (3.1)	195 (5.5)	310 (8.7)	630 (17.6)	1,080 (30.2)	1,750 (49.0)	3,550 (99.4)
180 (54.9)	17 (0.5)	49 (1.4)	100 (2.8)	175 (4.9)	280 (7.8)	570 (16.0)	960 (26.9)	1,600 (44.8)	3,200 (89.6)
210 (64.0)	16 (0.4)	44 (1.2)	94 (2.6)	165 (4.6)	260 (7.3)	530 (14.8)	890 (24.9)	1,450 (40.6)	3,000 (84.0)
240 (73.2)	15 (0.4)	43 (1.2)	88 (2.5)	155 (4.3)	240 (6.7)	500 (14.0)	840 (23.5)	1,350 (37.8)	2,800 (78.4)
270 (82.3)	14 (0.4)	40 (1.1)	83 (2.3)	145 (4.1)	230 (6.4)	470 (13.2)	780 (21.8)	1,300 (36.4)	2,650 (74.2)
300 (91.4)	14 (0.4)	38 (1.1)	79 (2.2)	138 (3.9)	215 (6.0)	440 (12.3)	750 (21.0)	1,250 (35.0)	2,500 (70.0)
450 (137.2)	11 (0.3)	31 (0.9)	64 (1.8)	112 (3.1)	176 (4.9)	360 (10.1)	630 (17.6)	1,000 (28.0)	2,050 (57.4)
600 (182.9)	10 (0.3)	27 (0.8)	56 (1.6)	97 (2.7)	152 (4.3)	315 (8.8)	530 (14.8)	860 (24.1)	1,750 (49.0)

NOTE: 1) FT³/HR (M³/HR) values may vary due to heating value and specific gravity of gas supplied by local companies.
 2) To determine the inlet gas line diameter for the distance between the fryer and main gas regulator, locate the FT³/HR (M³/HR) of gas required for the fryer and pipe length and read the pipe diameter on the top row. For example: a bank of fryers containing five (5) Par-3-18 Fryers operating on Natural gas requires 580 FT³/HR (15.5 M³/HR) - ((5 x 116 (x))+5 x 3.1 (x)). If the fryer bank is located 60 ft (18.3 M) from the building gas regulator, a 2"(51mm) diameter gas line **MUST** be installed between the manifold and regulator.

I. INLET GAS REQUIREMENTS

INLET GAS REQUIREMENTS MODEL PAR-3-18-TL GAS FRYERS								
VAT SIZE IN MM		GAS VALVE PRESSURE (WC) IN MM		ORIFICE HOLE SIZE	RATING BTU/HR MJ/HR		INLET GAS FLOW AT STP FT ³ /HR M ³ /HR	
18" (457)	Butane	10.0	(254)	#36	110,000	(116)	34	(1.0)
	Natural	4.0	(102)	#10	110,000	(116)	116	(3.1)
	Propane	10.0	(254)	#32	110,000	(116)	44	(1.2)

The Flexible Gas Line used to connect the gas manifold to the building gas supply line must be rated for the BTU/Hr (MJ/Hr) designated for the Fryer. For example: the BTU/Hr (MJ/Hr) rating for a bank of fryers containing five (5) Par-3-18-TL fryers is rated at 550,000 BTU/Hr (580 MJ/Hr) ((5 x 110,000) + (5 x 116)). Flexible gas lines and their ratings stocked by Ultrafryer Systems are listed below:

FLEXIBLE GAS LINES STOCKED BY ULTRAFRYER SYSTEMS			
NUMBER	DESCRIPTION	RATING BTU/HR (MJ/HR)	
24322	¾" (19mm) Diameter Flexible Gas Line (w/quick connect couplings) 48" (1219mm) long. Connect-It SSGC75-48-UCQ	225,000	(238)
24323	1" (25mm) Diameter Flexible Gas Line (w/quick connect couplings) 48" (1219mm) long. Connect-It SSGC100-48-UCQ	435,000	(459)
24456	1¼" (32mm) Diameter Flexible Gas Line (w/quick connect couplings) 48" (1219mm) long. Connect-It SSGC125-48-UCQ	875,000	(924)

PRE-INSTALLATION

A. GENERAL

Safe and satisfactory operation of a Model Par-3-18-TL gas fryer depends on its proper installation. Installation must conform to local codes or, in the absence of local codes, with the current National Fuel Gas Code ANSI Z223.1 (latest edition). In Canada, gas installation shall be in accordance with the current CAN/CGA B 149.1 and .2 installation codes and/or local codes. Each Model Par-3-18-TL fryer should be installed as follows:

1. Placed beneath a properly designed exhaust hood
2. Installed by a licensed plumber.
3. Connected to the type gas for which the unit was fabricated as shown on the rating plate.
4. Connected to the proper size pressure regulator installed in the gas supply line and adjusted to the proper manifold pressure.
5. Connected to the main gas supply line with the proper size supply line.
6. Restrained by use of a restraining device to avoid splashing of hot liquid and to assure tension cannot be placed on the flexible gas line or fittings. **CLEARANCES:** The appliance must be kept free and clear of all combustibles. The minimum clearance from combustible and non-combustible construction is 6" (152 mm) from the sides, and 6" (152 mm) from rear. The fryer may be installed on combustible floors.

NOTE: Adequate clearances must be provided for servicing and proper operation.

B. STANDARDS

Installation must be planned in accordance with all applicable state and local codes, taking into account the following standards:

1. The fryer and its individual shut-off valve must be disconnected from the gas supply piping system during any pressure testing of that system at pressures in excess of ½ psig (3.45kPa). In Canada, gas installation shall be in accordance with the current CAN/CGA B 149.1 and .2 installation codes and/or local codes.
2. The fryer must be isolated from the gas supply piping system by closing its individual manual shut-off valve during any pressure testing of the gas supply piping system at pressures equal to or less than ½ psig (3.45kPa).
3. When installed the fryer must be electrically grounded in accordance with local codes, or in the absence of local codes, in accordance with the current National Electrical code ANSI/NFPA 70 (latest edition). In Canada electrical installation must be in accordance with the current CSA C22.1 Canadian Electrical Code and/or local codes.
4. Other applicable nationally recognized installation standards such as:
 - a. National Fuel Gas Code ANSI Z223.1 (latest edition)
American Gas Association
1515 Wilson Blvd.
Arlington, VA22209
 - b. NFPA Standards #54, #94 and #221 (latest edition)
National Fire Protection Association
470 Atlantic Avenue
Boston, MA 02110
 - c. ANSI Z21.69/CAN/CGA-6.16 AND Z21.41/CAN1 6.9
5. Exhaust vent hood, when installed must conform to the current NFPA 54-1 and Canadian CAN/CGA-1.11 (latest edition)

NOTE: Local building codes will usually not permit a fryer with its open tank of hot oil to be installed immediately next to an open flame of any type, whether a broiler or an open burner or range. Check local codes before beginning installation.

C. AIR SUPPLY AND VENTILATION

The area around the appliance must be kept clear of any combustible or flammable products and avoid any obstruction to the flow of ventilation air as well as for ease of maintenance and service. **NOTHING** is to be stored in the interior of the fryer's cabinet except the filter tub assembly.

1. A means must be provided for any commercial, heavy duty-cooking appliance to exhaust combustion wastes outside of the building. It is essential that a fryer be set under a powered exhaust vent hood or that an exhaust fan be provided in the wall above the unit, as exhaust temperatures are in the vicinity of 400°F (204°C).

NOTE: Strong exhaust fans in a hood or in the overall air conditioning system can produce slight air drafts in the room, which can interfere with burner performance and be hard to diagnose. Air movement should be checked during installation and if burner problems persist, make-up air openings or baffles may have to be provided in the room.

2. Exhaust temperature, in addition to the open tank of hot oil, make the storage of anything on shelving over or behind the fryer unsafe.
3. Filters and drip troughs should be part of any industrial hood, but consult local codes before constructing and installing any hood.
4. Provisions must be made for an adequate supply of fresh air and adequate clearance must be maintained for air openings into the combustion chamber.

RECEIVING & INSTALLING

A. UNPACKING

Check that the container is upright. Use an outward prying motion – **DO NOT USE A HAMMER** - to remove the carton. Check the fryer for visible damage; if such damage has occurred do not refuse shipment, but contact the carrier and file the appropriate freight claims.

B. INSTALLING

If sufficient space is available, roll the assembled fryer into the building, to its operating location and proceed to the **LEVELING** Section. In the event the entrance doors are too narrow to roll the assembled fryer into the building; dis-assemble and reassemble the fryer as follows:

WARNING: IMPROPER INSTALLATION, ADJUSTMENT, ALTERATION, SERVICE OR MAINTENANCE CAN CAUSE PROPERTY DAMAGE, INJURY OR DEATH. READ THE INSTALLATION, OPERATING AND MAINTENANCE INSTRUCTIONS THOROUGHLY BEFORE INSTALLING OR SERVICING THIS EQUIPMENT.

Note: As there are various configuration options, the following procedures are intended as a general guide to aid in the disassembly and reassembly of the Fryer for installation.

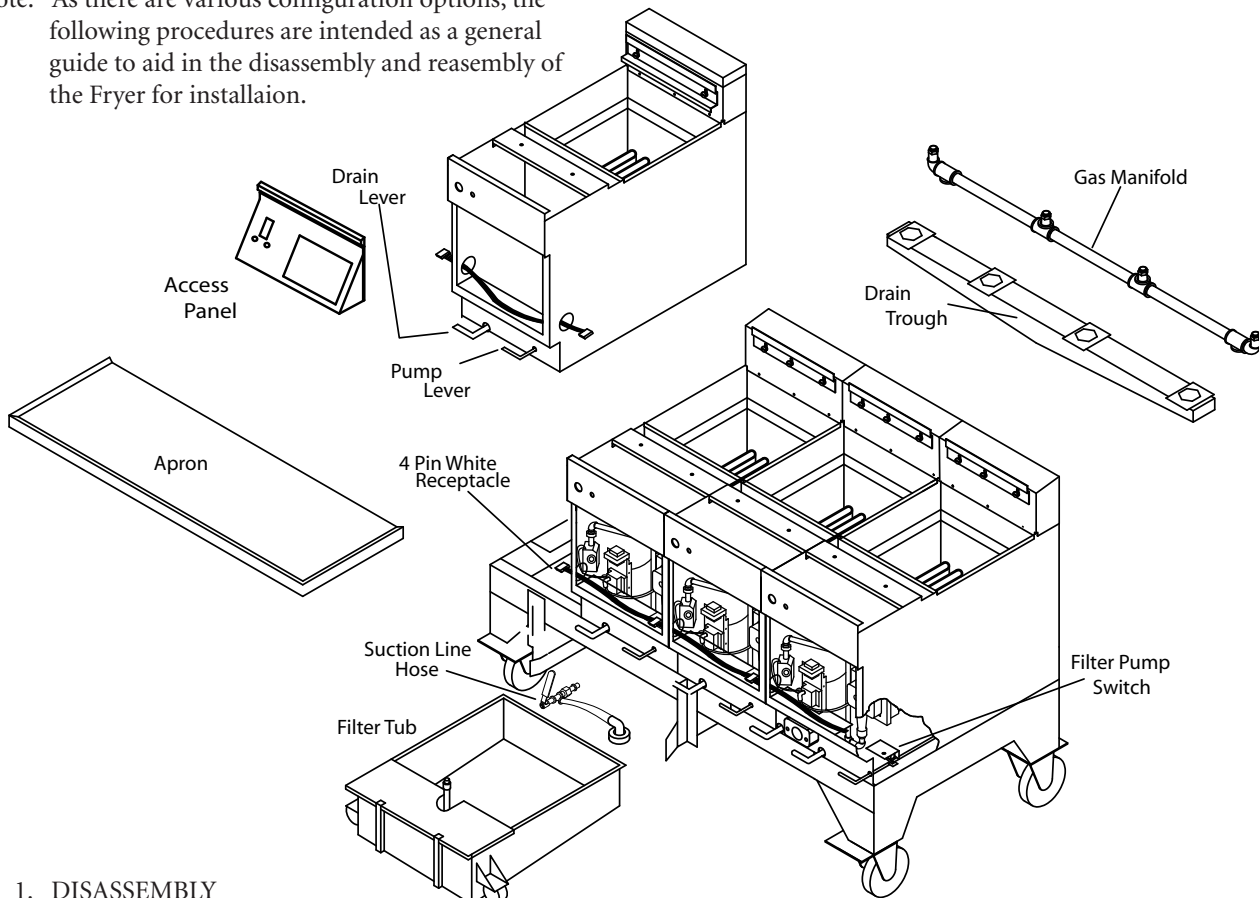

1. DISASSEMBLY

- a. Perform the following steps facing the **FRONT** of the fryer:
 - 1) Number each vat cabinet from **LEFT TO RIGHT** and place these numbers on the front and rear panel of each cabinet.
 - 2) Lower the Temperature Control access panel from each vat cabinet.
 - 3) **CAREFULLY** remove the **APRON** from the fryer bank by removing the two (2) $\frac{1}{4}$ - 20 wing nuts, $\frac{1}{4}$ " (6mm) split washers, and $\frac{1}{4}$ " (6mm) flat washers from each $\frac{1}{4}$ - 20 weld stud beneath each cabinet hat section.

NOTE: It may be necessary to cut the **SILICONE SEAL** between the apron and vat cabinets to separate the apron. **DO NOT DAMAGE THE GASKET.**

- 4) Remove the **JOINER STRIP** located between each set of vats; then cut the **SILICONE SEAL** between the vats.
- 5) **CAREFULLY** separate the **SHORTENING DRAIN TROUGH** from each 2" (51mm) ball valve plate by removing the four (4) $\frac{1}{4}$ - 20 hex head bolts and nuts; then remove the drain trough from the fryer.
- 6) **CAREFULLY** disconnect the **4 PIN WHITE** connector from its mating receptacle located on the **LOWER** right hand end of each vat; then remove the **BLACK** wiring harness protector from the 2" (51mm) opening in each vat.

- 7) **CAREFULLY** disconnect the **ELECTRICAL OUTLET BOX BLACK** and **WHITE** electrical wires connected to wires by **WIRE NUTS** located on the **LEFT HAND** side of the “extreme” **RIGHT HAND** vat.
- 8) Remove the 10-24 truss head screw and nut on the right hand side of each vat used to secure adjoining vats and remove the 10-24 truss head screw and nut that secures the “extreme” left hand vat cabinet to the base frame.

b. Perform these steps facing the **REAR** of the fryer:

- 1) Remove the **REAR** panel from each vat by removing the four (4) pan head self-tapping screws.
- 2) Remove the two (2) 10-24 truss head screws and nuts on the right hand side of each vat used to secure adjoining vats.
- 3) **CAREFULLY** remove the two (2) philips head self-tapping screws along the **BOTTOM** flange of each cabinet.
- 4) **CAREFULLY** loosen and separate the flexible gas line from the gas manifold flare fitting on each vat, remove the ¼ - 20 hex head bolts and nuts from each manifold “**L**” **BRACKET**; then set the **GAS MANIFOLD** aside.
- 5) **CAREFULLY** disconnect the **SHORTENING LINE RED** and **WHITE** heater tape electrical wires terminated in a **3 PIN WHITE** connector from its mating receptacle located on the left hand side of the “extreme” **LEFT HAND** vat.

NOTE: BLACK and WHITE CABLETYES may have to be removed to separate connectors.

- 6) **CAREFULLY** disconnect the **FILTER PUMP MOTOR RED, GREEN** and **WHITE** electrical wires terminated in a **4 PIN WHITE** connector from its mating receptacle located on the left hand side of the “extreme” **LEFT HAND** vat.
- 7) **CAREFULLY** disconnect the **POWER LINE BLACK** and **WHITE** electrical wires terminated in a **4 PIN WHITE** connector from its mating receptacle located on the left hand side of the “extreme” **LEFT HAND** vat.
- 8) **SECURE** the **SHORTENING LINE** to the base frame on the **LEFT HAND** end of the fryer bank; then **CAREFULLY** loosen and separate the shortening line union attached to each ¾” (19mm) ball valve.
- 9) **CAREFULLY** remove each cabinet from the base frame, carry each cabinet into the building; then place the base frame into position in the kitchen.
- 10) **PRIOR** to re-assembling the fryer bank:
 - a. Remove **DRIED** silicone used to seal the apron to vats, opening between each set of vats, front and rear of each cabinet, lower edge of the two (2) end vats, and perimeter of the base frame.
 - b. **THOROUGHLY** clean the **TEFLON TAPE** from all **GAS** and **SHORTENING** fittings and pipes; then wrap all male pipes and fittings with new teflon tape.

2. REASSEMBLY

- a. Place each vat cabinet in numerical order in **FRONT** of the base frame from **LEFT** to **RIGHT**.
- b. Install each vat cabinet on the base frame as follows:
 - 1) Place a bead of silicone around the perimeter of the base frame for the **FIRST** vat cabinet.
 - 2) **CAREFULLY** place **VAT CABINET #1** in position on the base frame; then secure the cabinet to the base frame by installing a 10-24 truss head screw and nut on the left hand flange to the base frame then install two (2) philips head self-tapping screws in the two holes on the **REAR** bottom flange of the cabinet.
 - 3) Repeat the above procedures to install remaining vat cabinets on the base frame.
- c. When all vat cabinets are installed on the base frame, secure the cabinets as follows:
 - 1) Place a bead of silicone along the **FRONT, TOP** and **REAR** space between vat cabinets #1 and #2.
 - 2) Install a 10-24 truss head screw and nut in the ¼” (6mm) holes on the **FRONT** right hand side of vat cabinet #1 and left hand side of vat cabinet #2.
 - 3) Install two (2) 10-24 truss head screws and nuts in the two (2) 13/64” (5mm) holes on the **REAR** left hand side of vat cabinet #1 used to secure it to cabinet #2.
 - 4) Repeat the above procedures to secure remaining vat cabinets to adjoining vat cabinets.

d. Perform these steps facing the **REAR** of the fryer:

- 1) **CAREFULLY** connect each shortening line union **HAND TIGHT**, remove the device used to secure the **SHORTENING LINE** to the **LEFT** end of the base frame; then **SECURELY** tighten each shortening line union.
- 2) Place the **GAS MANIFOLD** in position, secure each manifold **“L” BRACKET** to the frame using the ¼ -20 hex head bolts and nuts removed earlier; then **SECURELY** connect each manual gas valve flexible gas line to the male flare fitting on the manifold.
- 3) **SECURELY** connect the **SHORTENING LINE RED** and **WHITE** heater tape electrical wires terminated in a **3 PIN WHITE** connector to its mating receptacle on the left-hand side of the “extreme” **LEFT HAND** vat. Install a small cabletye on the connection to assure these connectors cannot be separated.
- 4) **SECURELY** connect the **FILTER PUMP MOTOR RED, GREEN** and **WHITE** electrical wires terminated in a **4 PIN WHITE** connector to its mating receptacle located on the left-hand side of the “extreme” **LEFT HAND** vat.
- 5) **SECURELY** connect the **POWER LINE BLACK** and **WHITE** electrical wires terminated in a **4 PIN WHITE** connector to its mating receptacle located on the left hand side of the “extreme” **LEFT HAND** vat.
- 6) Install a large cabletye on the cable harness on the “extreme” **LEFT** and **RIGHT** vats; then replace the **REAR PANEL** on each vat cabinet using eight (8) pan head self-tapping screws in each cabinet panel and fan cover.

e. Perform these steps facing the **FRONT** of the fryer:

- 1) Install the **BLACK** wiring harness protector in the 2" (51mm) opening of each vat; then **SECURELY** connect the **4 PIN WHITE** wiring harness connector to its mating receptacle on each vat.
- 2) **CAREFULLY** connect the **ELECTRICAL OUTLET** box **BLACK** and **WHITE** wires on the “extreme” right hand vat to the **POWER** line **BLACK** and **WHITE** wires using the wire nuts previously removed.
- 3) **CAREFULLY** position the drain trough beneath the fryer; then **SECURE** the drain trough to each 2” (5mm) ball valve plate using four (4) ¼ - 20 hex head bolts and nuts previously removed.
- 4) Remove any dried silicone from each **JOINER STRIP**, place a bead of silicone in each strip; then place the joiner strip over the edge of all adjoining fryer vats.
- 5) **CAREFULLY** replace the **APRON** as follows:

It is advisable to use a clamping method (vice grips, etc) at each vat location when installing the apron retaining hardware.

NOTE: CARE SHOULD BE TAKEN TO AVOID DAMAGING THE UPPER APRON SURFACE WHEN USING CLAMPS.

- a) Place a bead of silicone (supplied) along the **FRONT** edge of each vat cabinet and fill the **REAR** corners of the apron with silicone so it will be flush with the top of the apron.
- b) **CAREFULLY** position the **APRON** on the fryer bank ensuring the **BOTTOM** of the **RED** apron gasket is resting on the front top edge of each vat cabinet as illustrated in Figure 1 on the following page.
- c) **LOOSELY** install one(1) ¼" flat washer, ¼" lock washer and ¼" wing nut on **ALL** apron retaining studs at each vat location prior to tightening.

NOTE: UFS DOES NOT RECOMMEND OR WARRANTY THE USE OF SUBSTITUTED HARDWARE (IE, LOCK NUT, NYLOC) IN LIEU OF THE SUPPLIED WING NUTS.

- d) Once **ALL** wing nuts are installed, **INCREMENTALLY** tighten each wing nut until **SNUG** (finger tight) beginning with the center vat and working outward.

NOTE: DO NOT USE WING NUTS TO TIGHTEN THE APRON AGAINST THE SEAL, DOING SO CAN CAUSE WELD STUD FAILURE AND POSSIBLE DAMAGE TO APRON SURFACE.

- e) Place a bead of silicone along the interior seam of the apron and front panel of each vat, as well as, each vat corner and apron seam as illustrated in Figure 2 on the following page.
- f) Replace the Temperature Control Access Panel.

Apron Seal

FIGURE 1



CAUTION: FAILURE TO SEAL THESE AREAS WILL PERMIT HOT SHORTENING TO SPLASH INTO THE SPACE ALLOWING OIL TO SEEP INTO THE BURNER AREA.

FIGURE 2

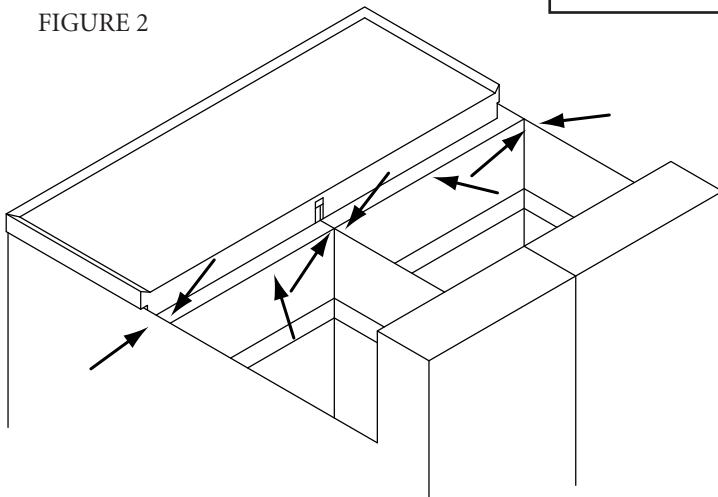

C. LEVELING

1. Roll the fryer to its operating location and check to be sure it is level at this location. If not, loosen the casters and insert the appropriate number of shim plates between leg and caster plates then retighten the caster bolts.
2. If the floor is smooth and level, adjust to the high corner and measure with a spirit level. If the floor is uneven or has a decided slope, level the unit with metal shims.

NOTE: A caster may not return exactly to the same position after being moved, which may require re-leveling after each move.

3. Connect the gas manifold to the building gas supply line by means of an APPROVED flexible gas line as shown in the figure below.

NOTE: CONNECT-IT inc. 3/4" (19mm), 1" (25mm) and 1 1/4" (32mm) flexible gas hose 4 feet long (1219mm) with a quick disconnect coupling on one end is available from Ultrafryer Systems under PN 24322 (3/4" (19mm) hose), PN 24323 (1" (25mm) hose) and PN 24456 (1 1/4" (32mm) hose). These hoses are equipped with a fusible link, which melts at 361°F (183°C) that will **SHUT OFF** the gas supply when it melts. A restraining device 44" (1119mm) long is also available under PN 24324.

CAUTION: THE BUILDING GAS SUPPLY LINE MUST BE SIZED TO PROVIDE THE VOLUME OF GAS REQUIRED FOR PROPER OPERATION AS EXPLAINED IN THE GENERAL INFORMATION SECTION OF THIS MANUAL.

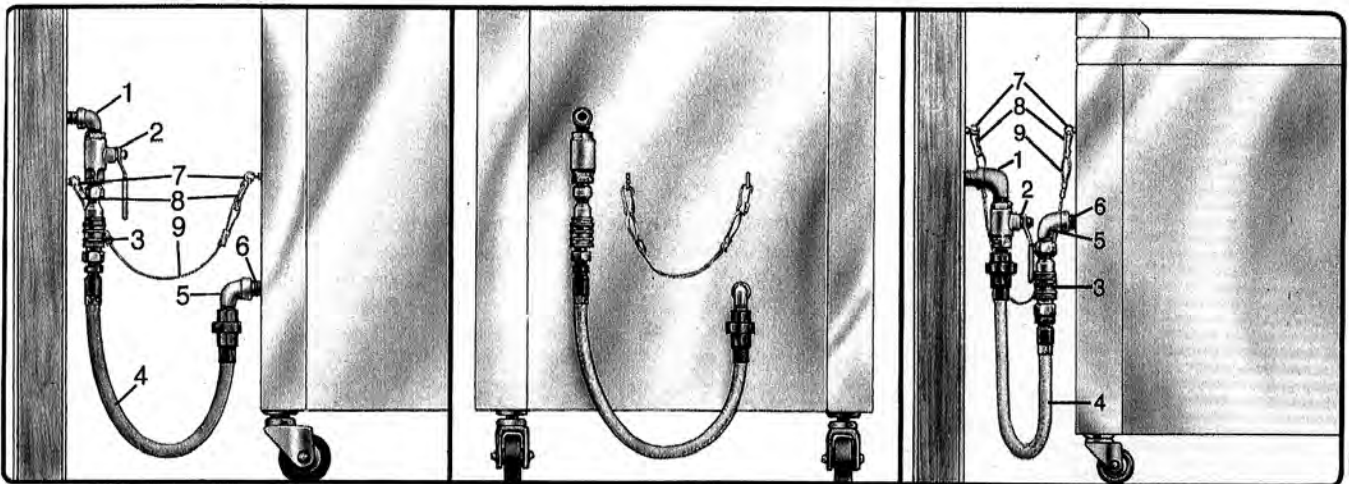

WARNING: THE RESTRAINT DEVICE (ITEM 9) MUST BE INSTALLED TO ASSURE TENSION CANNOT BE PLACED ON THE GAS OR ELECTRICAL LINES AND FITTINGS.

- | | |
|--------------------------------|------------------------------|
| 1. BUILDING GAS SERVICE LINE | 6. APPLIANCE MANIFOLD/NIPPLE |
| 2. MAIN GAS CUT-OFF VALVE | 7. EYELET FASTENERS |
| 3. CONNECT-IT QUICK-DISCONNECT | 8. SPRING HOOK |
| 4. FLEX-CON CONNECTOR | 9. RESTRAINING CHAIN |
| 5. ELBOW | |

D. GAS CONNECTION

The gas supply (service) line must be the same size or greater than the inlet line of the appliance. **THE GAS SUPPLY LINES MUST BE SIZED TO ACCOMMODATE ALL THE GAS FIRED EQUIPMENT THAT MAY BE CONNECTED TO THAT SUPPLY.** Refer to the Inlet Gas Line Sizing Table and inlet gas requirements in the GENERAL INFORMATION section..

NOTE: Sealant used on all pipe joints must be resistive to butane and propane gas.

1. Manual shut off valve: This supplier-installed valve must be installed in the gas service line ahead of the appliance and in a position where it can be reached quickly in the event of an emergency.
2. Pressure regulator: All commercial cooking equipment must have a pressure regulator on the incoming service line for safe and efficient operation, because service pressure may fluctuate with local demand. External regulators are not required on this fryer, as that function is performed by a combination gas control valve, however if the incoming pressure is in excess of ½ psig, a step-down regulator will be required.
3. Natural gas: Natural gas fryers require 7" (178mm) water column (W.C.) inlet pressure to the fryer's combination gas control valve for proper operation, when all gas units are operating simultaneously. Butane and Propane gas fryers require 14" (356mm) (W.C.) inlet pressure to the fryer's combination gas control valve for proper operation, when all gas units are operating simultaneously. This inlet pressure **MUST** be checked with a nanometer **PRIOR** to placing the fryer in operation.

WARNING: IF THE INLET GAS PRESSURE AT THE FRYER'S COMBINATION GAS CONTROL VALVE EXCEEDS ½ lb/in² (.035 kg/cm²) OR APPROXIMATELY 14" (356 mm) W.C., AN EXTERNAL REGULATOR MAY BE NEEDED TO PREVENT DAMAGE TO THE COMBINATION GAS VALVE AND VOIDING OF THE WARRANTY. FAILURE TO ADDRESS THIS COULD RESULT IN EXPLOSION OR FIRE.

4. Combination gas control valve: The correct combination gas control valve and orifice is installed at the factory for BUTANE, NATURAL and PROPANE units based on each Purchase Order. This valve should be CHECKED /ADJUSTED by qualified service personnel using proper test equipment for the following OUTLET gas pressure PRIOR to start-up of a fryer.
 - a. NATURAL GAS FRYERS 4" (102mm) water column (W.C.)
 - b. BUTANE/PROPANE FRYERS 10" (254mm) water column (W.C.)
5. Rigid connections: Visually check and purge any installer-supplied intake pipe(s) with compressed air to clear dirt particles, threading chips or any other foreign matter before connecting to the service line as these particles may clog the orifice when gas pressure is applied. All connections must be tested with a soapy solution before lighting the fryer. **DO NOT USE AN OPEN FLAME TO CHECK FOR LEAKS!** Putting an open flame beside a new connection is not only dangerous, but will often miss small leaks that a soapy solution would find.

E. FLEXIBLE COUPLINGS, CONNECTORS

The installation is to be made with a connector that:

- (1) Complies with the **Standard for Connectors for Movable Gas Appliances, ANSI Z21.69 (CAN/CGA-6.16)**, and a quick-disconnect device that complies with the **Standard for Quick-Disconnect Devices for Use With Gas Fuel, ANSI Z21.41 (CAN1-6.9)**
- (2) Adequate means must be provided to limit the movement of the appliance without depending on the connector and the quick disconnect device or its associated piping to limit the appliance movement.
- (3) The location(s) where the restraining means may be attached to the appliance shall be specified.
DOMESTIC CONNECTORS ARE NOT SUITABLE!!!

F. FRYER SERVICE

The fryer is equipped with swivel casters. To service the fryer:

1. Turn OFF gas supply at the supply source.
2. Disconnect the flexible gas line quick-disconnect
3. Disconnect restraint means and roll fryer out for rear service access.
4. When the fryer is re-positioned, be sure to reconnect the restraint and level the fryer.

G. ELECTRICAL CONNECTION

The **MAXIMUM** current draw per vat at Initial Start-up or during a Warm-up Cycle will be 3 Amperes at 120 Volts. When running the Filter System simultaneously allow for an additional 3 Amperes. Refer to the wiring diagram attached to the front door of the fryer for internal electrical connections.

H. DEFAULT-TO-MANUAL-RESTART (DTMR) CONTROL

The “basic” gas fryer is equipped with a Default-to-Manual-Restart (DTMR) Control. This control contains a Default-to-Off electrical circuit that **DISABLES** a fryer any time the drain valve is **OPENED**, and a Default-to-Melt electrical circuit which automatically places a fryer in a shortening **MELT MODE** to gradually and **SAFELY** melt shortening each time a fryer is truned **ON** and the **START BUTTON** is drepressed on the **DTMR** control. The Default-to-Manual-Restart Control is intended to avoid “operator errors” that can result is **DRY FIRING** a fryer causing shortening to be scorched, heat exchanger damage and/or a vat fire.

1. DTMR CONTROL PANEL

BLUE READY TO START LAMP

When lit indicates the power On/Off switch is in the ON position, the drain valve is **CLOSED**, and the fryer is ready to operate.

START BUTTON

When this button is momentarily depressed, it places the fryer in operation.

RED STARTED LAMP

When lit indicates the **START BUTTON** has been momentarily depressed and the fryer is operating.

AMBER MELT MODE LAMP

When lit indicates the **MELT CYCLE TIMING MODULE** in the Default-To-Melt circuit is cycling the fryer Heat System **ON** for twelve (12) seconds and **OFF** for 28 seconds to safely heat shortening.

EXIT MELT BUTTON

When this button is momentarily depressed the **MELT CYCLE TIMING MODULE** in the Default-To Melt circuit will switch to the **FULL ON** position allowing the electronic thermostat to heat shortening to its pre-set temperature.

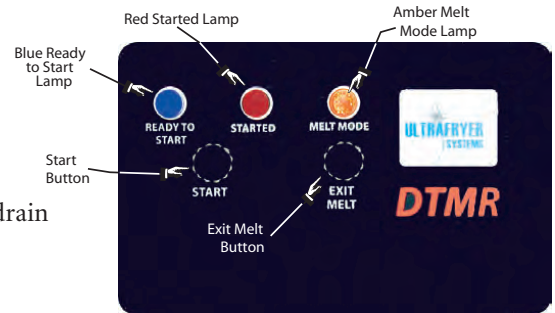

I. OPTIONAL CONTROLS

The fryer may be equipped with an Ultrastat Model 11, 21, or 25 Cooking Computer as described below:

1. ULTRASTAT 11 COOKING COMPUTER

Some fryers are equipped with an Ultrastat 11 Cooking Computer which is connected to the fryer’s electrical system to serve as its thermostat as well as providing heat control, status information and product cook timer. When the computer is in operation it will **DISABLE** the fryer if the drain valve is **OPENED**. Operation of the Ultrastat 11 Cooking Computer is covered in the [Ultrastat 11 Ultrafryer Computer Operation instruction](#) PN 30A053 provided with Fryers equipped with that Cooking Computer.



2. ULTRASTAT 21 COOKING COMPUTER

The Ultrastat 21 Cooking computer is in compliance with the limits for a class B computing device pursuant to Sub-Part J of Part 15 of the FCC Rules. This cooking computer is capable of cooking up to eight (8) different products; each of which can be programmed to be cooked from one (1) to ten (10) different temperature at different times in a cook cycle. In addition, the operator can program the ULTRASTAT 21 computer to cook products under “**FLEX**” or “**STRAIGHT**” timing modes. When programmed for “**FLEX**” time mode the computer will adjust the actual cook time taking into consideration the temperature variation due to load size, initial product temperature, product moisture content, and other factors that affect the cook cycle. Under “**STRAIGHT**” time mode, the product is cooked at a specified tempaure for the length of time programmed without adjusting for these variations. Operation of the ULTRASTAT 21 cooking computer is covered in the [ULTRASTA 21 Gas Fryer Computer Operation Instructions](#) PN 30A009 proided with fryers equipped that computer.



3. ULTRASTAT 25 COOKING COMPUTER

The Ultrastat 25 Cooking Computer is a high performance, micro-processor based electronic controller designed for use in commercial appliance temperature and timing control applications. Utilizing a microcontroller board, membrane switch front panel with a digital LED readout, and display board, the Ultrastat 25 Cooking Computer has been customized for Ultrafryer Systems applications by the addition of up to (10) stage cooking profiles for each of the (8) product keys, exit melt feature, optional temperature setback and filtering prompt, and can be programmed to cook products under “Flex” or “Straight” timing modes. Operation of the Ultrastat 25 Cooking Computer is covered in its Instruction Manual PN 30A051 provided with Fryers Equipped with that computer.

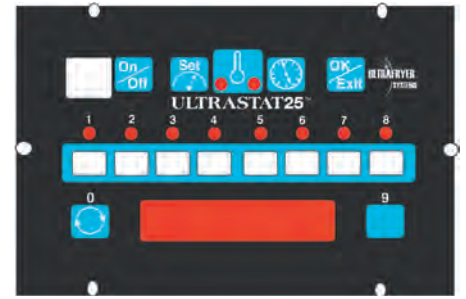

INITIAL START-UP

A. GENERAL

New units are wiped clean at the factory to remove any visible signs of dirt, oil, grease, etcetera, remaining from the manufacturing process. Each fryer vessel should be thoroughly washed with hot soapy water to remove film residues, installation dust or debris; and then wiped dry before being used for food preparation.

B. START-UP

The fryers are tested, adjusted and calibrated prior to being shipped: however adjustments may be necessary on installation to meet local conditions, high or low gas pressure, differences in altitudes, variations in gas characteristics and to correct possible problems caused by rough handling or vibration during shipment. Initial calibration or adjustment is the responsibility of the customer and will not be covered by the Ultrafryer Systems warranty.

NOTE: Calibration and adjustments must be performed by qualified personnel.

C. LIGHTING INSTRUCTIONS

Each fryer is equipped with a spark ignition system and to test this system, perform the following steps, in sequence:

1. Turn the **On/Off SWITCH** to the **OFF** position.
2. Fill the fryer vessel with hot or cold water to the **SHORTENING LEVEL** mark.

CAUTION : IF THE MAIN BURNERS ARE OPERATED WITH THE VESSEL EMPTY, THE HEAT WILL CAUSE THE JOINTS OF THE FRYER VESSEL TO BE PLACED UNDER UNDO STRESS AND MAY CAUSE THE HEAT EXCHANGER VESSEL TO WARP OR BUCKLE, VOIDING WARRANTY.

3. Turn the manual gas valve behind the fryer control access door of the fryer to the **OFF** position and wait **FIVE (5)** minutes for any accumulated gas to disperse.
4. **ENSURE** the **MAIN** gas shut-off is in the **ON** position, **MANUAL VALVE** on the combination **GAS CONTROL VALVE** (located behind the fryer control access door) is in the **ON** position and the Vent Hood **EXHAUST FAN** is **ON**.
5. Turn the manual gas valve to the **ON** position.
6. Turn the Fryer **On/Off** switch **ON**; then place the **DTMR** or **ULTRASTAT** Cooking Computer into the **MELT MODE**.

WARNING!!! DO NOT USE A MATCH OR CANDLE TO LIGHT A FRYER... EVER!

D. SEQUENCE OF IGNITION

When the lighting instruction steps are performed in the sequence listed above, the following will occur:

1. Blower will come **ON** activating the air pressure switch.
2. The air pressure switch will **CLOSE** completing the electrical circuit to the transformer.
3. The transformer will supply 24 volts to the **IGNITOR MODULE** and **GAS CONTROL VALVE**, and the ignitor will **SPARK** lighting the gas in the burner.

WARNING!!! WHEN CHECKING FOR BURNER PERFORMANCE, DO NOT STAND WITH YOUR FACE CLOSE TO THE BURNER.... IT MAY LIGHT WITH A "POP" AND COULD FLASH BACK AND CAUSE FACIAL BURNS.

- NOTES:**
- 1) If the burner flame fails, it will be sensed by the **SPARK IGNITOR**, the Spark Ignitor Module will open the electrical circuit to the **GAS CONTROL VALVE** shutting off gas to the burner.
 - 2) If the blower fails, the air pressure switch will open the electrical circuit to the **TRANSFORMER** removing electrical power from the **SPARK IGNITOR MODULE** and **GAS CONTROL VALVE** shutting off gas to the burner.

E. BURNER OPERATION TEST

Perform above **LIGHTING INSTRUCTIONS** and observe operation of the burners. When satisfied that the burner is operating properly, drain the fryer vessel of water and dry the vessel thoroughly; then fill the fryer vessel with shortening according to the instruction, below.

F. SHORTENING INSTALLATION

1. Install shortening as per the instructions in the SHORTENING DISPOSAL, BOIL-OUT & INSTALLATION Section of this manual.

G. START-UP

1. GENERAL

- a. The Default-to-Manual-Restart (DTMR) Control along with an Electronic Thermostat is connected to a fryer’s electrical system to control operation of the fryer. The DTMR contains a Default-to-Off circuit that will **DISABLE** the fryer anytime the Drain Valve is **OPEN**, and a Default-to-Melt circuit that will automatically place the fryer in a **SHORTENING MELT MODE** to gradually and safely heat shortening each time the fryer’s On/Off Switch is turned **ON**.

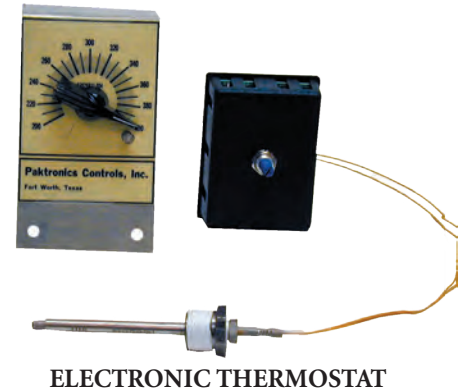

- b. Electronic Thermostat

The Electronic Thermostat has a temperature range from 200°F (93°C) to 400°F (204°C) and will accurately maintain a pre-set shortening cook temperature within ± 2° of the pre-set temperature.

2. START-UP

- a. TO TEST OPERATE an Ultrafryer Gas Fryer equipped with a Default-to-Manual-Restart (DTMR) control:
 - 1) Ensure the fryer’s On/Off Switch is in the **OFF** position.
 - 2) Fill the fryer vat with hot or cold water to the middle of the “E” in the word **LEVEL** of the applicable shortening level mark on the rear of the vat.
 - 3) Turn the **MANUAL** gas valve to the **OFF** position and wait **FIVE (5)** minutes for any accumulated gas to disperse.
 - 4) **ENSURE** the **MAIN** gas shut-off valve is in the **ON** position, and that the Vent Hood **EXHAUST FAN** is **ON**.
 - 5) Turn the **MANUAL GAS VALVE** to the **ON** position.
 - 6) Perform the steps on the following page, in the order listed:

ITEM	ACTION	DTMR CONDITION
1	ENSURE the drain valve is in the CLOSED position and that water is at the proper level; then turn the switch to the ON position.	A. The AMBER power indicator will LIGHT . B. BLUE READY TO START lamp will LIGHT .
CAUTION: PRIOR TO PROCEEDING TO STEP 2 VISUALLY CHECK THAT THE HEAT MECHANISM IS COVERED WITH AT LEAST 2" (51 mm) OF WATER.		
2	Depress, then release the momentary START button	A. RED STARTED lamp and AMBER MELT MODE lamp will light. B. BLUE READY TO START lamp will turn OFF . C. A TIMER in the Default-To-Melt electrical circuit will begin cycling the fryer heat mechanism ON for twelve (12) seconds and OFF for 28 seconds to safely heat the water.
CAUTION: PRIOR TO PROCEEDING TO STEP 3, VISUALLY CHECK THAT THE WATER COMPLETELY COVERS THE HEAT MECHANISM.		
3	When the water is heated depress, then release the momentary EXIT MELT button.	A. AMBER MELT MODE lamp will turn OFF and the RED STARTED lamp will remain lit. B. The TIMER in the Default-To-Melt circuit will switch to the FULL ON position, allowing the Electronic Thermostat to heat the water.
4	When the water begins to boil, turn the switch to the OFF position.	A. The AMBER power lamp will turn OFF .
5	After the water in the vat and metal surfaces of the fryer have COOLED , drain the water into a floor drain.	

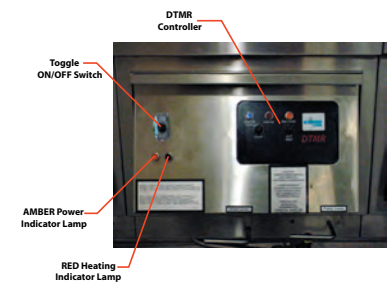
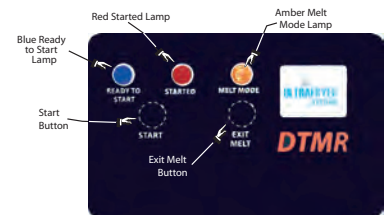

- b. TO TEST OPERATE a Ultrafryer Gas Fryer equipped with an Ultrastat 11 Cooking Computer, use the procedures contained in the “Ultrastat 11 Gas Fryer Computer Operation Instructions”, PN 30A053, provided with the fryer.
- c. TO TEST OPERATE a Ultrafryer Gas Fryer equipped with an Ultrastat 21 Cooking Computer, use the procedures contained in the “Ultrastat 21 Gas Fryer Computer Operation Instructions”, PN 30A009, provided with the fryer.
- d. TO TEST OPERATE a Ultrafryer Gas Fryer equipped with an Ultrastat 25 Cooking Computer, use the procedures contained in the “Ultrastat 25 Gas Fryer Computer Operation Instructions”, PN 30A051, provided with the fryer.

ABBREVIATED OPERATING INSTRUCTIONS

A GENERAL

This fryer is equipped with a shortening filter system which is to be cleaned and operated according to the CLEANING and FRYER OPERATION sections of this manual.

1. SHORTENING

Use a high quality shortening to achieve a consistent quality product as well as a long term savings.

2. SHORTENING TEMPERATURE

Most products should be cooked with a shortening temperature about 350°F (177°C); however, each product should be cooked at the **LOWEST** temperature that produces a high quality product while obtaining maximum usage of the shortening.

3. SALTING

Products should not be salted over the fryer vessel as salt quickly deteriorates the shortening and flavors other products cooked in the same shortening.

4. POWER FAILURES

The fryer cannot be operated during power failures. **DO NOT** attempt to manually operate the fryer.

5. PUMP MOTOR

The filter pump motor is protected by a motor thermal overload switch.

CAUTION: ENSURE THE WASH DOWN HOSE IS NOT CONNECTED TO A FRYER PRIOR TO RESETTING A THERMAL OVERLOAD SWITCH.

B FILTERING SHORTENING

The fryer must be filtered at least twice a day (once after the lunch rush and again after the dinner rush). Place the recommended amount of filter agent in the shortening as prescribed by the chemical supplier and follow instructions for filtering shortening provided in the FRYER OPERATION section of this manual.

C LEVELING SHORTENING

After filtering, the shortening level must be checked and fresh shortening added when necessary.

1. The shortening in the vat should reach to the middle line of the “E” in the word LEVEL of the applicable shortening level mark on the rear wall of the fryer.
2. If shortening is needed, use the filter scraper to cut off a small block of solid shortening.
3. Place the small block of shortening into a fry basket, lower the basket into the shortening; then turn the basket to allow the block to float freely.
4. Repeat the above steps until the shortening in the vat is at the proper level.

D BOILING OUT FRYER

The fryer should be **BOILED OUT** every **7 DAYS** to remove carbon buildup and other encrusted materials. Add the amount of boil out compound to the fryer as prescribed in the cleaning manual provided by the chemical supplier and follow instructions for boiling out a fryer in the FRYER OPERATION section of this manual.

E CLOSING/SHUTDOWN INSTRUCTIONS

1. CLOSING

When closing at night; filter the shortening in the fryer, **THOROUGHLY** drain all filter lines and cover the fryer vessel. Turn the **On/Off** Switch on the fryer **OFF** and turn the Manual Gas Valve **OFF**.

2. SHUTDOWN OR PROLONGED POWER FAILURE

a. Shutdown

Perform the following whenever a fryer is being shutdown for an extended period of time:

- 1) Drain and discard the shortening.
- 2) **THOROUGHLY** clean the fryer vat.
- 3) Turn the On/Off Switch to the **OFF** position, disconnect the 120-volt power cord and turn applicable Circuit Breakers **OFF**.
- 4) Turn the Manual Gas Valve **OFF**.

b. Prolonged power failure: The fryer cannot be operated during power failures. **DO NOT** attempt to bypass safety controls and manually start the fryer.

F CLEANING

Any item of equipment operates better and lasts longer when it is kept clean and properly maintained, and this fryer is no exception. In order for the fryer to provide years of trouble-free service, it must be **CLEANED** and **MAINTAINED** according to the CLEANING section of this manual.

1. DAILY

- a. FILTER shortening in each fryer vat after the **LUNCH** and **DINNER** rush and more often in high volume sale stores.

CAUTION: PRIOR TO CLEANING THE FRYER VAT, REMOVE THE 120 VOLT ELECTRICAL PLUG FROM THE ELECTRICAL RECEPTACLE AND TURN THE MANUAL GAS VAVLE OFF.

- b. **Clean** the fryer surface with a solution of hot water and detergent periodically during operating hours and with stainless steel cleaner at closing. If necessary, use a dampened 3M type **7447 RED** or 3M type **7440** heavy duty **BROWN** Scotchbrite pad to remove encrusted material. **DO NOT** use steel wool, abrasive cloths, cleaners, powders, metal knife, spatula or any other metal object to scrape stainless steel! Scratches on stainless steel are almost impossible to remove!

CAUTION: DO NOT ALLOW ANY CLEANING SOLUTION/WATER TO SPLASH INTO A VESSEL OF HOT COOKING OIL AS IT WILL CONTAMINATE THE OIL AND MAY CAUSE THE OIL TO SPALTTER CAUSING SEVERE BURNS.

- c. **THOROUGHLY** clean the filter machine according to instructions provided in the cleaning section of this manual.

2. WEEKLY

- a. **BOIL OUT** the fryer vat using Boil Out Compound according to procedures in the cleaning manual provided by the chemical supplier
- b. Perform steps F 1 a through F 1 c listed above.

ELECTRONIC THERMOSTAT CALIBRATION

A. GENERAL

If the fryer is equipped with an Ultrastat 11, 21, or 25 Cooking Computer **NO** maintenance is required on the Temperature Sensing Probe. However, if the fryer is equipped with a Default-to-Manual-Restart (DTMR) Control, the Electronic Thermostat may need to be adjusted or calibrated according to the following procedure:

B. ELECTRONIC THERMOSTAT CALIBRATION

The Electronic Thermostat in all fryer configurations are equipped with a Dial and Knob and should be checked and calibrated when necessary as follows:

1. **ENSURE** electrical power and, if applicable, gas to the fryer has been turned **OFF**.
2. **CAREFULLY** drain sufficient shortening from the fryer to **LOWER** the shortening about 4" (102 mm) beneath the Electronic Thermostat sensing probe.
3. After the sensing probe has **COOLED**, loop the Sensing Element of an **ACCURATE** digital test thermometer temperature probe around the sensing element; then connect the probe to the test thermometer.
4. Replace shortening drained in step 2 and **ENSURE** it is level with the shortening level mark on the rear of the vat; then turn the power and, if applicable, gas to the fryer **ON**.
5. Set the **KNOB** of the Electronic Thermostat to the **CENTER** (300) of the dial and periodically **STIR** the shortening in a **COUNTER-CLOCKWISE (CCW)** direction with a long handle skimmer to pull congealed shortening **UPWARD** from the Cold Zone area.
6. When shortening has reached the set temperature and the **RED** indicator lamp on the fryer has turned **OFF**, allow the Electronic Thermostat to cycle **ON** and **OFF** about five (5) times to stabilize the system.
7. After the shortening temperature has stabilized, record the temperature reading of the **TEST THERMOMETER** immediately after the **RED** indicator lamp and the fryer turns **OFF**.
8. **CAREFULLY** loosen the set screw on the Electronic Thermostat **KNOB** without turning the thermostat potentiometer, set the thermostat knob pointer to the temperature recorded by the test thermometer; then tighten the set screw on the thermostat knob taking care not to turn the thermostat's potentiometer.
9. Repeat steps 1 and 2 above, remove the test thermometer temperature probe from the Electronic Thermostat sensing element; then repeat step 4 to return the fryer to normal operation.

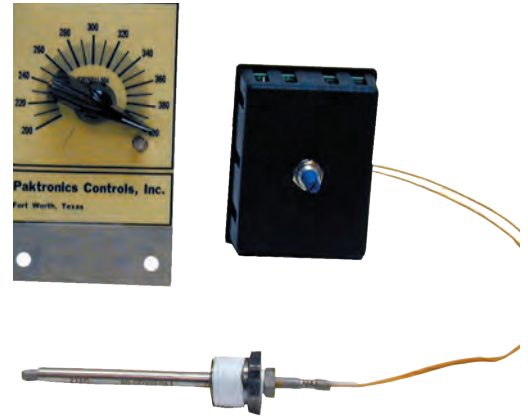

PREVENTIVE MAINTENANCE & TROUBLESHOOTING

A. PREVENTIVE MAINTENANCE

Minimal maintenance is required on the fryer because of its design and the materials used in manufacture. However, some preventive maintenance and inspection must be performed periodically to prevent break downs which could curtail food sales. Any preventive maintenance or inspection should be accomplished with **CAUTION** while the fryer is in operation since **HOT** liquid shortening could cause severe burns. If service or repair is required, all gas and electric power **MUST BE TURNED OFF PRIOR TO** performing that service or repair.

PREVENTIVE MAINTENANCE SCHEDULE	
INSPECTION ITEM	INSPECTION DESCRIPTION
DAILY	
Grease Filters	Clean grease filters in the exhaust hood each evening and allow them to dry overnight.
Filter Tub	Thoroughly clean the filter tub assembly prior to leaving the store at closing
NOTE: ENSURE THE WASH DOWN HOSE IS HUNG IN AN UPRIGHT POSITION (BY ONE END) SO SHORTENING CAN DRAIN INTO A CONTAINER!	
WEEKLY	
Drain Valve & Shortening Return Levers	Determine that all levers are securely attached and that they can be easily opened and closed.
Drain Hoses	Inspect the suction line hose, wash down hose and if applicable the shortening disposal hose for any evidence of deterioration.
Plumbing Heat Tape Insulation	Ensure that the insulation and electric heat tape that are wrapped around the plumbing directly behind the drain trough has not been damaged.
Temperature Sensing Probes	During Boil-Out of the fryer, inspect the temperature and high limit sensing probes for any visual damage.

B. TROUBLESHOOTING

I. GENERAL

The problems and possible solutions listed in the troubleshooting chart below are typical problems that are frequently encountered. **ONLY** qualified repairmen are to use the troubleshooting chart to repair this fryer. In the event a main burner malfunction occurs, perform the following checks **PRIOR** to contacting a repairman:

- a. Ensure Gas Valves are in their proper position.
- b. Check that the fryer electrical plug is connected to an electrical receptacle.
- c. Ensure the applicable Circuit Breaker is in the **ON** position and that the fryer On/Off switch is in the **ON** position.
- d. Ensure the applicable fryer control has been placed in the **FULL ON** mode.
- e. Ensure the gas supply line quick-disconnect coupling is **SEATED** on the gas manifold fitting.
- f. Determine that the blower is operating.

C. TROUBLESHOOTING CHART

Should a problem occur that cannot be corrected after performing the above CHECKS, contact an authorized repairman and/or Ultrafryer Systems Customer Service 1-800-525-8130 and provide the information acquired while performing these checks.

CAUTION: ENSURE REPAIRMEN ARE ADVISED THAT FRYER RESTRAINTS MUST BE DISCONNECTED/CONNECTED. IF A FRYER IS TO BE MOVED DURING MAINTENANCE OR REPAIR, AND THAT ELECTRICAL POWER AND GAS MUST BE TURNED OFF PRIOR TO PERFORMING ANY MAINTENANCE OR REPAIR.

TROUBLESHOOTING CHART		
ITEM	PROBLEMS	POSSIBLE SOLUTIONS
1	Main burner will not ignite. Blower is operating; but gas is not present at the burner.	<p>A. Check the Blower air pressure Switch by temporarily disconnecting the two (2) ORANGE air switch wires and connecting them together. If the IGNITOR sparks when these wires are conected, the air pressure switch is defective and it will have to be replaced.</p> <p>B. Check the following components and replace if found to be defective: Gas Control Valve Hi-Limit Switch Transformer</p>
2	Electrical power is present at the fryer, but the Blower is not operating.	<p>A. Blower may have over-heated and shut off on thermal over-load. If this situation did occur, it will correct itself when the motor cools (10-20 minutes). If this overheating problem persists, replace the blower.</p>
3	Excessive time is required to raise the shortening to cooking temperature. Temperature recovery is slow and main burner flames are small and appear to be lethargic.	<p>A. Ensure that the MANUAL GAS VALVE is completely open.</p> <p>B. Check for an obstruction in the gas line.</p> <p>C. Check for an obstruction in the flue pipe.</p> <p>D. Check that the ORFICE PLUG has the correct drill size opening as indicated on the operational requirements chart.</p> <p>E. Check for damaged BLOWER fins.</p> <p>F. Use a standard water-type U-gauge Manometoer to check the pressure at the gas control valve pressure tap. Proper gas pressure is indicated on the operational requirements chart.</p> <p>NOTE: If necessary remove the Pressure Regulator Adjustment Cover and adjust this control to the proper pressure. (Turn adjusting screw CLOCKWISE to increase gas pressure to the burner and COUNTER CLOCKWISE to decrease gas pressure. Replace adjustment cover.)</p>
4	Shortening temperature is too high and breaks down quickly.	<p>A. Check the gas pressure as described above.</p> <p>B. Check calibration of the Electronic Thermostat with an ACCURATE digital thermometer.</p>
5	The filter pump motor fails to operate when the Vat Shortening Return / Topside Shortening Lever is placed in the OPEN position.	<p>A. Insure the filter pump micro-switch is good, then check the manual reset button on the filter pump motor.</p> <p>B. If the filter pump motor fails to operate after the reset button has been depressed, repair or replace the motor.</p>
6	Decreased shortening flow rate while filtering.	<p>A. Check for excessive sediment on the filter screen, standpipe suction fitting or in the filter tub.</p>
7	Pump/Motor operates but does not pump shoretening.	<p>A. Check for congealed shortening in the shortening system.</p> <p>B. Check for loose Standpipe/Suction Line Coupler connection.</p>
8	Pump/Motor hums but will not pump shortening	<p>A. Check for congealed shortening in the pump or in shortening plumbing.</p>

CLEANING

A. GENERAL

Any item of equipment operates better and lasts longer when it is kept cleaned and properly maintained, and the **FRYER** and **FILTER TUB ASSEMBLY** are no exception. Clean the **FILTER SCREEN** after Filtering Shortening and at Closing; and **THOROUGHLY** clean the **FILTER TUB ASSEMBLY** each **DAY** and **WEEK** as described below.



Wash Down Hose

B. DAILY

1. Clean the Filter Machine and Filter Assembly after **FILTERING** and **AT CLOSING** as follows:
 - a. Disassemble the Filter Machine by removing the following items in the order listed; (1) **FILTER TUB HANDLE**, (2) **COVER**, (3) **WASH DOWN HOSE**, (4) **SUCTION LINE HOSE**, and (5) **FILTER ASSEMBLY**.
 - b. Clean the Suction Line Hose and Wash Down Hose with sanitizer solution; then hang these hoses in an upright position so any shortening can drain into a container.
 - c. Raise the Filter Assembly above the Filter Tub and let any sediment or shortening drain into the tub; then **THOROUGHLY** clean the filter assembly as follows:

“Micro-Mesh” Stainless Steel Filter Screen

- 1) **CAREFULLY** remove any debris from the screen using a scraper.
- 2) Remove the **STANDPIPE** and **KNURL** knob from the **FILTER SCREEN** assembly, grasp the **FINGER LOOP** on **FRAME A** and adjacent **FINGER LOOP** on **FRAME B**, **EVENLY** pull the frames apart; then **HINGE** FRAME A to remove it from the **FILTER SCREENS FIRST**.
- 3) Grasp the **FINGER LOOP** on the straight side of **FRAME B**; then **HINGE** it to remove **FRAME B** from the **FILTER SCREENS**.
- 4) Separate the **UPPER FILTER SCREEN** and **BAFFLE** from the **LOWER FILTER SCREEN**.
- 5) **CAREFULLY** clean the two frames, screens and baffle in the 3 compartment sink with hot water and allow these items to air dry. **DO NOT USE SOAP**. If necessary the channels in each frame can be cleaned with the edge of a scotch-brite pad.
- 6) Insert the **SUCTION FITTING** on the **BAFFLE** in the hole of the **UPPER FILTER SCREEN**; then place these items on top of the **LOWER FILTER SCREEN**.
- 7) **ENSURE** all sides of the **FILTER SCREEN** assembly are aligned, place the **PIN** end of **FRAME A** on the **FILTER SCREENS**, place the **CHANNEL** on the frame adjacent to the **PIN** end over the **FILTER SCREENS**; then **HINGE** the frame so the edge of the **FILTER SCREENS** are inserted in the other **CHANNEL** of **FRAME A**.
- 8) Place the **PIN** end of **FRAME B** on the **FILTER SCREENS** so the **PIN** is seated in the **CHANNEL** of **FRAME A** near the **FINGER LOOP**, place the **CHANNEL** on the frame adjacent to the **PIN** end over the edge of the **FILTER SCREENS**; then **HINGE** the frame so the edge of the **FILTER SCREENS** are inserted in the other **CHANNEL** of **FRAME B** and the **PIN** of **FRAME A** is seated in the **CHANNEL** of **FRAME B**.
- 9) Adjust **FRAME A** and **B** so both **PINS** are properly seated in the **CHANNEL** of the opposite frame; then **CAREFULLY** connect the **KNURL KNOB** and **STANDPIPE** to the **SUCTION FITTING** on the **FILTER SCREEN** assembly. **DO NOT OVERTIGHTEN!!!**

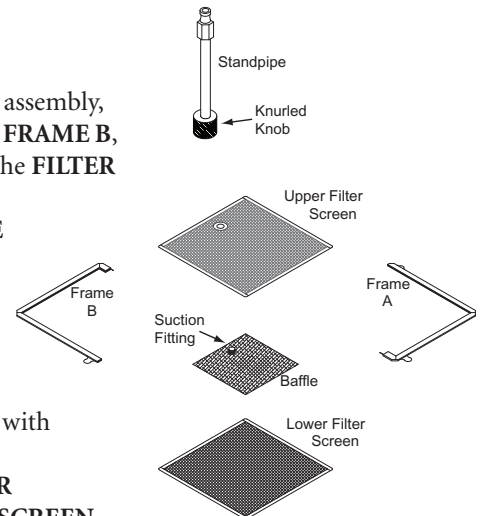

NOTE: “Magnepad Envelope” Filter: Magnepad Filter Assemblies **DO NOT** have to be **SCRAPED** after filtering shortening.

- d. Remove any sediment and shortening in the Filter Tub using a scraper; then wipe the tub dry with paper towels.
- e. Carefully insert the Filter Assembly in the bottom of the Filter Tub with the **STANDPIPE** centered in the handle end of the tub.

WARNING: WHEN ASSEMBLED, ENSURE THERE ARE NO FINGER LOOPS ON THE STANDPIPE SIDE OF THE FILTER.

- f. **SECURELY** connect the **FEMALE** fitting on the Suction Line Hose to the **MALE** stem on the Filter Screen **STANDPIPE**, install the assembled Filter Tub beneath the fryer until it is butted against the **STOP** bracket; then connect the **MALE** plug on the Suction Line Hose to the fryer's **FEMALE** Bulkhead Socket shown to the right.
2. If applicable, clean the Magnepad Envelope filter pad at **CLOSING** as follows:
 - a. Remove and discard the **USED** filter pad and **CAREFULLY** clean the Baffle and Clip/Standpipe assembly in a 3 compartment sink with **HOT** water and allow these items to air dry. **DO NOT USE SOAP!**
 - b. Reassemble the Magnepad envelope using a **NEW** filter pad as follows:
 - 1) Insert the **BAFFLE** into the **FILTER PAD ENVELOPE**, when inserted properly the **SUCTION FITTING** will protrude through the hole in the pad.
 - 2) Fold the **FLAP** over (towards the hole), secure the Baffle inside the **FILTER PAD ENVELOPE**.
 - 3) **CAREFULLY**, align the **CLIP & STANDPIPE** assembly so that the **CLIP** can secure the **FLAP** on the Envelope and the **STANDPIPE** will align over the **SUCTION FITTING** protruding through the Envelope.
 - 4) Tighten the krurled **NUT** on the **STANDPIPE** to the **SUCTION FITTING** protruding through the Envelope

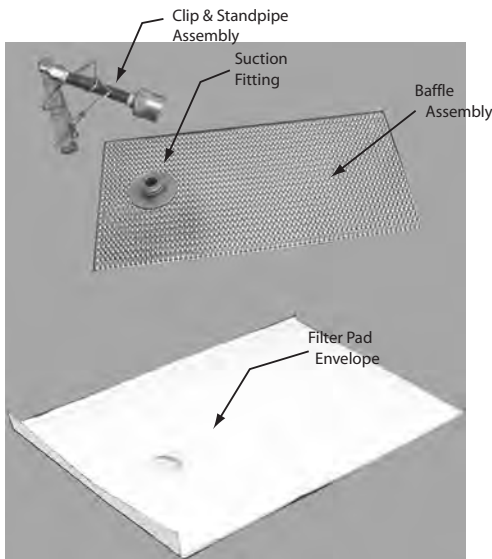
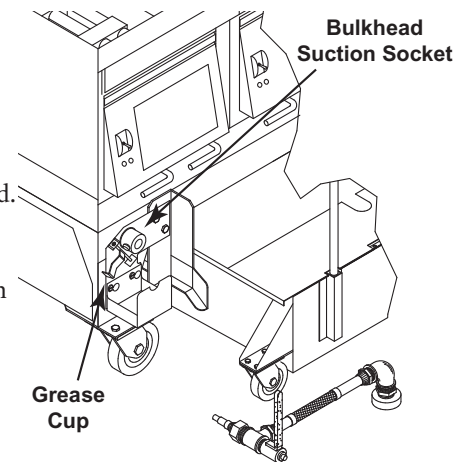

C. WEEKLY

1. Perform the daily cleaning steps B 1 a through B 1c. above.
2. Clean the Filter Assembly as follows:
 - a. "Micro-Mesh" stainless steel filter screen
 - 1) Disassemble the filter according to **DAILY** steps B. 1. c. 2) through B. 1. c. 4) and clean the two (2) frames as described in step B 1 c. 5).
 - 2) Place the upper and lower **FILTER SCREENS** in the fryer with **BOIL-OUT SOLUTION** for cleaning. **DO NOT PLACE THE BAFFLE OR STANDPIPE IN THIS SOULUTION!!!** **BOIL-OUT** the fryer vat accordng to instructions contained in the cleaning manual provided by your chemical supplier.

- 3) After the filter screens have been cleaned in the Boil-Out Solution, **ENSURE** they are **THOROUGHLY** sprayed with a solution of **1 PART** vinegar to **25 PARTS** of water to **NEUTRALIZE** the boil-out solution, then allow the screens to air dry. **NOTE:** any residue of boil-out solution on the filter screens could cause the rapid breakdown of the shortening.
 - 4) Reassemble the “Micro-Mesh stainless steel filter screen according to **DAILY** steps B 1. c. 6) through B 1. c. 9)
 - b. “Magnepad” Paper Envelope Filter
Disassemble, clean, and re-assemble the “Magnepad” Filter Assembly according to **DAILY** cleaning steps B 2) above.
3. **THOROUGHLY** clean the Filter Tub and Cover with **HOT SANITIZER SOLUTION** and allow them to air dry.
 4. Reassemble and install the Filter Tub according to **the FILTER TUB ASSEMBLY AND INSTALLATION section.**

WARNING: WHEN ASSEMBLED, ENSURE THERE ARE NO FINGER LOOPS ON THE STANDPIPE SIDE OF THE MICRO-MESH FILTER.

WARNING!! CRUMBS AND SLUDGE LEFT IN THE FILTER TUB OVERNIGHT ARE A FIRE HAZARD!!

FRYER OPERATION

A. GENERAL

The “basic” Gas Fryer is equipped with a Default-to-Manual-Restart (DTMR) Control, which uses an Electronic Thermostat. Some fryers are equipped with an Ultrastat 11,21 or 25 Cooking Computer that use the same Temperature Sensing Probe. In this section, the operation of the Gas Fryer will cover the Default-to-Manual-Restart (DTMR) Control.

NOTE: Refer to Manual PN 30A053, Ultrastat 11 Cooking Computer Operation Instructions; or 30A009, ULTRASTAT 21 Cooking Computer Operation Instructions; or Manual PN 30A051, ULTRASTAT 25 Cooking Computer Operation Instructions for operation of a fryer with one of these controls.

B. COOKING

Most products should be cooked with a shortening temperature about 350°F (177°C); however, each product should be cooked at the **LOWEST** temperature that produces a high quality product while obtaining maximum usage of the shortening.

DO USE A HIGH QUALITY SHORTENING TO ACHIEVE A CONSISTENT QUALITY PRODUCT AND LONG TERM SAVINGS.

DO NOT SALT PRODUCTS OVER THE FRYER AS SALT QUICKLY DETERIORATES THE SHORTENING AND FLAVORS OTHER PRODUCTS COOKED IN THE SAME SHORTENING.

DO FILTER SHORTENING AFTER THE LUNCH AND DINNER RUSH AND MORE OFTEN IN A HIGH SALE VOLUME STORE; AND BOIL-OUT THE FRYER EVERY SEVEN (7) DAYS.

WARNING: WHEN ASSEMBLED, ENSURE THERE ARE NO FINGER LOOPS ON THE STANDPIPE SIDE OF THE MICRO-MESH FILTER.

C. TEST START-UP AND COOKING

1. GENERAL

The Default-To-Manual-Restart(DTMR) Control along with an Electronic Thermostat is connected to a fryer’s electrical system to control operation of the fryer.

a. The DTMR contains a Default-To-Off circuit that will **DISABLE** the fryer anytime the Drain Valve is **OPEN**, and a Default-To-Melt circuit that will automatically place the fryer in a **SHORTENING MELT MODE** to gradually and safely heat shortening each time the fryer’s On/Off switch is turned **ON**.

b. Electronic Thermostat

The Electronic Thermostat has a temperature range from 200°F (93°C) to 400°F (204°C) and will accurately maintain a preset shortening cook temperature within ± 2°.

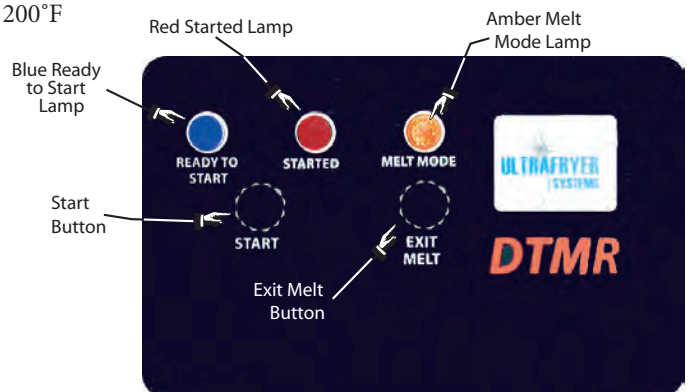

C. DTMR OPERATION

Prior to operating the Gas Fryer, **ENSURE** the Filter Tub Assembly is properly installed and **DOCKED** to the fryer’s Bulkhead socket and the Temperature Control Access Door is closed, the fryer vat is filled with shortening to the middle of the “E” in the word **LEVEL** of the shortening level mark on the rear wall of the vat; then:

1. Turn the On/Off Power Switch to the **OFF** Position.
2. Turn the **MANUAL** gas valve to the **OFF** position and wait **FIVE (5)** minutes for any accumulated gas to disperse.
3. **ENSURE** the **MAIN** gas shut-off valve is in the **ON** position, and that the **EXHAUST FAN** is **ON**.
4. Turn the **MANUAL** gas valve to the **ON** position.
5. Perform the following steps, in the order listed:



ITEM	ACTION	DTMR CONDITION
1	Ensure the drain valve is in the C losed (up) position and that the shortening is at the proper level, then turn the On/Off switch to the ON position.	A. Amber power lamp will ILLUMINATE . B. Blue Ready To Start lamp will ILLUMINATE .
CAUTION: PRIOR TO PROCEEDING TO STEP 2 , VISUALLY CHECK THAT THE HEAT ELEMENT IS COVERED WITH AT LEAST 2" (51mm) OF SHORTENING.		
2	Depress, then release the momentary Start button.	A. Red Started lamp and Amber Melt Mode lamp will ILLUMINATE . B. Blue Ready To Start lamp will turn off. C. The Melt Cycle Timing Module in the Default-To-Melt electrical circuit will begin cycling the fryer heat element ON for twelve (12) seconds and OFF for twenty-eight (28) seconds to safely heat the shortening.
CAUTION: PRIOR TO PROCEEDING TO STEP 3, VISUALLY CHECK THAT THE SHORTENING COMPLETELY COVERS THE HEAT ELEMENT.		
3	Depress, then release the momentary Exit Melt button.	A. Amber Melt Mode lamp will turn OFF , Red STARTED lamp will remain ILLUMINATED . B. The Melt Cycle Timing Module in the Default-To-Melt circuit will switch to the FULL ON position allowing the Electronic Thermostat to heat shortening to it’s pre-set temperature.
4	When the fryer’s pre-set temperature has been reached, initiate a cook cycle.	

FILTER TUB ASSEMBLY & INSTALLATION

A. GENERAL

The Par-3-18-TL Gas Fryer is equipped with a Filtration System, positioned under the fryer and located by guide rails, typically orientated beneath the left side of the fryer as shown below. The Fryer's On/Off switch, AMBER power and RED Burner Indicator Lamps are located on the Controller Access Door along with the Default-To-Manual-Restart (DTMR) controller. The filter pump On/Off switch and Amber pump indicating lamp are located above the access door near the CENTER vat and the TOPSIDE shortening return socket is located on the topcap as shown. The drain Lever for each vat is located beneath each access door and if applicable, the Shortening Evacuation System control lever is located adjacent the drain lever of the last vat.

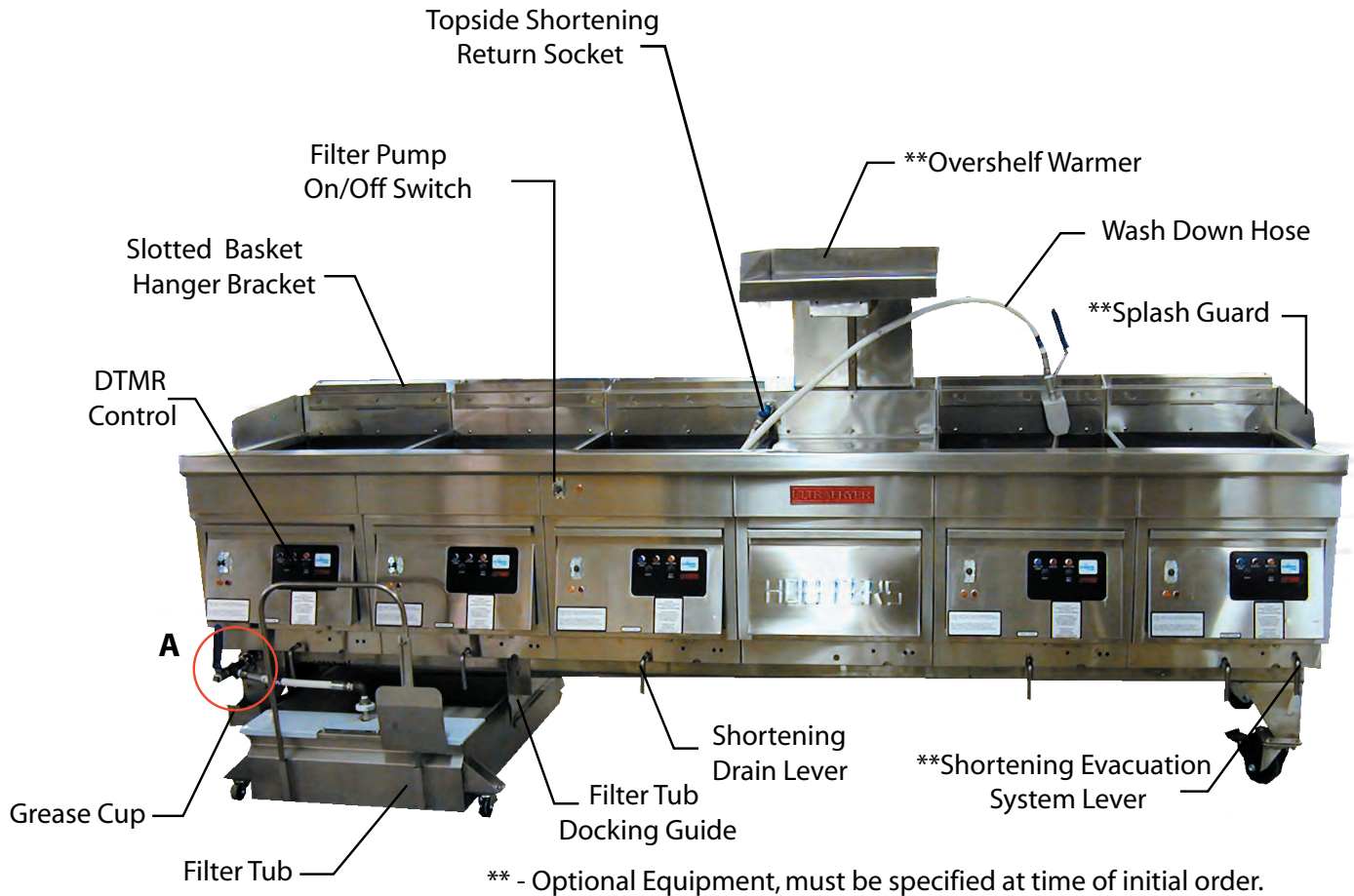

** - Optional Equipment, must be specified at time of initial order.

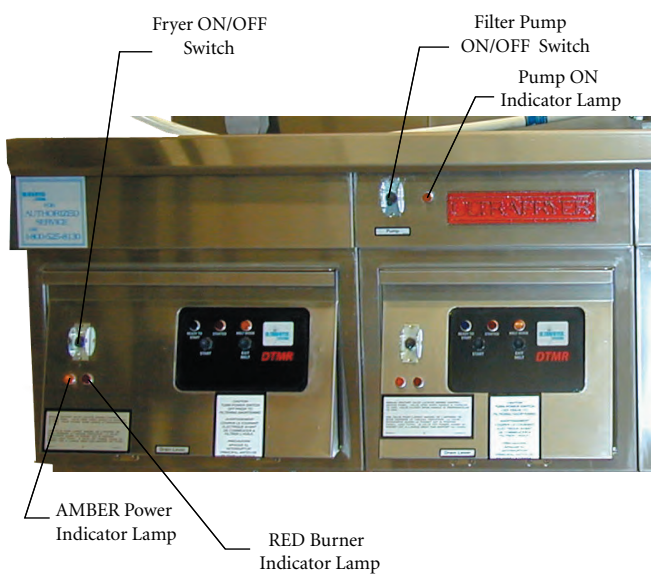

B. FILTER TUB ASSEMBLY

1. Make sure the FILTER TUB, HANDLE and COVER; SUCTION LINE HOSE, and FILTER ASSEMBLY are clean and dry.
2. Reassemble the Filter Tub by replacing the components in the following sequence:
 - a) FILTER ASSEMBLY
 - b) COVER
 - c) SUCTION LINE HOSE
 - d) FILTER TUB HANDLE.

CAUTION: WHEN ASSEMBLED, ENSURE THERE ARE NO FINGER LOOPS ON THE STANDPIPE SIDE OF THE MICRO-MESH FILTER.

C. FILTER TUB INSTALLATION

1. **CAREFULLY** insert the Filter Assembly in the bottom of the Filter Tub with the **STANDPIPE** centered in the handle end of the tub.
2. Place the cover on the Filter Tub; then install the Handle on the Filter Tub.
3. Install the Suction Line Hose **FEMALE** Quick-Connect fitting to the **MALE** Quick-Connect fitting to the plug on the filter screen **STANDPIPE**, insert the Filter Tub on the **FILTER TUB GUIDES** beneath the **LEFT** side of the fryer until it hits the **STOP** bracket; then connect the **MALE** plug on the Suction Line Hose Assembly to the Bulkhead Suction Socket on the Fryer.

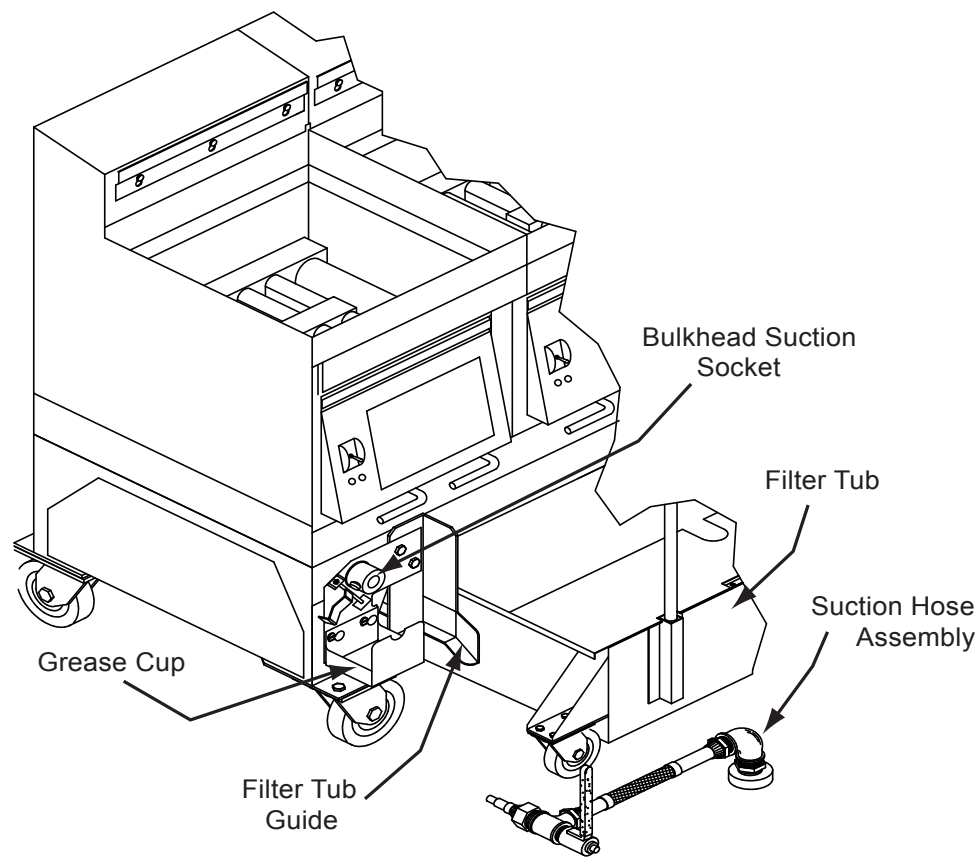

WARNING!! CRUMBS AND SLUDGE LEFT IN THE FILTER TUB OVERNIGHT ARE A FIRE HAZARD!!

FILTERING & POLISHING SHORTENING

A. GENERAL

Assemble the Filter Tub, connect the Suction Line Hose Assembly to the Filter Screen **STANDPIPE**, install the Filter Tub beneath the fryer; then connect the **MALE PLUG** on the Suction Line Hose to the fryer's **BULKHEAD** Coupling as described in the FILTER TUB ASSEMBLY AND INSTALLATION section.

B. FILTERING SHORTENING

1. Turn the On/Off Switch on the fryer vat to be filtered **OFF**, place the recommended amount of **FILTER AGENT** in the fryer vat; thoroughly stir the filter agent into the shortening using the skimmer, then skim the shortening to remove any floating crumbs.

CAUTION: PRIOR TO PROCEEDING TO THE NEXT STEP, PUT ON SAFETY GOGGLES, NEOPRENE INSULATED GLOVES AND AN APRON.

2. Carefully open the drain valve on the vat to be filtered by turning the **DRAIN LEVER** slightly downward. When the bottom of the filter tub is covered with about 2" (51 mm) of shortening, **OPEN** the drain valve and slowly drain shortening to allow the heat mechanism to gradually **COOL**.
3. When all shortening in the vat has drained into the filter tub, use the **DRAIN ROD** to stand the wire rack on one side of the vat.
4. Use the drain rod to break up the sediment caked on the bottom of the vat and to pull the sediment toward and into the drain valve opening.
5. Use a scraper to remove encrusted material from the sides of the vat and a stropping pad to remove carbon buildup from the top and sides of the heat mechanism.

WARNING : ENSURE THE FRYER'S POWER On/Off SWITCH IS IN THE "OFF" POSITION PRIOR TO PROCEEDING!

6. **SECURELY** connect the Wash Down Hose **MALE QUICK-CONNECT PLUG** to the topside **FEMALE QUICK-CONNECT SOCKET** on the upper panel of the **MIDDLE** fryer; then place the Wash Down Hose Holder Bracket into the slotted Bracket on the topcap of the vat so that the nozzle is between the Heat Exchanger and the side of the vat.

CAUTION: IF THE PLUG IS NOT SECURELY ATTACHED TO THE SOCKET, THERE WILL BE NO SHORTENING FLOW AND THE PUMP WILL OVER HEAT.

7. Turn the Pump On/Off Switch located just below the apron, to the **ON** position. The **AMBER** Pump Lamp will **LIGHT** and shortening in the filter tub will be discharged from the wash down nozzle into the fryer vat.
8. Remove the Wash Down Hose from the **HOLDER** and hold the Hose nozzle at a 45° angle from the bottom of the vat causing shortening and debris to bounce off the rear wall of the vat and flow towards the drain valve opening.
9. Use the "L" shaped vat brush to push the sediment through the drain valve to keep the drain clear. Hose off the burner tubes and all walls of the vat until all the shortening and residue at the bottom of the fryer has been flushed through the drain into the filter tub.

10. Turn the Pump On/Off Switch to the **OFF** position, the **AMBER** Pump Lamp will turn **OFF**. Place the Wash Down Hose Nozzle into the vat with its **HOLDER** seated in the slotted basket holder bracket on the topcap, and the nozzle is placed between the Heat Exchanger and the side of the vat.

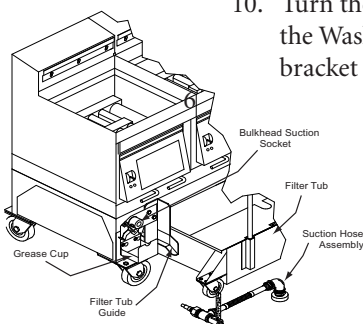

C. POLISHING SHORTENING

1. Turn the Pump On/Off Switch located just below the apron, to the **ON** position. The **AMBER** Pump Lamp will **LIGHT** and shortening in the filter tub will be discharged from the wash down nozzle into the fryer vat.
2. Set a timer for the amount of time established for POLISHING shortening and allow the shortening time to circulate through the system.

CAUTION: DO NOT POLISH THE SHORTENING MORE THAN THE ESTABLISHED TIME AS IT WILL AERATE THE SHORTENING CAUSING IT TO BREAKDOWN.

3. At the end of the established time, turn the PUMP On/Off switch to OFF the Amber pump indicator lamp will turn OFF. then remove the wash down hose.
4. Replace the wire grill in the fryer vat, turn the DRAIN LEVER to the CLOSED (UP) position then turn the pump On/Off switch ON to return shortening from the filter tub to the fryer.
5. When all shortening has been returned to the fryer, turn the pump On/Off switch OFF; check and if necessary, add fresh shortening to the vat until it is at it's proper level.
6. Repeat steps B1 thru B10 and C1 thru C5 to filter and polish shortening in the other fryer vats.
7. When the last vat has been FILTERED and POLISHED, remove the Wash Down hose from the TOPSIDE FEMALE QUICK-CONNECT socket and hang the hose in an UPRIGHT position to drain any residual shortening into a container.
8. Disconnect the suction line hose MALE QUICK-CONNECT PLUG from the FEMALE QUICK-CONNECT SOCKET, remove the filter tub from beneath the fryer by grasping it's handle and disconnect the suction line hose from the filter screen standpipe. Thoroughly clean and reinstall the filter tub and suction line hose assembly.

CAUTION: DO NOT USE THE STANDPIPE OR SUCTION LINE HOSE TO PULL THE FILTER TUB FROM BENEATH THE FRYER, TO DO SO WILL DAMAGE THE FILTER SCREEN.

9. Turn the fryer's On/Off switch to the **ON** position and resume normal operation.

SHORTENING DISPOSAL, BOIL-OUT & INSTALLATION

A SHORTENING DISPOSAL

Fryer vats should be **BOILED-OUT** at least every **7 DAYS** to remove carbon build up and other encrusted materials. Dispose of shortening as follows:

1. Assemble the filter Tub as described earlier, **SECURELY** connect the Suction Line Hose female quick-connect fitting to the Filter Screen **STANDPIPE**, insert the Filter Tub beneath the fryer; then **SECURELY** connect the **MALE** plug on the Suction Line Hose to the fryer's **BULKHEAD Suction Coupling**.
2. Turn the **FRYER'S On/Off SWITCH** and the **MANUAL GAS VALVE** to the first vat **OFF**.

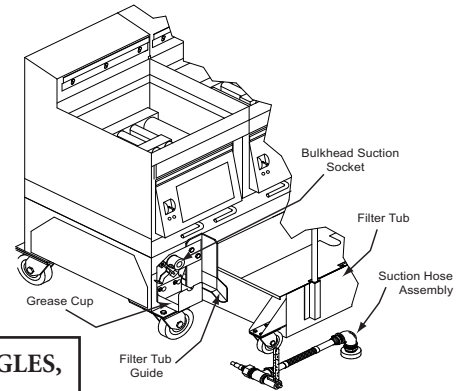

CAUTION: PRIOR TO PROCEEDING TO THE NEXT STEP, PUT ON SAFETY GOGGLES, NEOPRENE INSULATED GLOVES AND AN APRON.

3. Turn the venthood Exhaust Fan **ON** and drain shortening from the fryer vat as follows:
 - a. Carefully open the drain valve by turning the **DRAIN LEVER** slightly downward. When the bottom of the filter tub is covered with about 2" (51 mm) of shortening, **OPEN** the drain valve and slowly drain shortening to allow the heat mechanism to gradually **COOL**.
 - b. When all shortening has drained into the filter tub, use the **DRAIN ROD** to stand the wire rack on one side of the vat.
 - c. Use a scraper to remove encrusted material from the sides of the vat and a stropping pad to remove carbon buildup from the top and sides of the heat mechanism.

WARNING - ENSURE THE FRYER'S POWER On/Off SWITCH IS IN THE "OFF" POSITION PRIOR TO PROCEEDING!

- d. **SECURELY** connect the Wash Down Hose **MALE QUICK-CONNECT PLUG** to the **TOPSIDE FEMALE QUICK-CONNECT SOCKET** on the upper panel of the **MIDDLE** fryer; then place the Wash Down Hose Nozzle into the fryer vat with it's **HOLDER** seated on into the slotted Bracket on the rear wall of the vat so that the nozzle is pointed towards the left vat burner to direct hot shortening down into the vat.

CAUTION: IF THE PLUG IS NOT SECURELY ATTACHED TO THE SOCKET, THERE WILL NOT BE ANY SHORTENING FLOW AND THE PUMP WILL OVER HEAT.

- e. Turn the Pump On/Off Switch to the **ON** position. The **AMBER** Pump Lamp will **LIGHT** and shortening in the filter tub will be discharged from the Wash Down Hose Nozzle into the Fryer Vat.
 - f. Hold the hose nozzle at a 45° angle from the bottom of the fryer causing shortening and debris to bounce off the rear wall of the vat and flow towards the drain valve opening.
 - g. Use the "L" shaped vat brush to push the sediment through the valve to keep the drain clear. Hose off the burner tubes and walls of the vat until all the shortening and residue at the bottom of the fryer has been flushed through the drain into the filter tub.
 - h. When all debris and sediment has been flushed from the vat, turn the **PUMP** On/Off Switch to the **OFF** position. The **AMBER** Pump lamp will turn **OFF**.
4. Proceed as follows:

If the store is **not** equipped with a Shortening Disposal system, **PROCEED** to step 4. 1).

If the store **is** equipped with a Shortening Disposal system, **PROCEED** to step 4. 2).

If the store is equipped with a Shortening Disposal as well as a Shortening Evacuation system, **PROCEED** to step 4. 3).

 - 1) **Restaurants NOT equipped with a Shortening Disposal System**
 - a) Place the Wash Down Hose nozzle into a **METAL** container and hold it firmly against an inner wall. This prevents the hose from "jumping" when the Filter Pump is turned on.
 - b) Turn the **PUMP** On/Off switch to the **ON** position to pump shortening in the Filter Tub into the **METAL** container.
 - c) When all shortening in the filter tub has been pumped into the metal container, turn the **PUMP** On/Off switch to the **OFF** position.

- d) Repeat the steps in 4. 1) on the previous page to remove and dispose of shortening in the remaining fryers.
- e) When shortening has been removed from all fryers, remove the Wash Down Hose **MALE QUICK-CONNECT PLUG** from the **TOPSIDE FEMALE QUICK-CONNECT SOCKET** on the upper panel by **DEPRESSING** the **RELEASE** lever; then hang the hose in an upright position so shortening in the hose can drain into a container.

NOTE: Failure to hang the Wash Down Hose and Shortening Disposal Hose in an upright position may cause the hoses to become **CLOGGED** with hardened shortening.

2) **Restaurants EQUIPPED with a Shortening Disposal System**

- a) Remove the Wash Down Hose **MALE QUICK-CONNECT PLUG** from the **FEMALE QUICK-CONNECT SOCKET** on the upper panel of the middle vat, by **DEPRESSING** the **RELEASE** lever; then hang the hose in an upright position so shortening can drain into a container.
- b) **SECURELY** connect the **MALE QUICK-CONNECT PLUG** on the Shortening Disposal Hose to the **TOPSIDE FEMALE QUICK-CONNECT SOCKET** on the upper panel of the middle vat and connect the fitting on the other end of the hose to the Disposal System connector on the wall.
- c) Turn the **PUMP** On/Off switch to the **ON** position to pump shortening in the filter tub into the exterior rendering tank.
- d) Repeat the steps in 4. 2) above to remove and dispose of shortening in the remaining fryers..
- e) When shortening has been removed from all fryers, turn the **PUMP** On/Off Switch to the **OFF** position, remove the disposal hose **MALE PLUG** from the **TOPSIDE FEMALE SOCKET** by **DEPRESSING** the release lever; then hang the disposal hose in an upright position so shortening can drain into a container.

NOTE: Failure to hang the Wash Down Hose and Shortening Disposal Hose in an upright position may cause the hoses to become **CLOGGED** with hardened shortening.

3) **Restaurants EQUIPPED with a Shortening Disposal System and SHORTENING EVACUATION SYSTEM**
(Plumbing connected to the **EXTREME** right hand vat and exterior rendering tank)

- a) **CAREFULLY** disconnect the Wash Down Hose **MALE QUICK-CONNECT PLUG** from the **TOPSIDE FEMALE QUICK-CONNECT SOCKET** on the upper panel by **DEPRESSING** the **RELEASE LEVER**; then hang the hose in an upright position so shortening can drain into a container.
- b) **CAREFULLY** turn the **SHORTENING EVACUATION LEVER**, located on the **EXTREME** right hand vat, to the **OPEN** position (**CCW**); then turn the **PUMP** On/Off switch to the **ON** position.

CAUTION: DO NOT TURN THE PUMP SWITCH ON UNTIL THE SHORTENING EVACUATION LEVER IS IN THE OPEN POSITION!

- c) Shortening in the filter tub will be **AUTOMATICALLY** pumped into the exterior rendering tank.
- d) When all shortening has been pumped into the exterior rendering tank, turn the **DRAIN VALVE LEVER** for that vat to the **CLOSED (CW)** position and turn the drain valve lever to the next vat to the **OPEN (CCW)** position, then repeat the steps in 4. 3) above to pump the shortening out of the remaining vats to the exterior rendering tank.
- e) When shortening has been removed from **ALL** fryer vats, turn the **PUMP** On/Off Switch to the **OFF** position, then turn the **SHORTENING EVACUATION LEVER** to the **CLOSED (CW)** position.

5. When shortening has been removed from all Fryers, **THOROUGHLY** clean , assemble and install the filter tub according to the CLEANING and FILTER TUB ASSEMBLY AND INSTALLATION sections of this manual.

B FRYER BOIL-OUT

1. **BOIL-OUT** each fryer following cleaning instructions contained in the Cleaning Manual provided by your approved chemical supplier. The following are generic procedures:
 - a. Ensure all Drain Levers are in the closed (**UP**) position and the pump On/Off switch is **OFF**, then add water to each vat until it reaches a point two **2" (51 mm)** **BELOW** the middle line of the "**E**" in the word **LEVEL** of the **UPPER** shortening level mark on the rear wall of the vats.

WARNING: ONLY USE A COMMERCIAL "NON-CHLORINE" BOIL-OUT COMPOUND!!!

- b. Add the amount of **BOIL-OUT COMPOUND** in each fryer vat as prescribed in the Cleaning Manual provided by the Chemical Supplier.
- c. Turn the fryer's On/Off Switch and manual Gas Valve for the fryer to the **ON** position, depress and release the **START** button; then depress and release the **EXIT MELT** button on the DTMR.
- d. When the boil-out solution starts to **BOIL** set a timer for 30 minutes and frequently scrub the sides, front and back of the vat with a long handled scrub brush.
- e. While the fryer is being **BOILED OUT**, clean the filter tub assembly according to procedures in the cleaning section.
 - NOTE:** If the boil-out solution starts to boil over, shut the fryer **OFF** for a few minutes and add water as necessary, then turn it back **ON**.
- f. When the timer sounds, turn the fryer's On/Off Switch and Manual Gas Valve for the fryer to the **OFF** position; then **CAREFULLY** dispose of the boil-out solution in the fryer in a floor drain.

CAUTION: DO NOT USE THE PUMP/MOTOR UNIT TO REMOVE WATER FROM THE FRYER AS THIS WILL CAUSE PREMATURE PUMP FAILURE AND VOID THE WARRANTY.

- g. Use a scrubbing pad to remove carbon build-up from the top of the burner. To remove carbon build-up on the sides and bottom of the heat exchanger, slide one end of a stropping pad under each heat exchanger, grasp that end with a pair of tongs and rock the pad up and down along the length of each heat exchanger until all encrusted material has been removed. Replace the wire rack in the fryer.
- h. Rinse the fryer with hot water until the water coming out of the drain valve is clear.
- i. Mix a solution of **ONE PART** vinegar to **25 PARTS** of water. Place this mixture into a one-gallon garden pressure sprayer and **THOROUGHLY** spray this solution onto the **SIDES, BURNER TUBES** and **BOTTOM** of the fryer to neutralize the Boil-Out Compound.

NOTE: Boil-Out Compound will cause shortening to break down rapidly if it is not neutralized.

- j. **THOROUGHLY** wipe the sides, burner tubes and bottom of the fryer with clean, lint-free, dry towels to remove any remaining water, turn the **DRAIN VALVE** to the closed **UP** position; then fill the fryer with **NEW** shortening to the applicable shortening level mark according to the procedures below.

C. SHORTENING INSTALLATION

1. LIQUID SHORTENING

When using liquid shortening fill the fryer with cool shortening $\frac{1}{2}$ " (13mm) **BELOW** the "**E**" in the word **LEVEL**. When heated ensure shortening is even with the "**E**" in the word **LEVEL**.

2. SOLID SHORTENING

- a. Cut a block of solid shortening into small pieces.
- b. Place small pieces of solid shortening **EVENLY** on top of the **HEAT EXCHANGER TUBES** or **THOROUGHLY PACK** these pieces of solid shortening between, below and above the **HEAT EXCHANGER TUBES**. While packing solid shortening is messy and time consuming, it is the fastest way to melt solid shortening.
- c. Turn the fryer On/Off switch to the **ON** position; then place the **DTMR** or other fryer control in the **MELT MODE**.
- d. When the **BURNER TUBES** are completely covered with **LIQUID** shortening, replace the grill in the fryer vat; then place the fryer in the **FULL ON** mode.
- e. Continue adding solid shortening as follows:
 - 1) Place small pieces of solid shortening into a fry basket.
 - 2) **CAREFULLY** lower the basket into the fryer vat.
 - 3) **GENTLY** turn the basket to allow these pieces of solid shortening to float away.
 - 4) Repeat the above steps until liquid shortening is even with the middle line of the "**E**" in the word **LEVEL** of the applicable shortening level mark on the rear wall of the fryer vat.

WARNING!!! TO AVOID INJURY

- I DO NOT MOVE A FRYER FILLED WITH HOT LIQUID.
- II THE FRYER MUST BE RESTRAINED BY USE OF A RETAINING DEVICE TO PREVENT TIPPING TO AVOID THE SPLASHING OF HOT LIQUID.
- III THE AREA SURROUNDING THE FRYER MUST BE KEPT FREE AND CLEAR OF ALL COMBUSTIBLES.
- IV DO NOT GO NEAR THE AREA DIRECTLY OVER THE FLUE OUTLET WHEN THE FRYER'S MAIN BURNERS ARE OPERATING.
- V ALWAYS WEAR OIL-PROOF, INSULATED GLOVES WHEN WORKING WITH A FRYER FILLED WITH HOT OIL.
- VI ALWAYS DRAIN HOT OIL INTO A METAL TUB, POT OR CAN ... HOT OIL CAN MELT PLASTIC BUCKETS OR SHATTER GLASS CONTAINERS.

TECHNICAL ASSISTANCE & ORDERING INFORMATION

A. TECHNICAL ASSISTANCE

Contact an authorized service agent or the Customer Service Department, Ultrafryer Systems at 1-800-525-8130 for technical assistance.

B. ORDERING INFORMATION

1. REPLACEMENT PARTS

Provide the following information when ordering replacement parts by phone, fax or mail:

Your company name and phone number

Your company purchase order number

Bill-to address

Ship-to address

Quantity desired

Part number and description of the desired-item

Your name or signature of authorized-buyer

Phone in order to: 1-800-545-9189 Ext 5029

FAX order to: 1-210-731-5099

Mail order to: Ultrafryer Systems
Order Entry Office
P.O. Box 5369
San Antonio, TX 78201

E-Mail your order to: Ultrafryerservice@ultrafryer.com

2. TERMS

Net 30 days for customers on approved accounts. Past due balances will be charged 1% per month (12% per annum) until full balance is paid.

3. DAMAGES

Ultrafryer Systems is not responsible for damage occurring in transit. All deliveries must be inspected for damage to shipping containers prior to departure of the delivering carrier. Any damage must be notated on the receiving document to facilitate filing of freight claims. Carriers must be notified immediately and freight inspections must be requested from the carrier. Ultrafryer Systems can and will gladly assist you in preparing and processing of the necessary claims only if proper notification has been accomplished on the carrier delivery document. Damaged equipment and or containers must be available for the claims inspector to inspect.

4. RETURNS

Ultrafryer Systems cannot guarantee credit for items returned without proper authorization. All returns must have prior Ultrafryer Systems Customer Service or Warranty department approval. An assigned number will be issued by the approval authority. Please print the assigned number on all returned packages and corresponding paperwork. Returned goods are subject to a 15% restocking charge. Ultrafryer Systems is not responsible for freight charges on returned goods unless authorized by Customer Service and or Warranty personnel. Ultrafryer Systems does not receive freight collect or C.O.D. shipments.

RECOMMENDED SPARE PARTS

RECOMMENDED SPARE PARTS

To minimize downtime on the fryer upon failure of a component part, at least one (1) of the following items should be kept as a spare part in the local area:

GAS FRYER RECOMMENDED SPARE PARTS LISTING	
<u>Description</u>	<u>PN</u>
Ignitor Spark Module	18179
24 Volt Stepdown Transformer	18180
24 Volt Combination Gas Control Valve	18227
SPDT On/Off Switch	18A287
Air Pressure Switch	18A291
Hi-Limit Switch	19A144
½" (13mm) Apollo Pump Control Valve	24036
¼" (5mm) Compression Fitting	24247
½" (13mm) Manual Gas Valve	24326

PARTS IDENTIFICATION

PARTS IDENTIFICATION

Locate the part on the following sketches and note the index number i.e, 3, 6, etc; then obtain the part number and description for that index number on the page facing the sketches. Use that part number when ordering a replacement part.

MODEL PAR-3-18-TL GAS FRYER

FIGURE 1

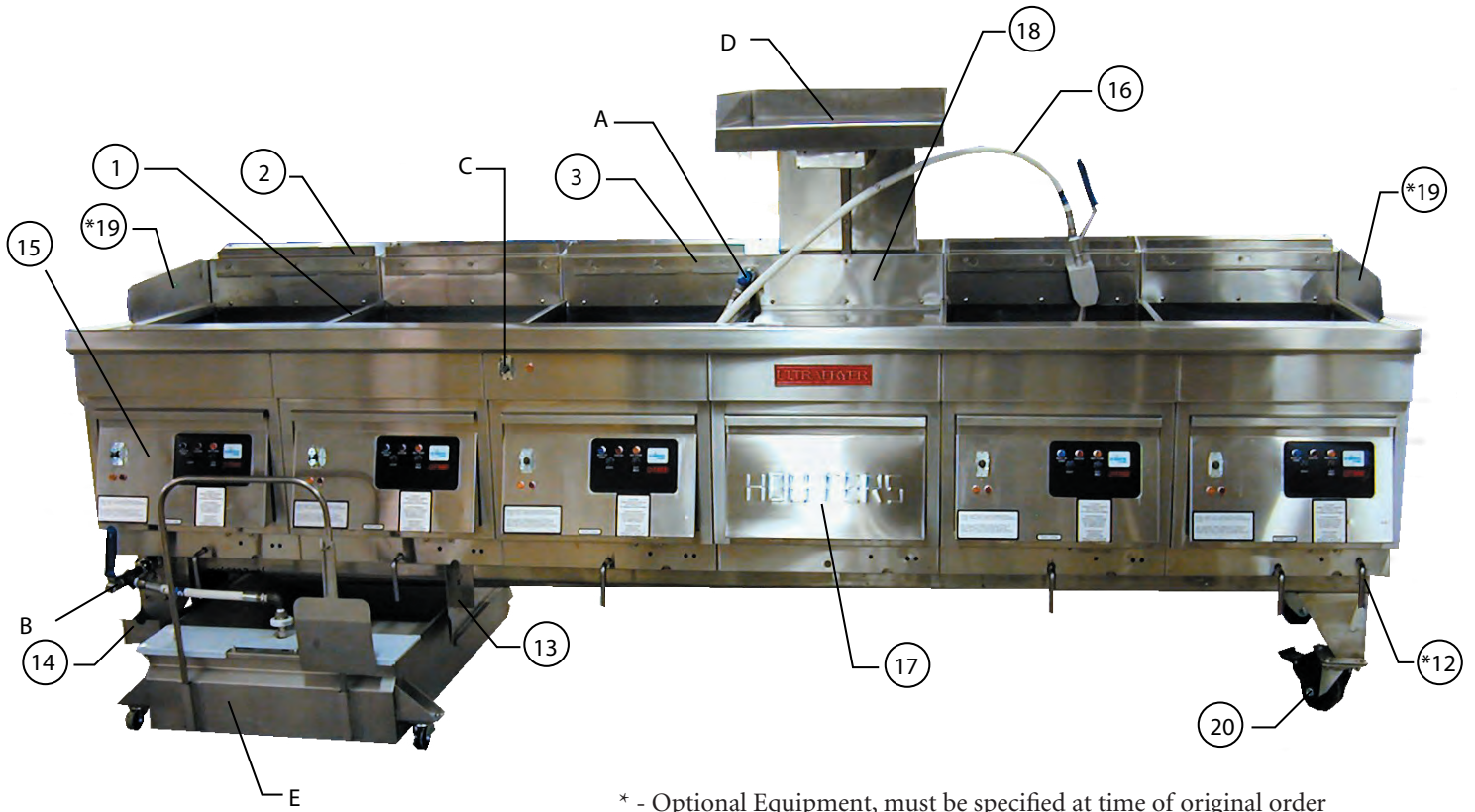

* - Optional Equipment, must be specified at time of original order

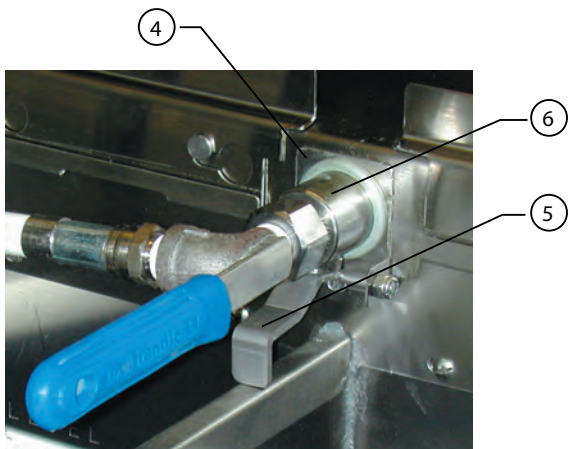

FIGURE A

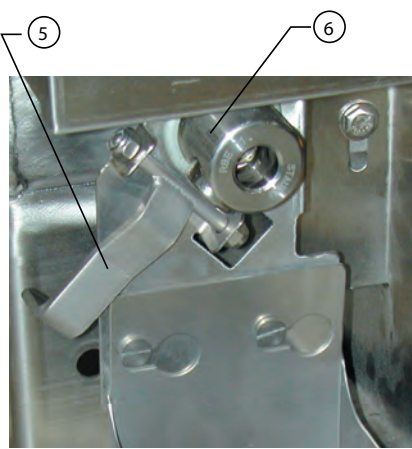

FIGURE B

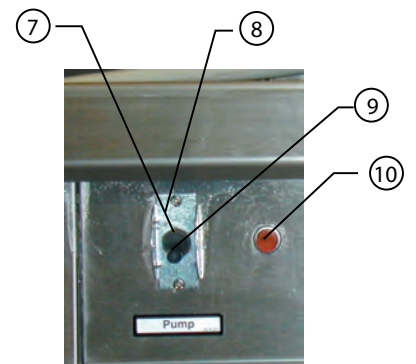

FIGURE C

FIGURE 1

	ITEM	DESCRIPTION	PN
	1	18" Joiner Strip	19A503
	2	18" Basket Hanger Bracket W/ Wash Down Hose Slot	19B345
	3	18" Double Topcap Basket Hanger Bracket W/ Wash Down Hose Slot	19B346
	4	Bracket, Button Release Handle Topcap	19A940
	5	Handle, Button Release Short	19A954
	6	Coupling, 11mm Bulkhead Shutoff Female In-Line	24A209
	7	125/250 Volt 15/10 Amp SPST Pump/Motor On/Off Switch	18204
	8	On/Off Switch Guard	18129
	9	Switch Protective Boot	23402
	10	125 Volt 1/3 Watt Pump Snaplight W/AMBER Lens	23A056
*	11	2" (51mm) Drain Valve Lever	12A477
	12	Optional Shortening Evacuation System Drain Handle	19B550
	13	Filter Tub Docking Guides	12B461
	14	Grease Cup	12B116
	15	18" Door Assembly F/DTMR	12A943
	16	72" Wash Down Hose Assembly	12B161
	17	18" Angled Work Station F/ Hooters	19A098
	18	18" Large Bank Work Station W Hatco Warmer	NOTE 1
	19	Optional 18" RH Splash Guard RH LH	12810 12870
	20	Medium Duty 4" (102mm) Front Caster W/ Brake	28015
*	21	Drain Clean Out Rod	12569
*	22	"L" Shaped Cleaning Brush	29A044
*	23	Vat Grill 18" (Order Deflector Clip PN 19B177 When Ordering This Item)	22704

* NOT SHOWN

NOTE 1 - Item requires special order. Contact UFS Customer Service for details.

MODEL PAR-3-18-TL GAS FRYER
FRONT VIEW

FIGURE 2

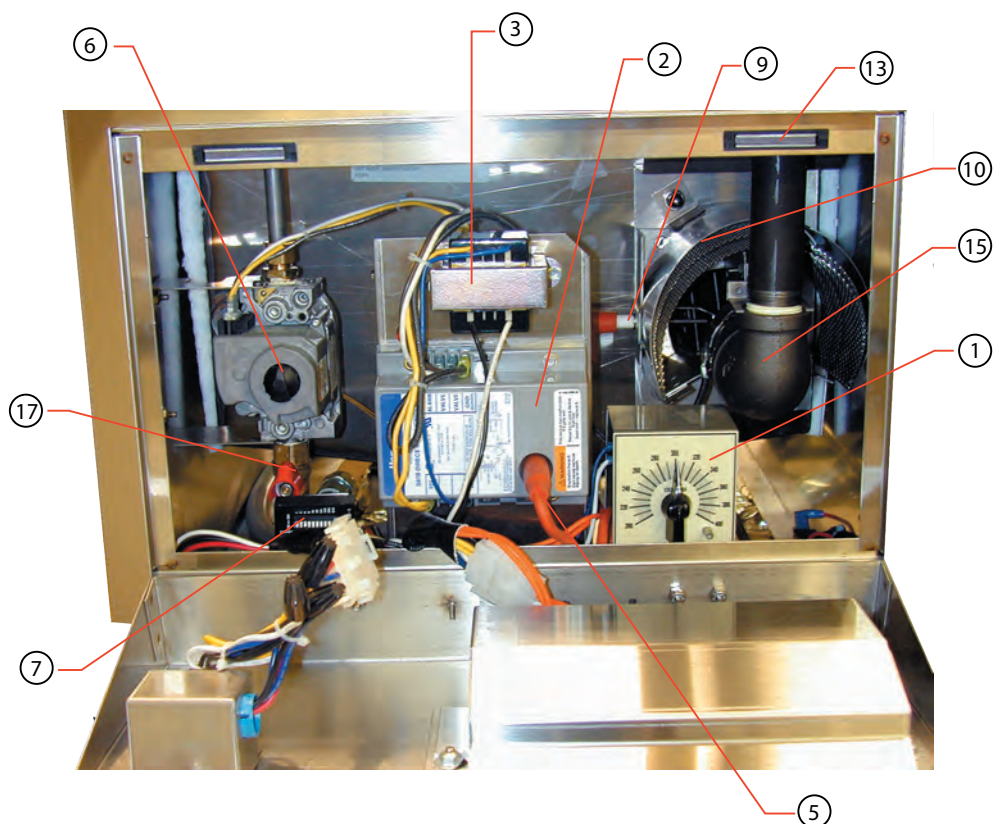

ITEM	DESCRIPTION	PN
1	Electronic Thermostat (Used with Default-to-Manual-Restart (DTMR) Control PN 12B013)	12B077
2	Spark Ignitor Module	18179
3	120 Volt to 24 Volt Step-Down Transformer	18180
*	Drain Valve Lever Microswitch	18185
5	Ignitor Rod Cable w/plugs	18187
6	Electric Gas Combination Control Valve (Uses mounting bracket 19A113)	18227
7	Delay on Make Relay (NOTE: Set Relay to "4" prior to installation.)	18A045
*	Electronic Thermostat Temperature Probe	18A276
9	Ignitor Spark Rod Bracket with Ignitor Rod (Set Rod Gap to 5/32" (4mm) prior to installation.)	19A738
10	Sound Weldment Baffle	19A739
*	Hi-Limit Switch Pre-Set to trip at 400° F (204°C) (Order a ¼" (5mm) Compression Fitting PN 24247 when ordering this item.)	19A144
*	Agitator Weldment Baffle	19A500
13	Magnetic Door Catch	22407
*	½" (13mm) FIP x ½" (13mm) MPT Flexible Gas Line 36"(914mm) Long	24A011
15	Ferrofix Nozzle Eclipse Burner	22A112
*	Cast Iron Venturi	22A118
17	½" (13mm) ID Manual Gas Valve W/RED Handle	24326
*	"NATURAL GAS" Orifice Plug W/ #10 Drill Hole (For Orifice Plug Holder Order PN 24A105)	24A070

* NOT SHOWN

NOTE: For BUTANE GAS Orifice with #36 Drill Hole, order PN 24A067 and for PROPANE GAS Orifice with #32 Drill Hole, order PN 24A066.

THIS PAGE INTENTIONALLY BLANK

MODEL PAR-3-18-TL GAS FRYER
REAR VIEW

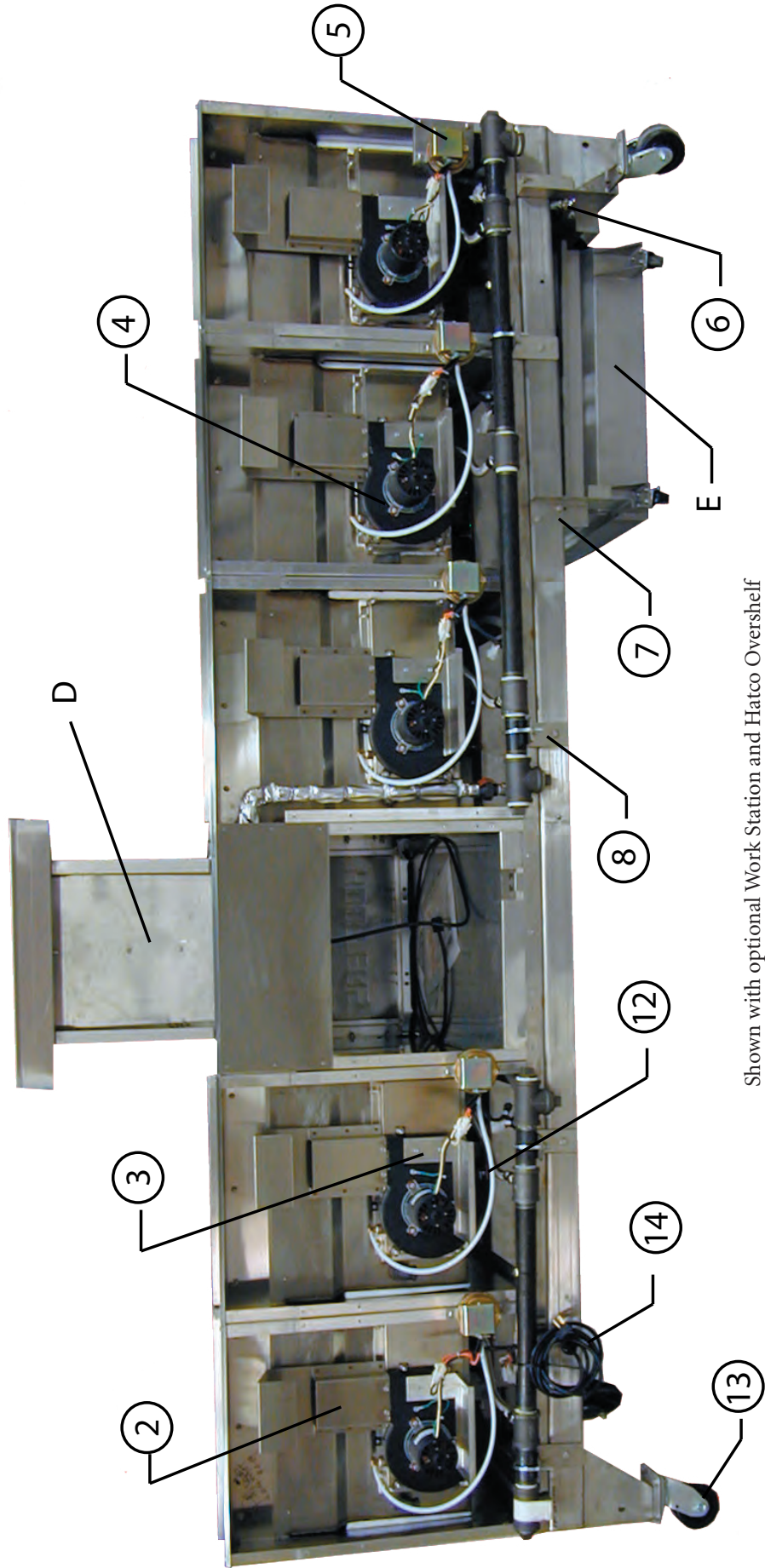

Shown with optional Work Station and Hatco Overshelf

	<u>ITEM</u>	<u>DESCRIPTION</u>	<u>PN</u>
*	1	2" Drain Ball Valve Assembly (Order Gasket PN 22A119 When Ordering This Item)	12775
	2	PAR-3-18 Rectagular Flue Tub w/ Deflector	19A473
	3	Blower Motor Drip Pan	19A527
	4	115 V 60 Hz Exhaust Blower Motor Kit w/ Mounting Bracket (Order Gasket PN 19A546)	19A548
	5	Air Pressure Switch	18A291
	6	7.7 GPM (29.26lpm) Pump/Motor Assembly	24A207
		Replacement Pump	24329
		Replacement Motor	17A018
	7	Filter Tub Docking Guide (Set)	12B461
	8	Gas Manifold Mounting Bracket	19A214
*	9	125 V 75 Watt Silicon Heater 5' (1524mm) Long	23341
*	10	½" (13mm) Pump Ball Valve	24036
*	11	½" (13mm) MPT x ½" (13mm) MPT Flexible Gas Line 36" (914mm) Long	24A011
	12	3/16" (5mm) ID, 5/16" (8mm) OD Plastic Tube Rated For 500°F (260°C)	24A068
	13	Medium Duty 4" (102mm) Rear Caster W/O Brake	28016
	14	Type SJO 16/3 Electrical Cord w/ 90° Molded Plug	33048

* - Not Shown

FIGURE D

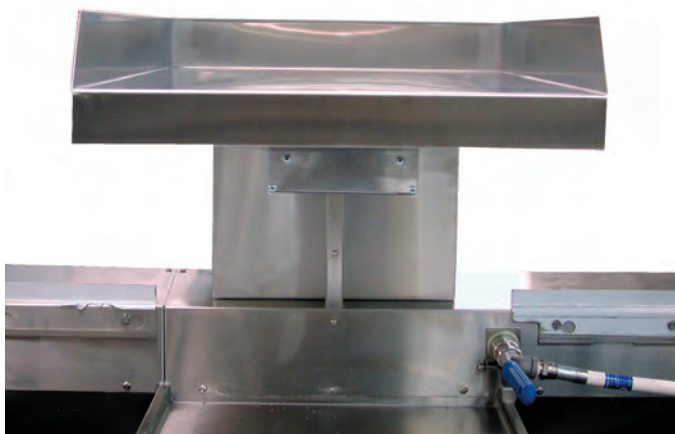

	<u>ITEM</u>	<u>DESCRIPTION</u>	<u>PN</u>
*	1	Hacto Overshelf Warmer	12B503

FILTER TUB ASSEMBLY
11B400

FIGURE E



	<u>ITEM</u>	<u>DESCRIPTION</u>	<u>PN</u>
*	1	Filter tub Scraper	12567
	2	Micro-Mesh S/S Filter and Standpipe Assembly	12A807
*	3	Magnepad Filter and Standpipe Assembly (Note)	12A813
	4	Filter Tub Cover	19B369
	5	Filter Tub Tank	19B354
	6	Filter Tub Handle	19B526
	7	1 ¼" (32 mm) Black Iron Pipe Cap	24A152
	8	Medium Duty Caster	28A005
*	9	1 ¼" (32 mm) Boil-out Drain Ball Valve (Optional)	24A069

* Item not shown

Note: Magnepad Assembly PN 12A813 can be provided with
Filter Tub Assembly in lieu of Micro-Mesh Filter PN 12A807.

SUCTION LINE HOSE ASSEMBLY
PN12B122

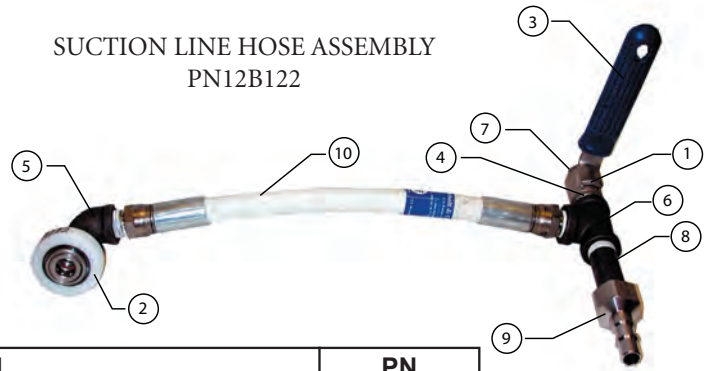

ITEM	DESCRIPTION	PN
1	Suction Line Hose Handle Assembly	19A932
2	Female Quick-Connect Fitting	22677
3	Cool Handle II Grip	22734
4	1/2" (13 mm) X Closed Black Iron Nipple	24003
5	1/2" (13 mm) x 90° Black Iron Street Elbow	24256
6	1/2" x 1/2" x 1/2" (13 x 13 x 13 mm) Black Iron Tee	24A083
7	1/2" (13 mm) Black Iron Square Head Plug	24A084
8	1/2" (13 mm) x 3" Black Iron Nipple	24039
9	1/2" (13 mm) FPT x 2 7/8" (73 mm) Long S/S In-Line Male Plug	24A208
10	NSF APPROVED 1/2" (13 mm) x 15 1/2" (381 mm) Long, Food Grade wire reinforced Hose w/Fittings	24A229

TEMPERATURE CONTROL ACCESS PANELS

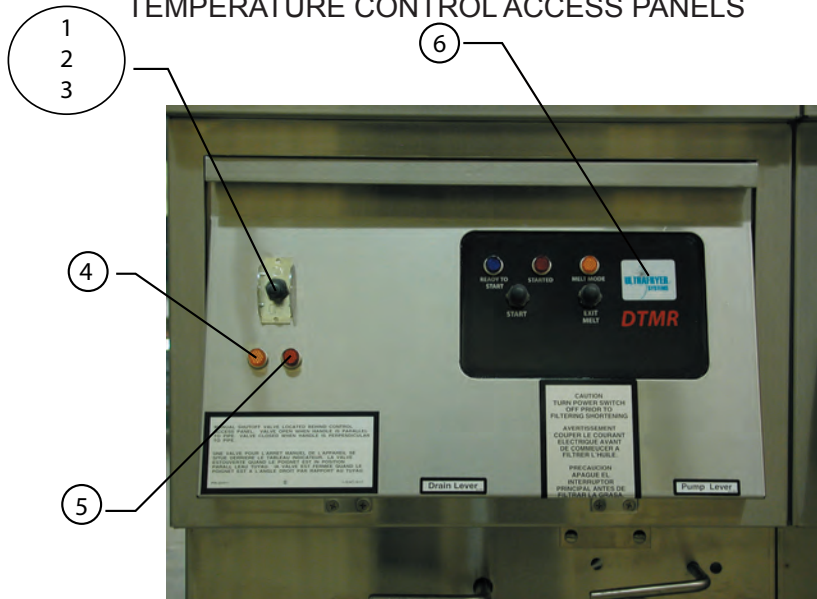

ITEM	DESCRIPTION	PN
1	On/Off Switch Guard.	18129
2	120 Volt 6 Amp SPDT On/Off Switch.	18A287
3	On/Off Switch Protective Boot.	23402
4	125 Volt 1/3 Watt Snaplight w/ AMBER Lens.	23A056
5	125 Volt 1/3 Watt Snaplight w/ RED Lens.	23362
6	COOKING CONTROL Default-To-Manual-Restart (DTMR) Control. Uses Electronic Thermostat PN12B077.	12B013

ELECTRONIC THERMOSTAT
PN 12B077

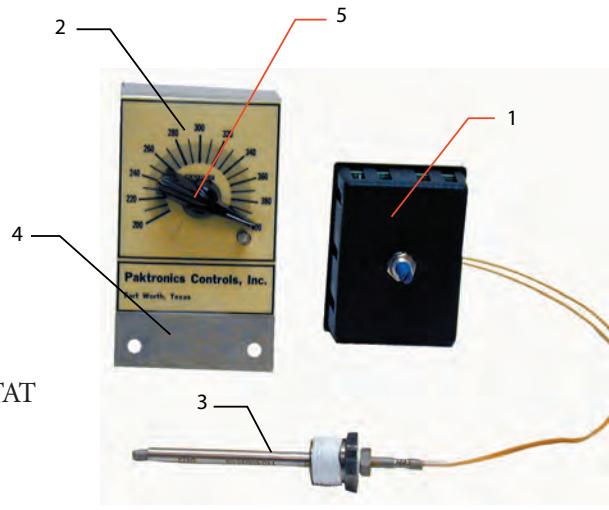

ITEM	DESCRIPTION	PN
1	Electronic P14 Thermostat	18A058
2	Electronic Thermostat Face Plate	18A070
3	Temperature Probe	18A276
4	Electronic P14 Thermostat Bracket	19B174
5	Electronic Thermostat Knob	22A169

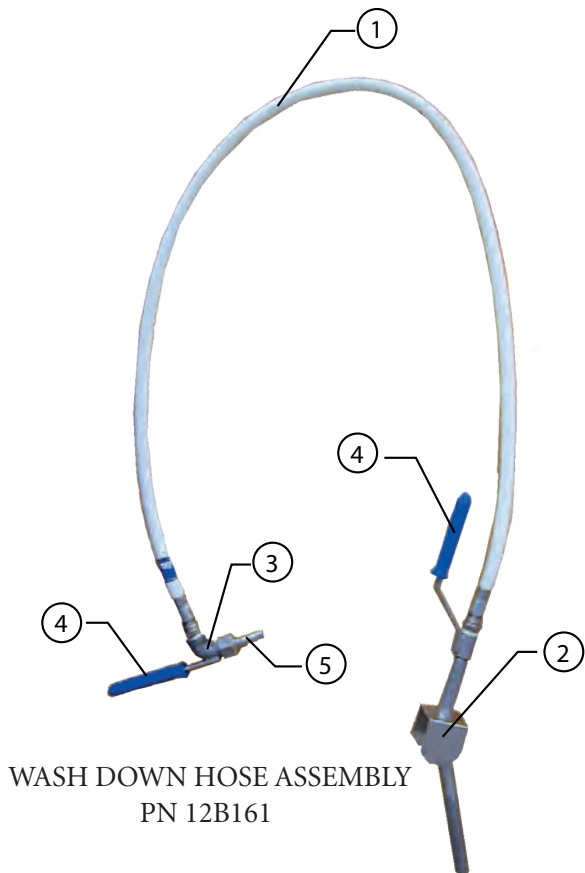

WASH DOWN HOSE ASSEMBLY
PN 12B161

ITEM	DESCRIPTION	PN
1	6 ft (1829mm) Wash Down Hose w/Fittings	12541
2	Wash Down Handle & Nozzle with Holder	MOD12675
3	90° Black Iron Street Elbow	19A958
4	Cool II Handle	22734
5	½" (13mm) FPT X 2 7/8" (73mm) long S/S in-line male plug	24A208

MICRO MESH FILTER SCREEN
& STANDPIPE ASSEMBLY
PN 12A807

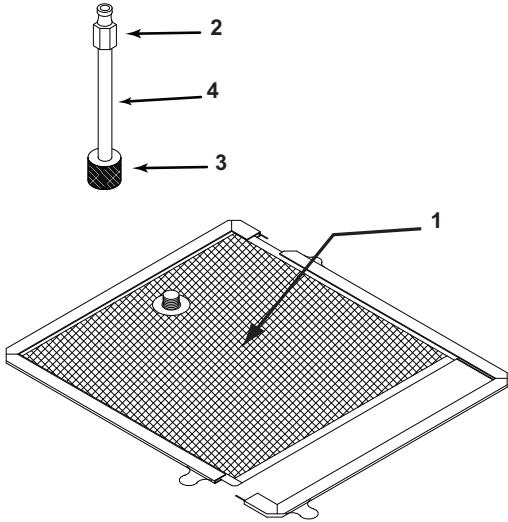

ITEM	DESCRIPTION	PN
1	Micro Mesh Filter Screen (see exploded view)	21A279
2	3/8" (10 mm) NPT Male Stem Quick Connect Fitting	22676
3	Top Compression Cap (Knurl Knob)	24369
4	3/8" (10 mm) x 7" (178 mm) S/S Nipple	24471

EXPLODED
VIEW

ITEM	DESCRIPTION	PN
1	Filter Screen Frame Set	21A275
2	Upper Filter Screen	21A281
3	Baffle w/suction line fitting	21A282
4	Lower Filter Screen	21A274

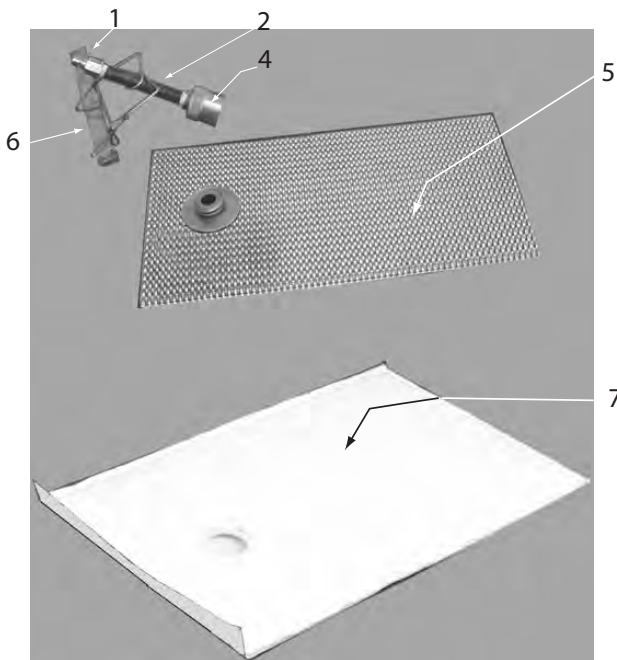
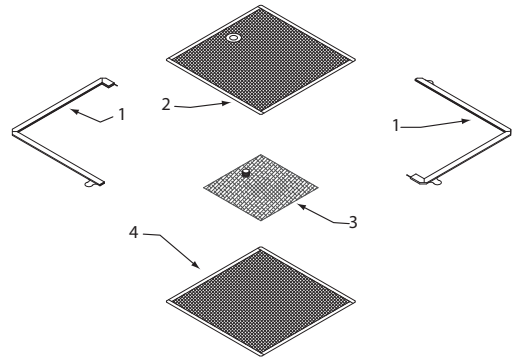

MAGNEPAD MAGNESOL FILTER & STANDPIPE ASSEMBLY
PN 12A813

ITEM	DESCRIPTION	PN
1	3/8" (10mm) NPT Quick-Connect Male Stem Fitting	22676
2	3/8" x 7" (10mm x 178mm) S/S Nipple	24471
3	23" x 30 1/2" (597 x 775mm) Baffle Kit consisting of items 4, 5, & 6.	29A055
4	Top Compression cap (Knurl Knob)	24A153
5	21 1/2" x 29" (456 x 737mm) Baffle	29A049
6	23" (584mm) Long Standpipe Clip	29A051
7	23 1/2" (597mm) x 30" (762mm) Filter Pad	29A047
*8	Case of 30 Filter Pads	29A053

* Not Shown

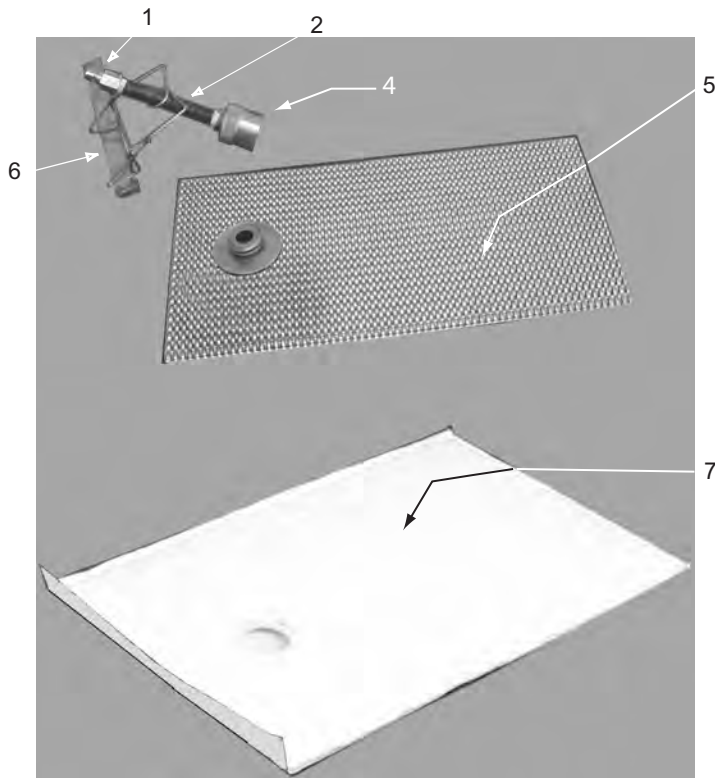

MAGNEPAD PAPER FILTER & STANDPIPE
ASSEMBLY
PN 12B554

<u>ITEM</u>	<u>DESCRIPTION</u>	<u>PN</u>
1	3/8" (10mm) NPT Quick-Connect Male Stem	22676
2	3/8" (10mm) x 7" (178mm) S/S Nipple	24471
3	23 1/2" (597mm) x 30 1/2" (775mm) Baffle Kit (consisting of items 4,5, & 6)	29A055
4	Top Compression Cap (Knurl Knob)	24A153
5	21 1/2" (546mm) x 29" (737mm) Baffle	29A049
6	23 1/2" (597mm) Standpipe Clip	29A051
7	23 1/2" (597mm) x 30 1/2" (775mm) Filter Pad	29A071
*8	Case of 30 Filter Pads	29A073

* NOT SHOWN

WIRING DIAGRAM

WIRING DIAGRAM

Since minor wiring changes may occur in the future, **USE** the diagram pasted to the fryer for trouble-shooting a fryer.

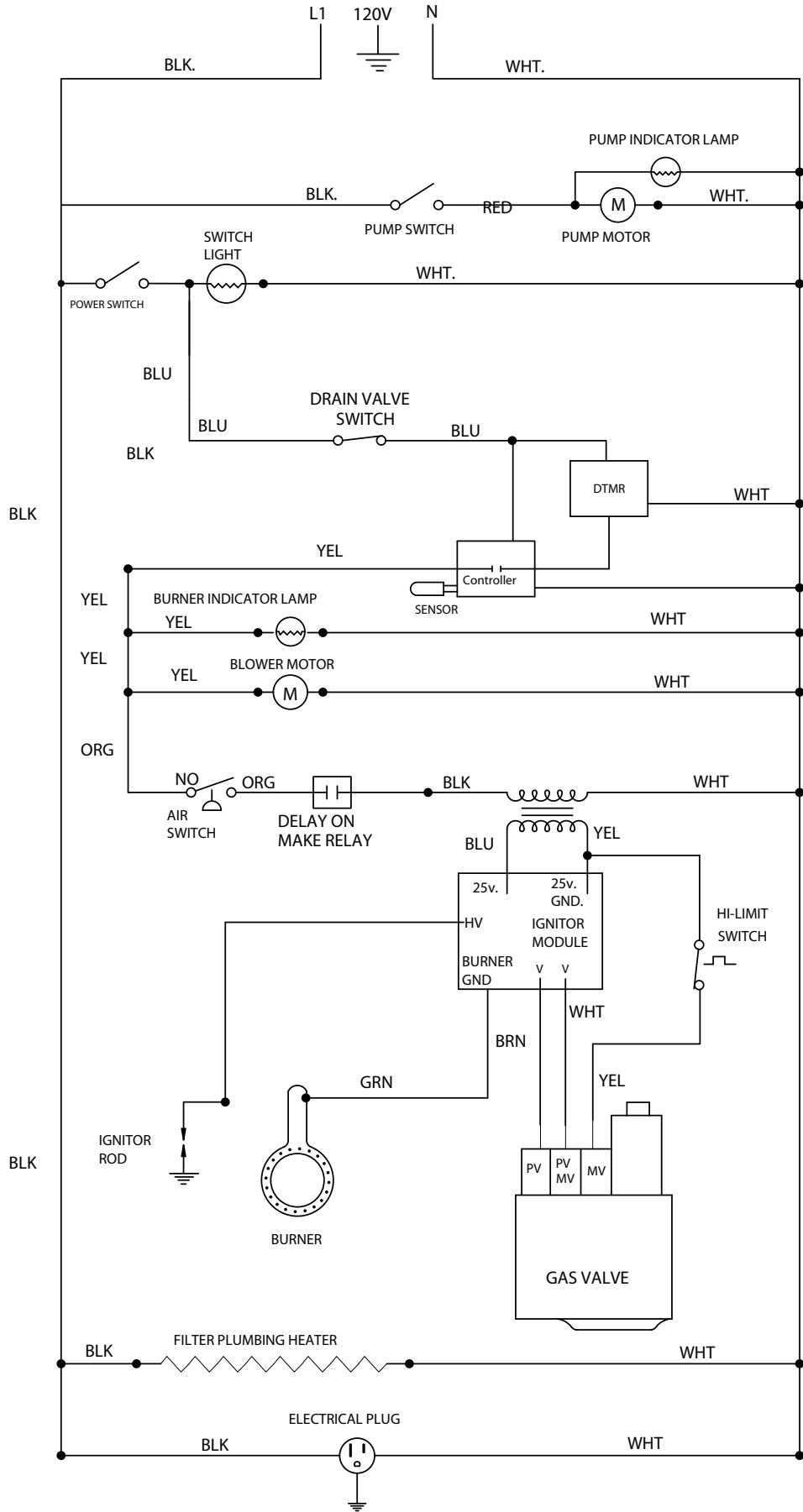

NOTE: PUMP SWITCH ON CENTER VAT ONLY

THIS PAGE INTENTIONALLY BLANK